

Manual : N° 7386

INSTALLATION

Totem operator

Sliding gate

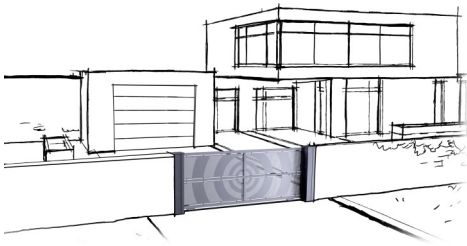

On existing or aluminum posts

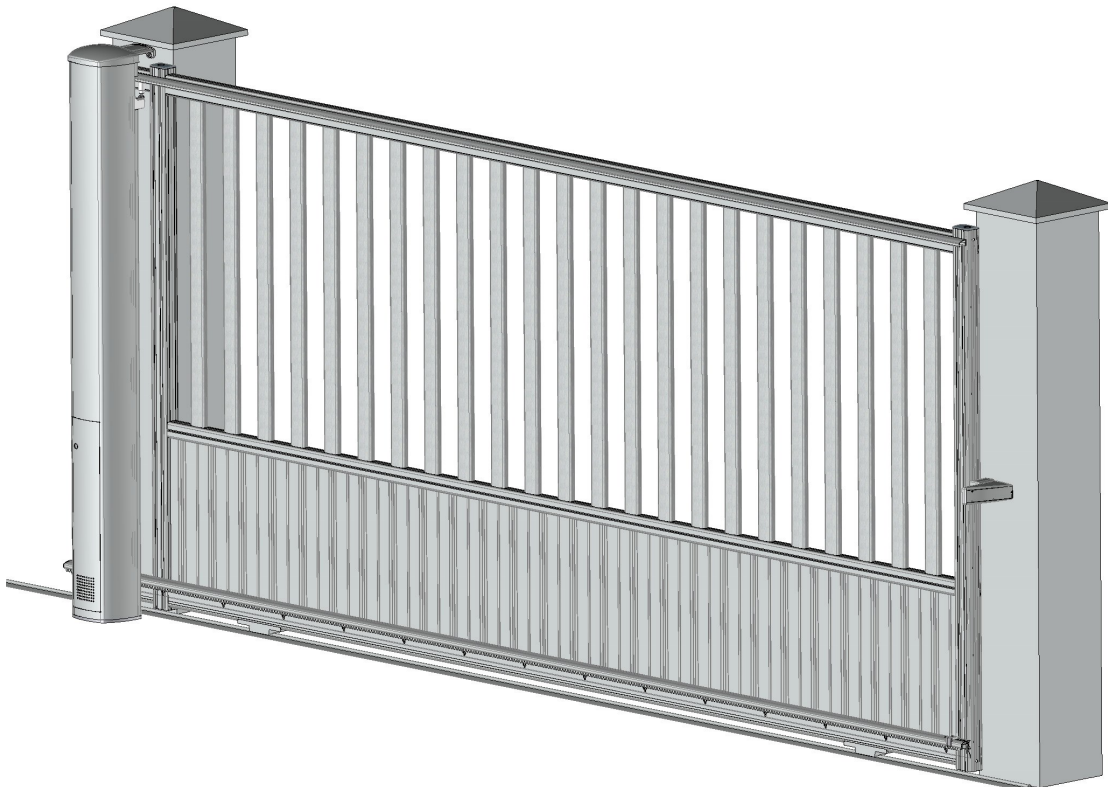

(Document reserved for installers)

Contents

Required equipment.....	p.2
Installation instructions.....	p.3
Electrical duct installation.....	p.4
Assembling + installing the aluminum posts (Option).....	p.4
Check of existing posts.....	p.5 to p.6
Guide rail attachment (on all types of posts).....	p.6
Totem operator installation (on all types of posts).....	p.7 to p.8
Installing the gate (on all types of posts).....	p.8 to p.9
Finishing clips.....	p.10
Installing the opening stop.....	p.10
Installing the closing stop (on aluminum posts).....	p.11
Installing the closing stop (on existing posts).....	p.11
Receiver box adjustment.....	p.11
Setting the limit-switches.....	p.12
Connection plan.....	p.13
DIPS switch factory settings.....	p.13
IMPORTANT : Flashing amber light and cells installation.....	p.14
Outdoor antenna installation.....	p.15
Self-learning.....	p.16
In case of a fault or before the self-learning cycle : Reset board	p.17
Radio receiver :	
- Transmitter programming.....	p.17
- Wireless keypad programming.....	p.18
- Deleting a key from the transmitter.....	p.19
- Deleting a channel.....	p.19
- Memory wipe.....	p.19
Options :	
- Connection : Pulse button.....	p.20
- Connection : Partial open button.....	p.20
- Connection : External antenna.....	p.20
- Connection : Battery.....	p.21
Breakdown assistance.....	p.22
Description of LED flashing sequences.....	p.22
Appendix.....	p.23 à p.24
In the case of an openwork gate.....	p.25

Required equipment

- | | | |
|--|-------------------|--|
| - Hammer drill | - Hammer/Chisel | - Tape measure |
| - Set of steel/concrete drill bits | - Spirit level | - Appropriate screws and pins for the supports |
| - Electric screwdriver with end-pieces | - Plumb bob | - 10 mm shims |
| - Allen keys + Flat wrenches | - Hacksaw | |
| - Flat screwdriver 2,5 mm | - Angle grinder | |
| - Wire stripper pliers | - Riveting pliers | |

Installation instructions



WARNING !

To ensure that this product is assembled, used and maintained in complete safety, it is important to follow the instructions provided in this document. For everyone's safety, observe the following precautionary measures.



- * Before beginning the assembly, read this manual carefully.
- * This fence element must be installed by a professional technician.
- * All the parts delivered are specifically sized for this product. Adding and/or using other parts may be detrimental to safety and may affect the product's warranty.
- * Any modification or improvement of this fence element must be compliant with the standard EN 13241 + A2. In this case, a "modification/transformation" file must be created by the installer as per the standard EN 12635 annex C.
- * Use the appropriate tools to install these products. Ensure that the work is carried out on a stable floor.
- * Ensure that the assembly area is clear, clean and clearly marked out.
- * Ensure that no other people are present at the assembly site apart from the installers. Non-authorized persons (children for example !) who are present at the site risk injury during assembly.
- * All the components of this fence element must be installed in compliance with the installation instructions provided in this manual.
- * All requirements of EN 13241 + A2 must be met and checked if necessary.

Electrical duct installation

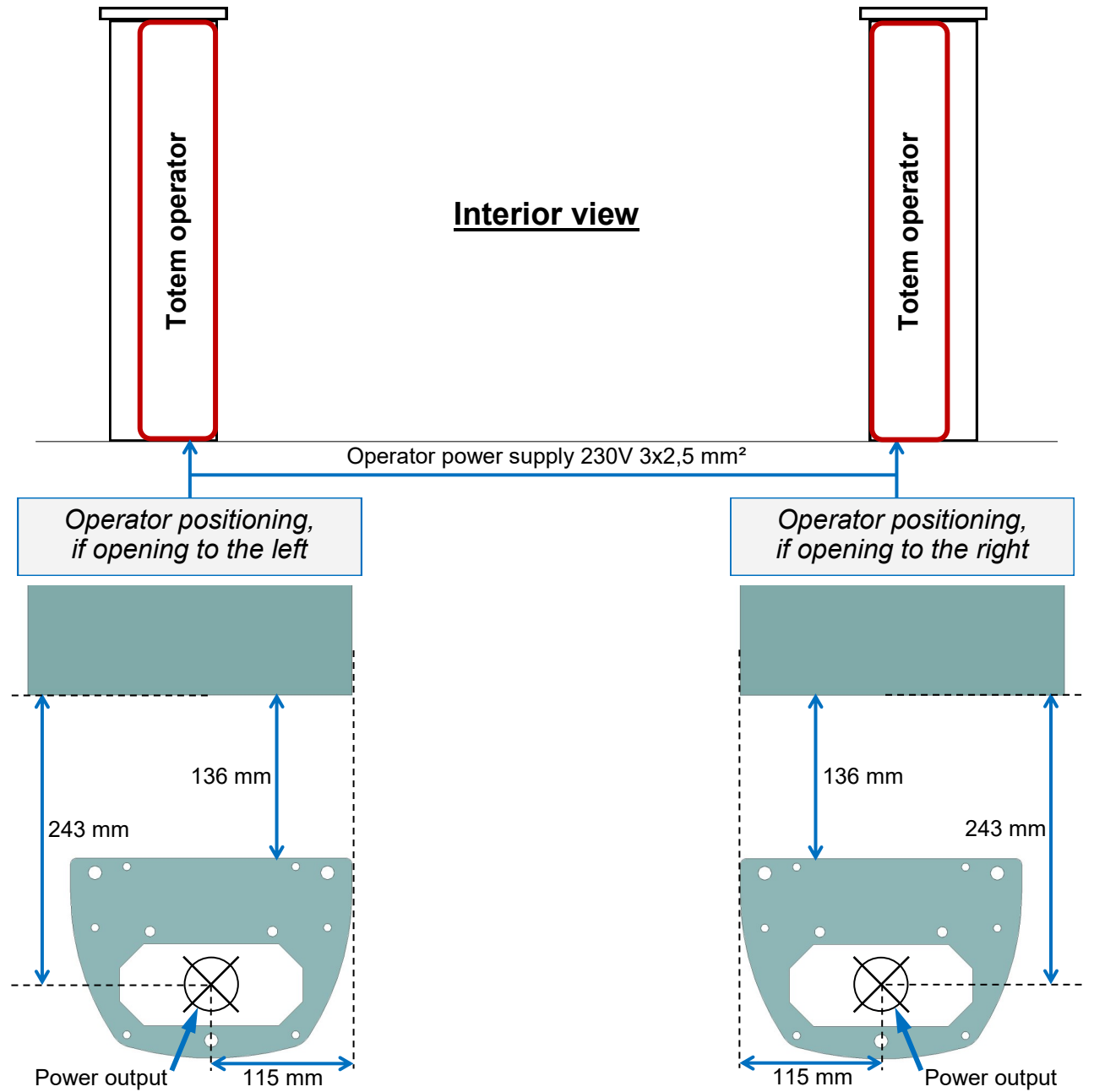

Assembling + installing the aluminum posts (Option)

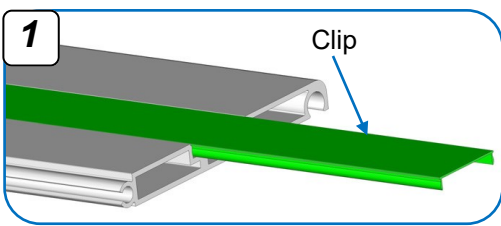

*Remove clips
before the profiles are assembled*

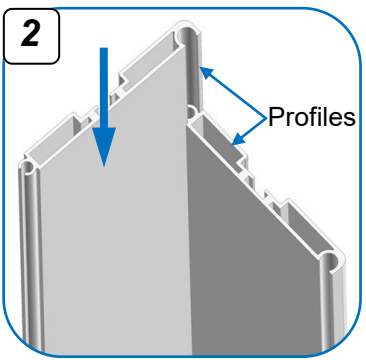

Assemble the profiles

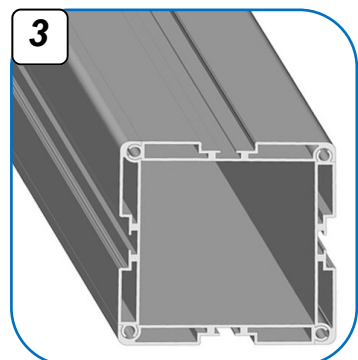

Assembled posts

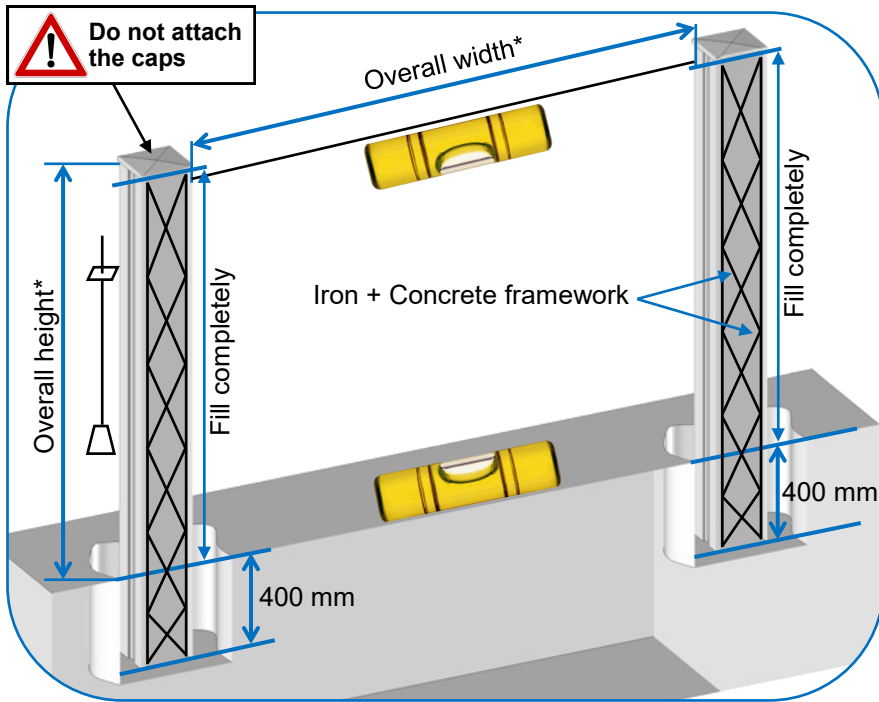

* Overall width and height correspond to the order dimensions.

!
It is essential to check the plumb line of the posts on all sides. The 2 posts must be at the same level and correctly aligned.

Please note :
Before installing the gate, check that the concrete/post is completely set (21 days to dry on average).

Once the installation is complete, cut the attachment clips according to the height of the posts, then click them onto the posts.

Check of existing posts

Checking worksite dimensions

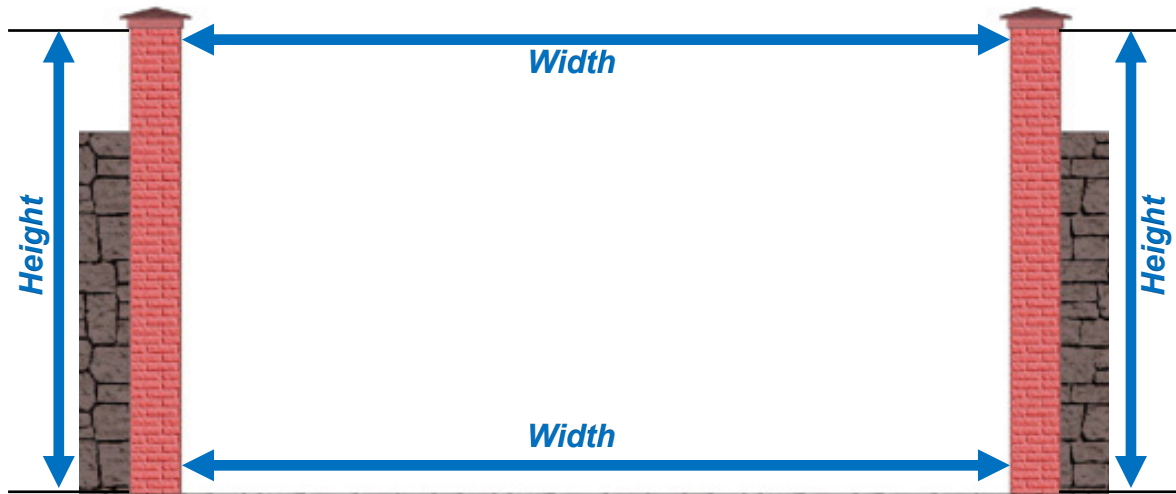

Check under hat :
Width between posts and height of posts

Checking level 0, plumb and alignment of posts

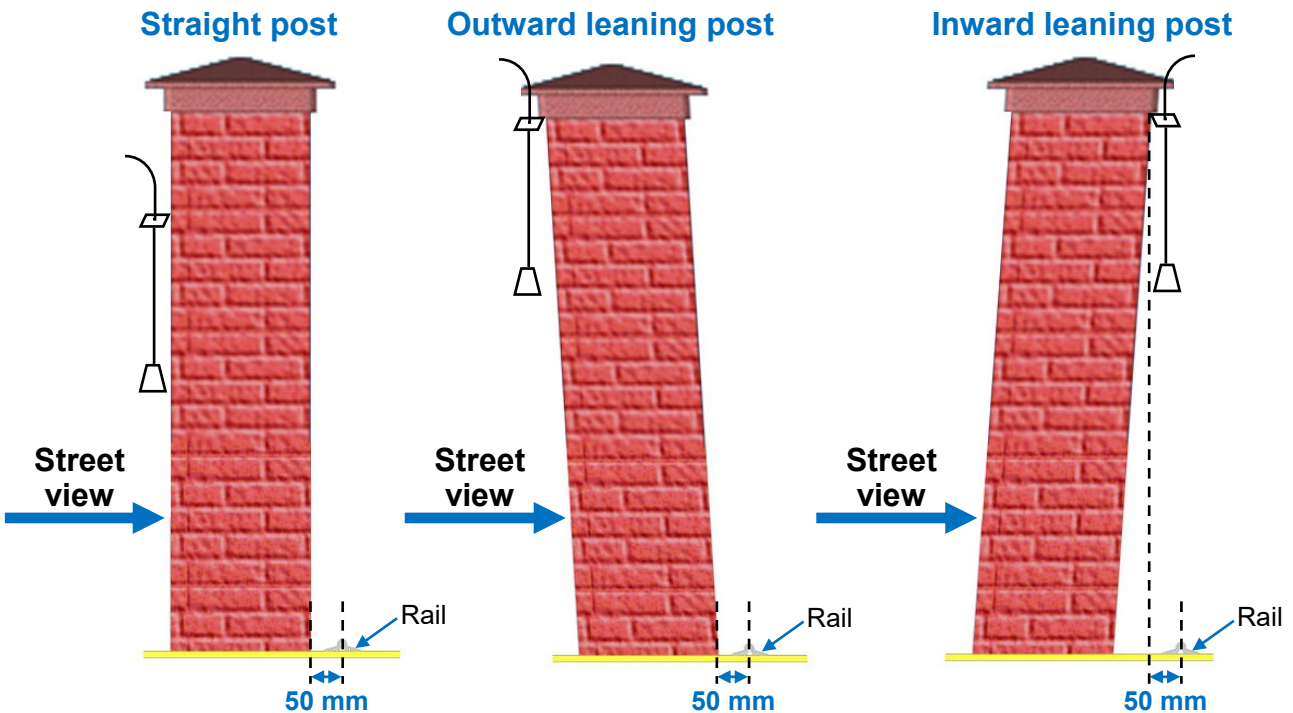
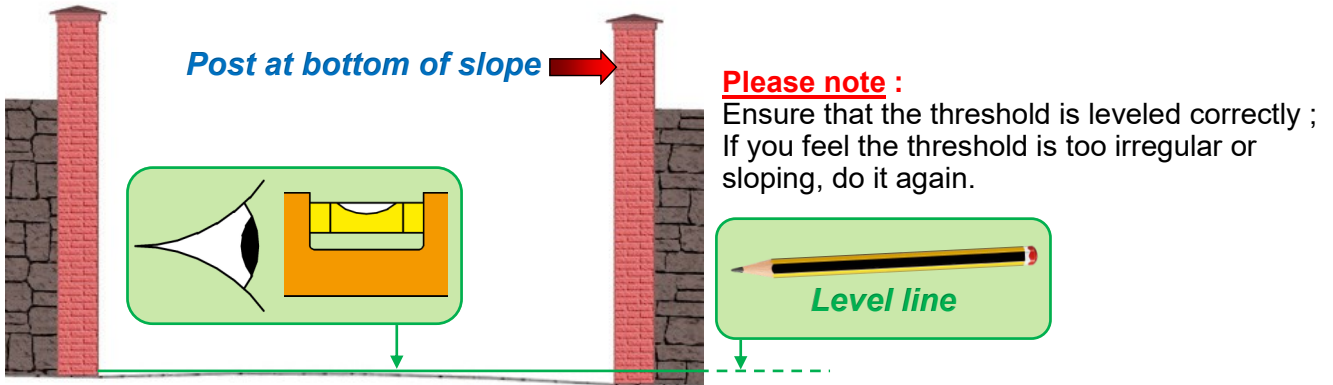

Guide rail attachment (on all types of posts)

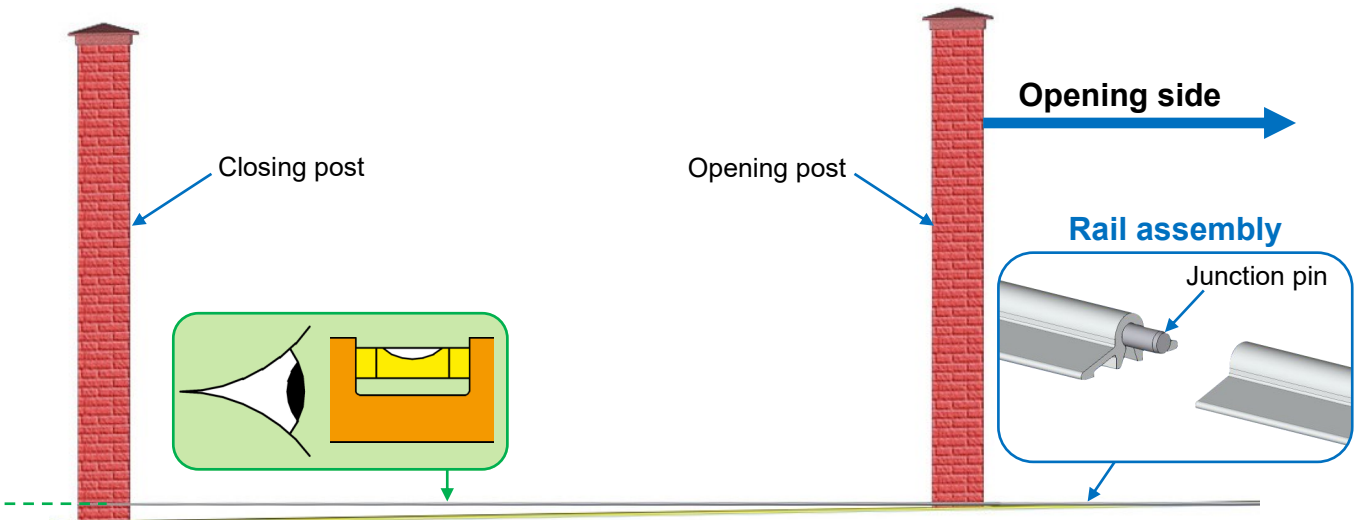

Attach the rail from the closing post ; Using the 8 mm pins and suitable screws (not supplied).

Totem operator installation (on all types of posts)

Floor fittings

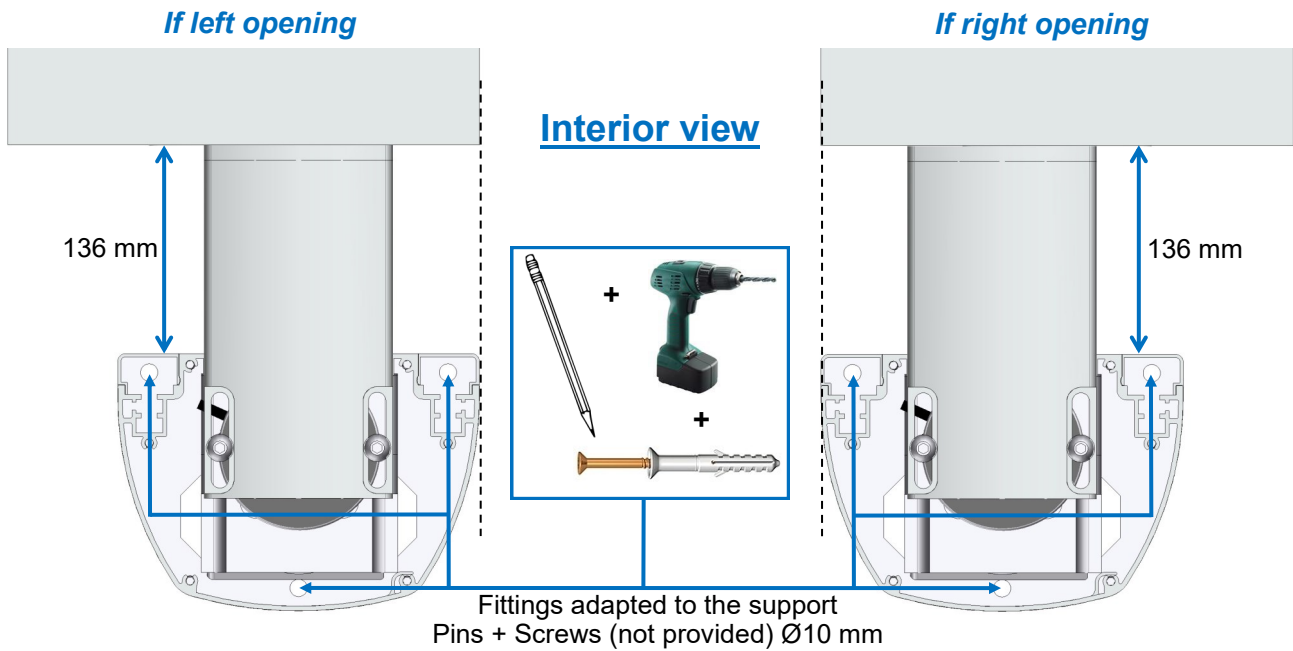

Please note : Attach the Totem operator to a single point, so that it can be removed more easily later.

Anti-vibration plate attachment

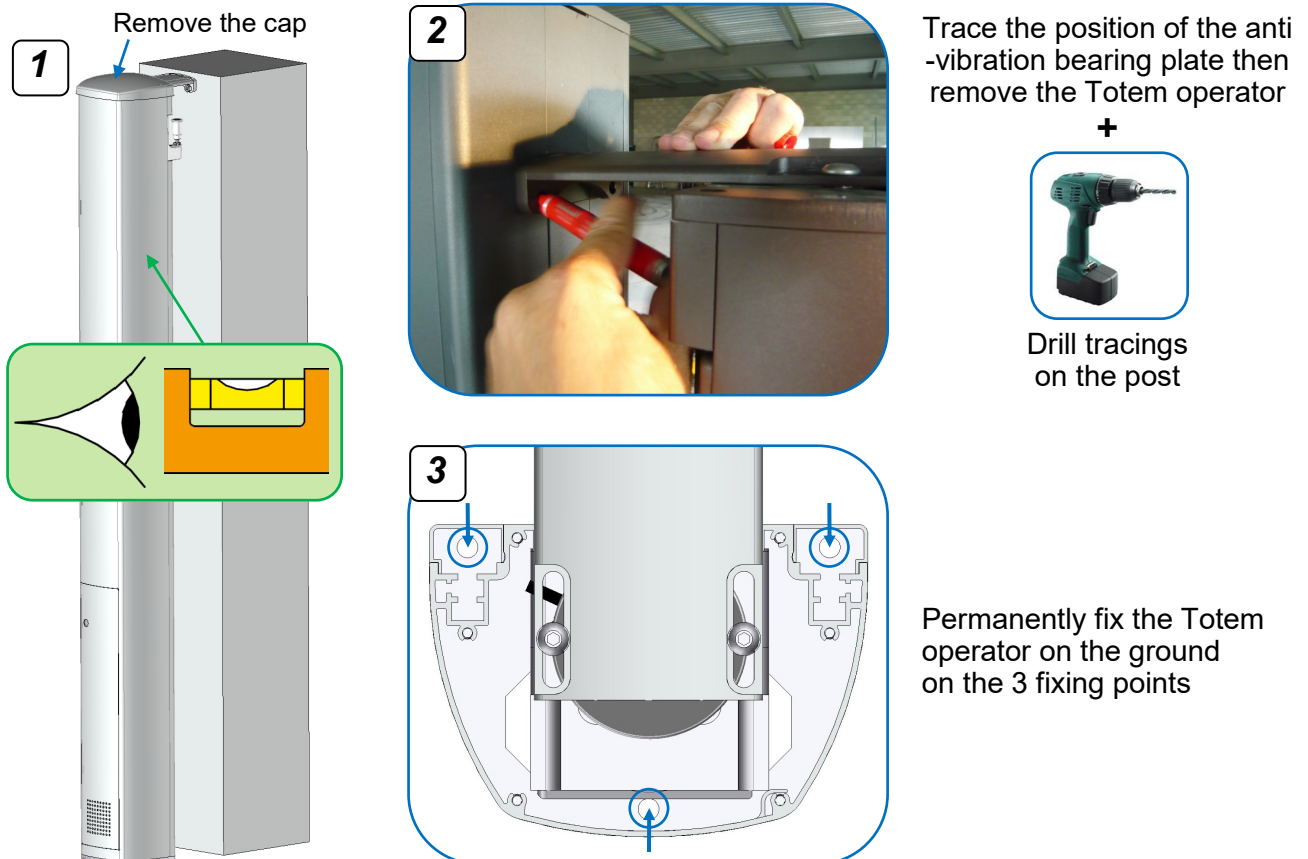

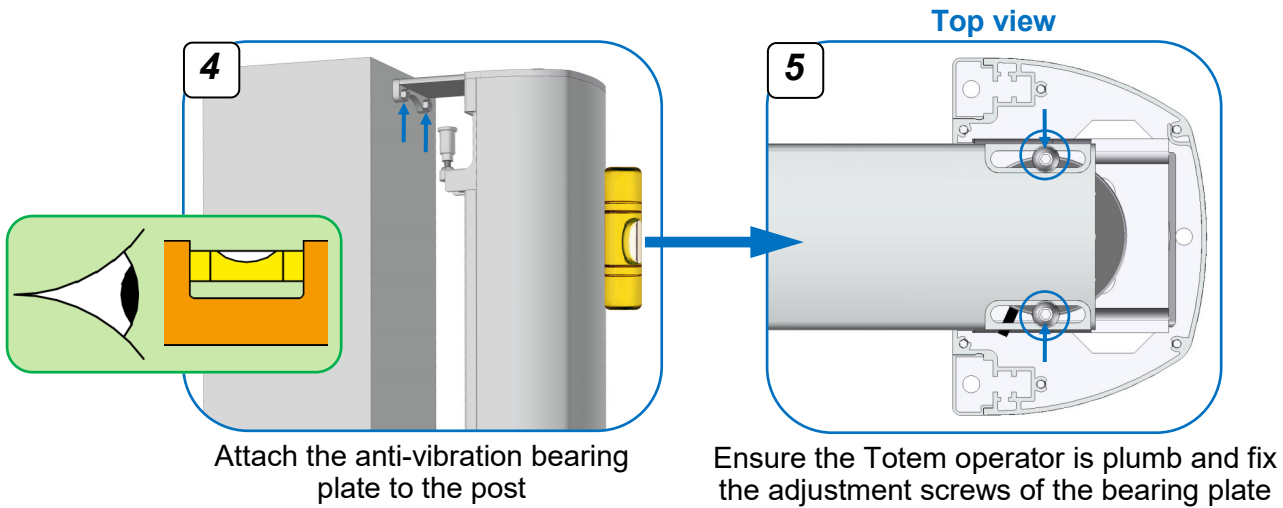

Installing the gate (on all types of posts)

Attach wheel covers

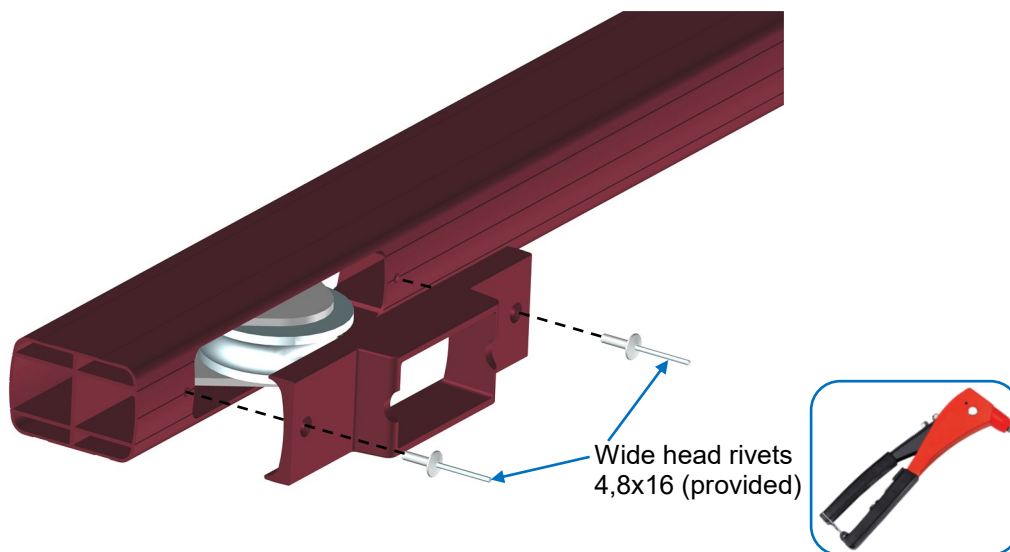

Place the gate

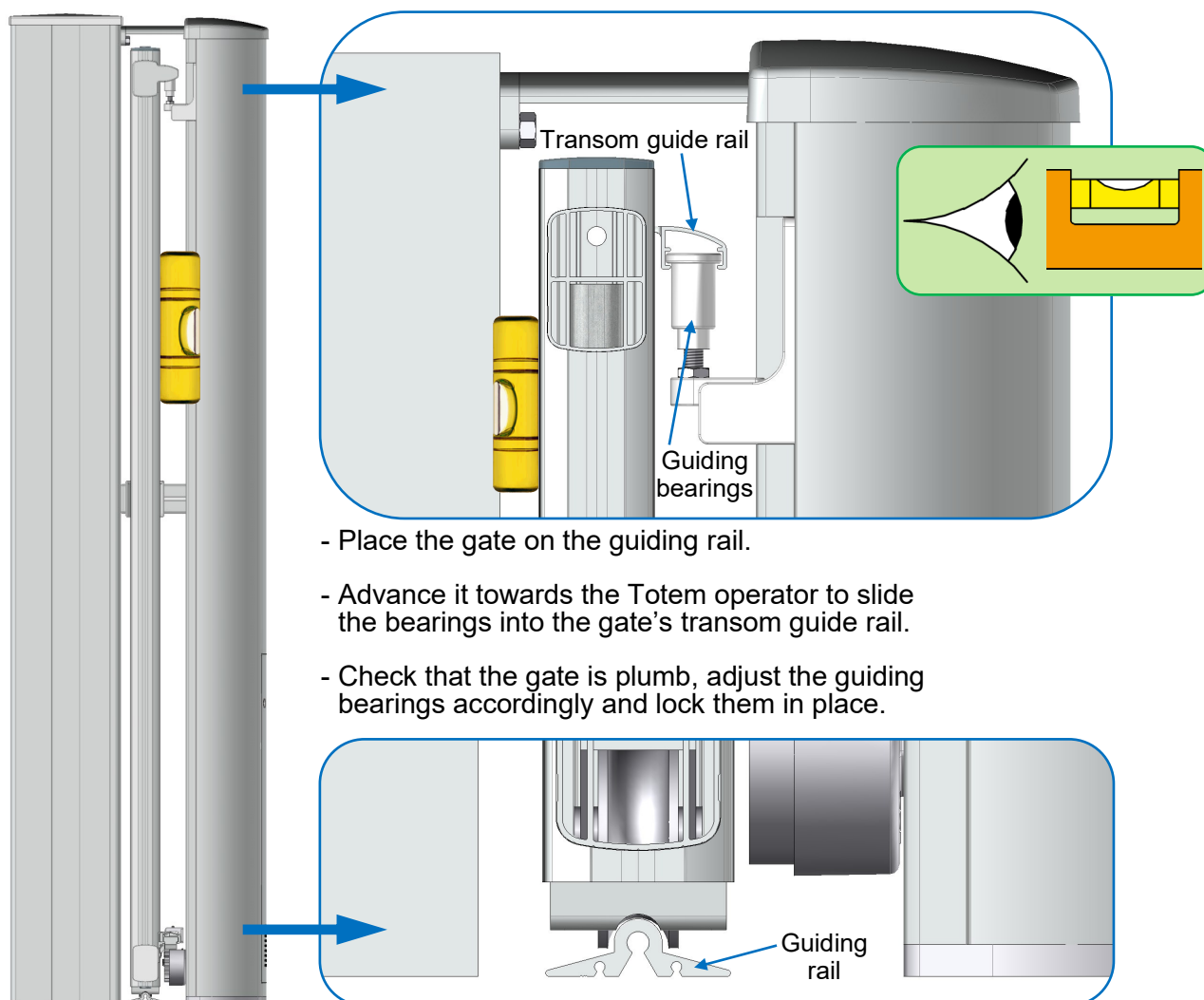

Adjust the rack

Please note : Check that the operator is disengaged (clutch lever in down position).

Please note² : The height of the operator sprocket is preset at the factory.

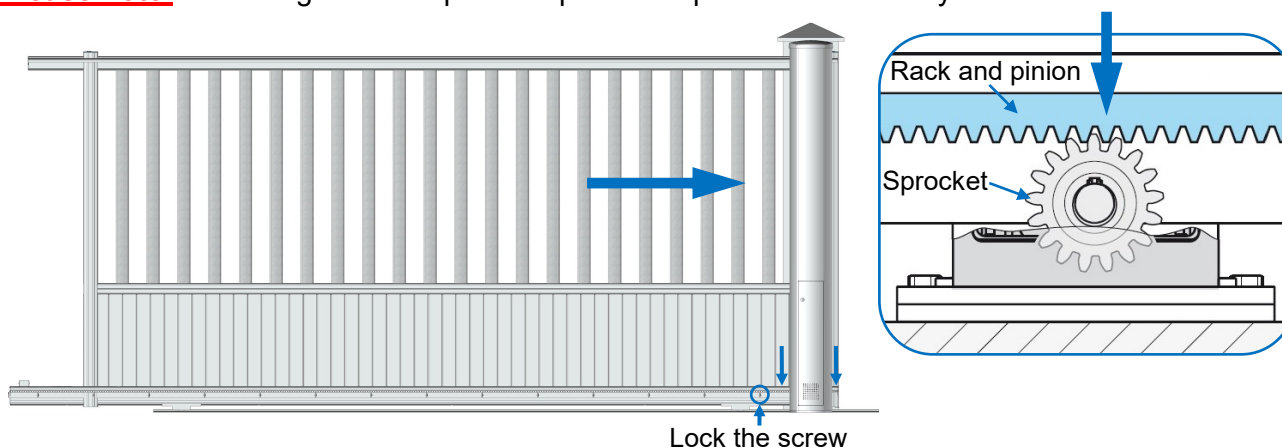

- Gate open, press the rack and pinion on the sprocket so that the notches of the rack and pinion coincide with the notches of the sprocket and lock the screw.
- Unwind the gate as you go until it closes and repeat the above step until all the rack and pinion screws are tightened.

Finishing clips

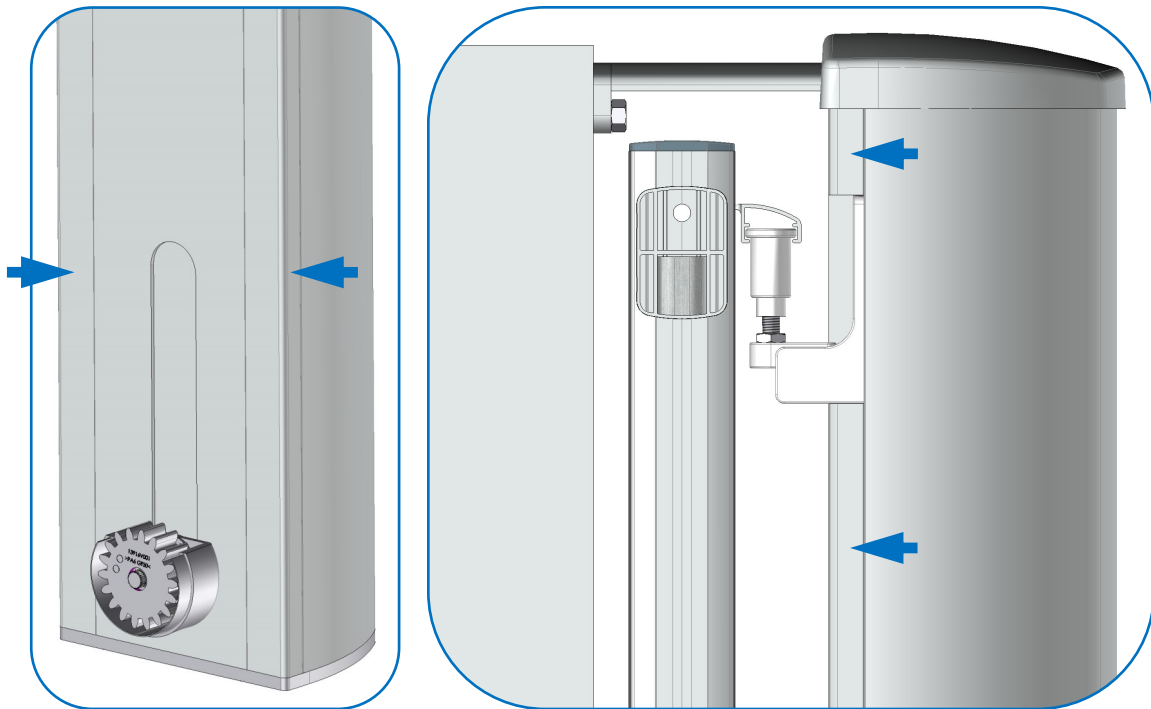

- Mount the finishing clips on the Totem operator.
- Cut the clip around the guide rollers.

Installing the opening stop

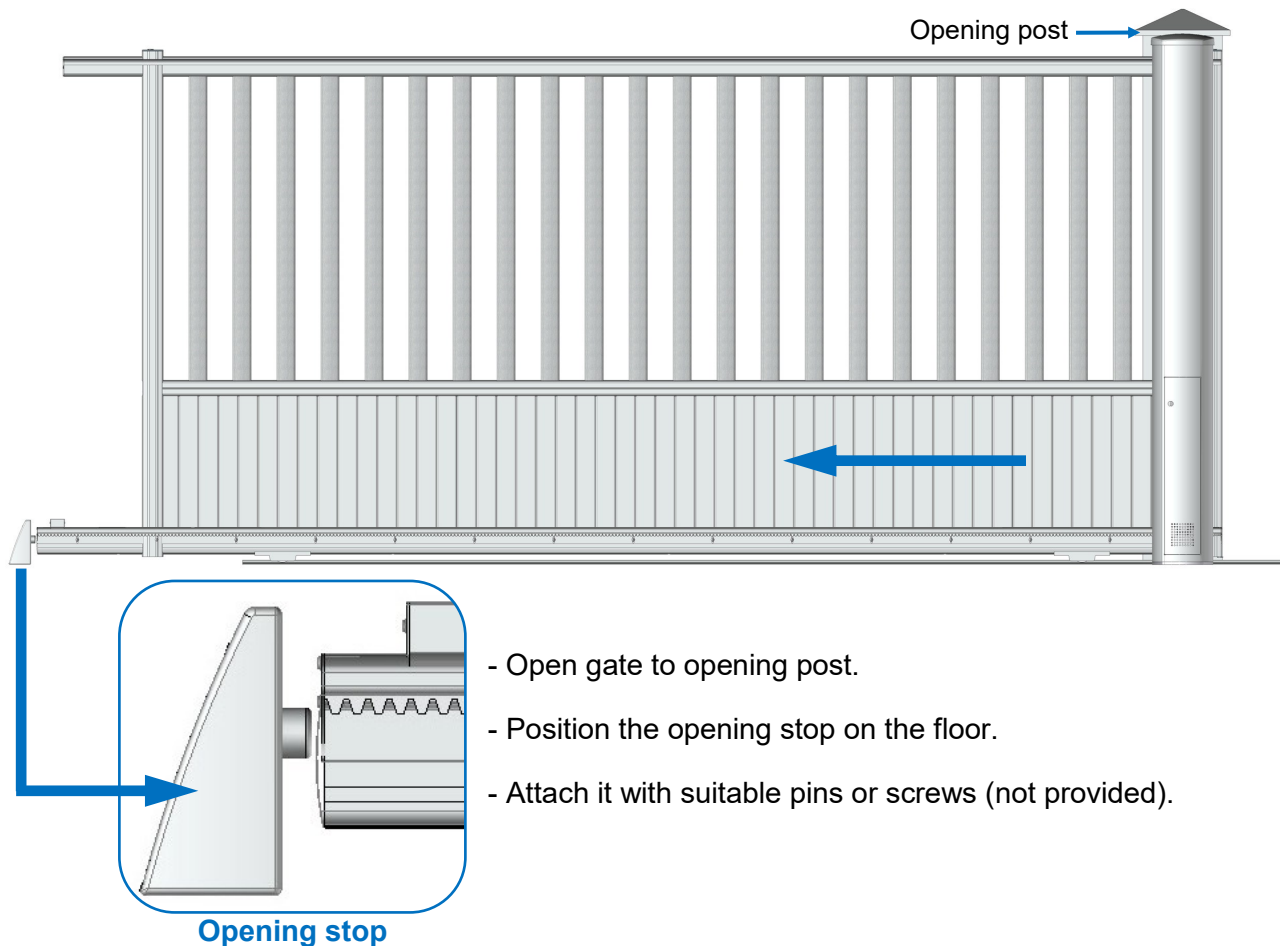

- Open gate to opening post.
- Position the opening stop on the floor.
- Attach it with suitable pins or screws (not provided).

Opening stop

Installing the closing stop (on aluminum posts)

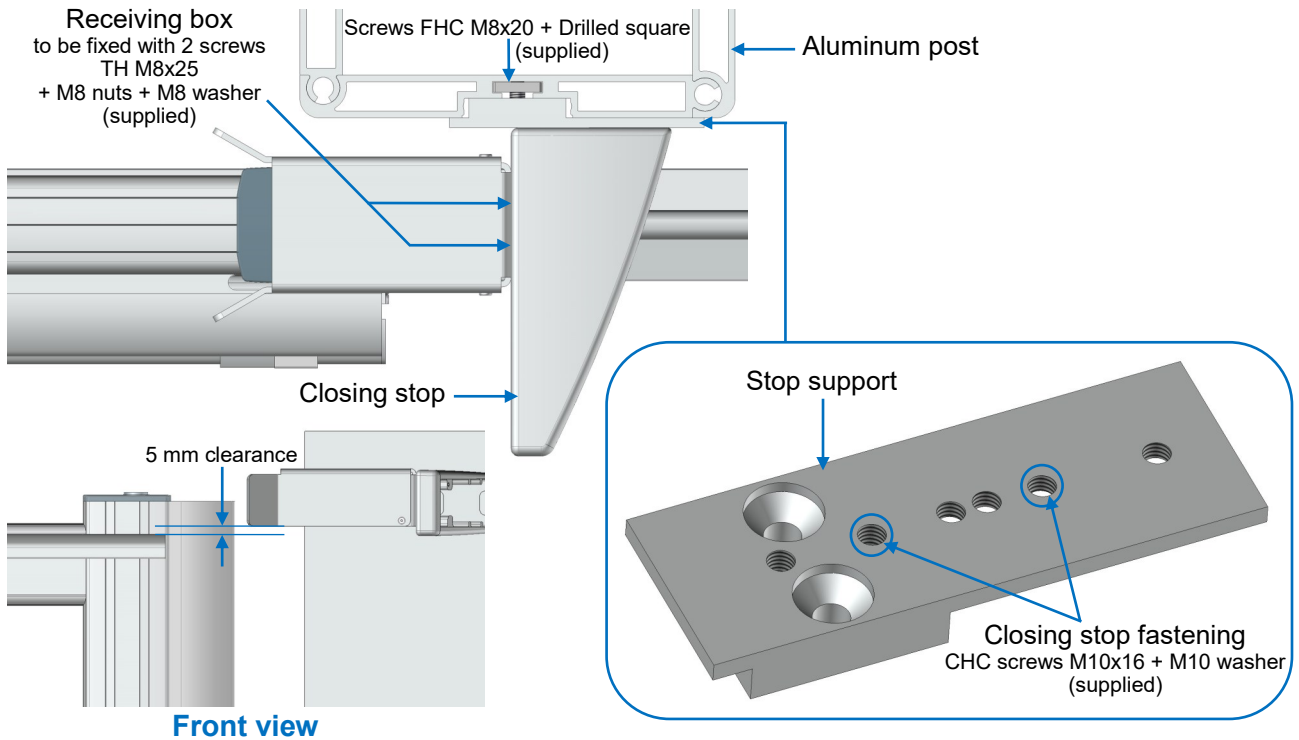

Installing the closing stop (on existing posts)

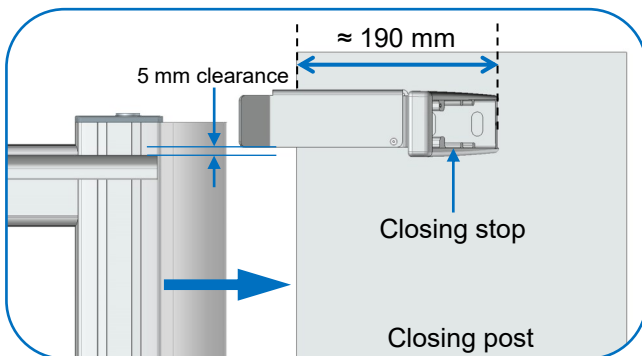

- Close gate to closing post.
- Position the closing stop on the post at the top of the gate.
- Secure it with pins and screws suitable for the support (not provided).

Receiver box adjustment

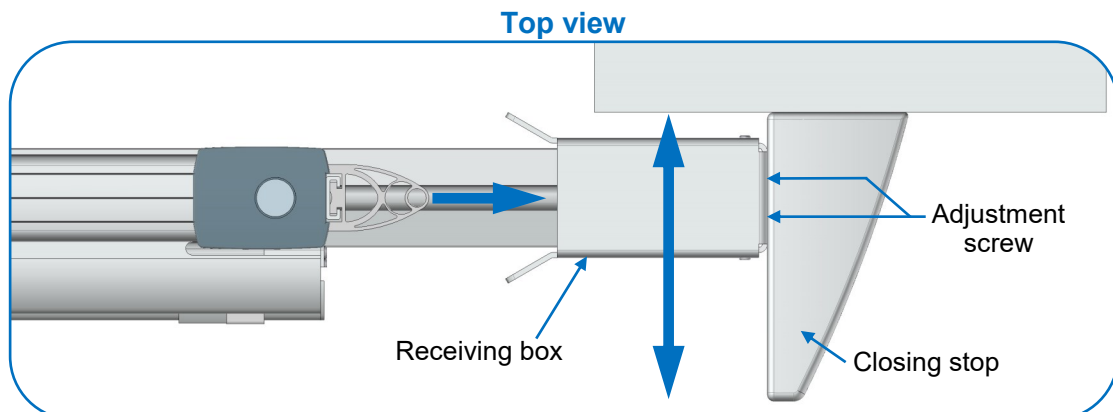

- Adjust the receiving box in line with the gate using the 2 screws inside the closing stop.

Setting the limit-switches

- Open the operator cover and connect the 230V mono 50Hz mains power supply using the plug supplied.
Comment : If the cells are not installed, the wireless accessory management board will beep.
- Fix the magnet on its support with the TF 4,2x25 auto screws (supplied).
Please note : To adjust and fix the magnet support to the rack and pinion follow steps 2 and 3.

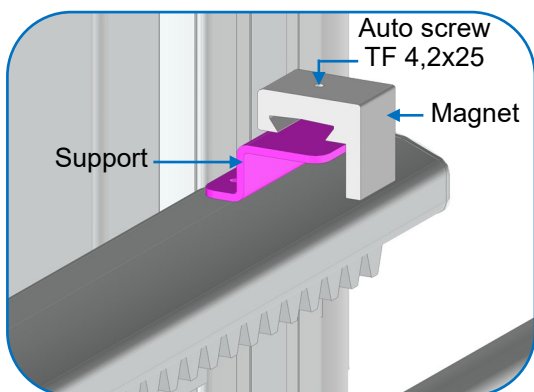

1 Unlocking the operator

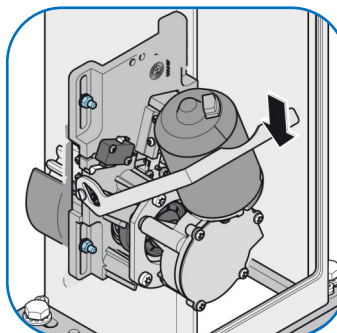

2 Adjustment of the closing or opening limit-switch (depending on the operator side) :

- Open or close the gate (1) to position the left limit switch (2).
- Set the magnet support (3) on the sensor to switch (red LED lights up).
- Attach the magnet support to the rack and pinion with the 2 screws TF 4,2x16 (supplied).

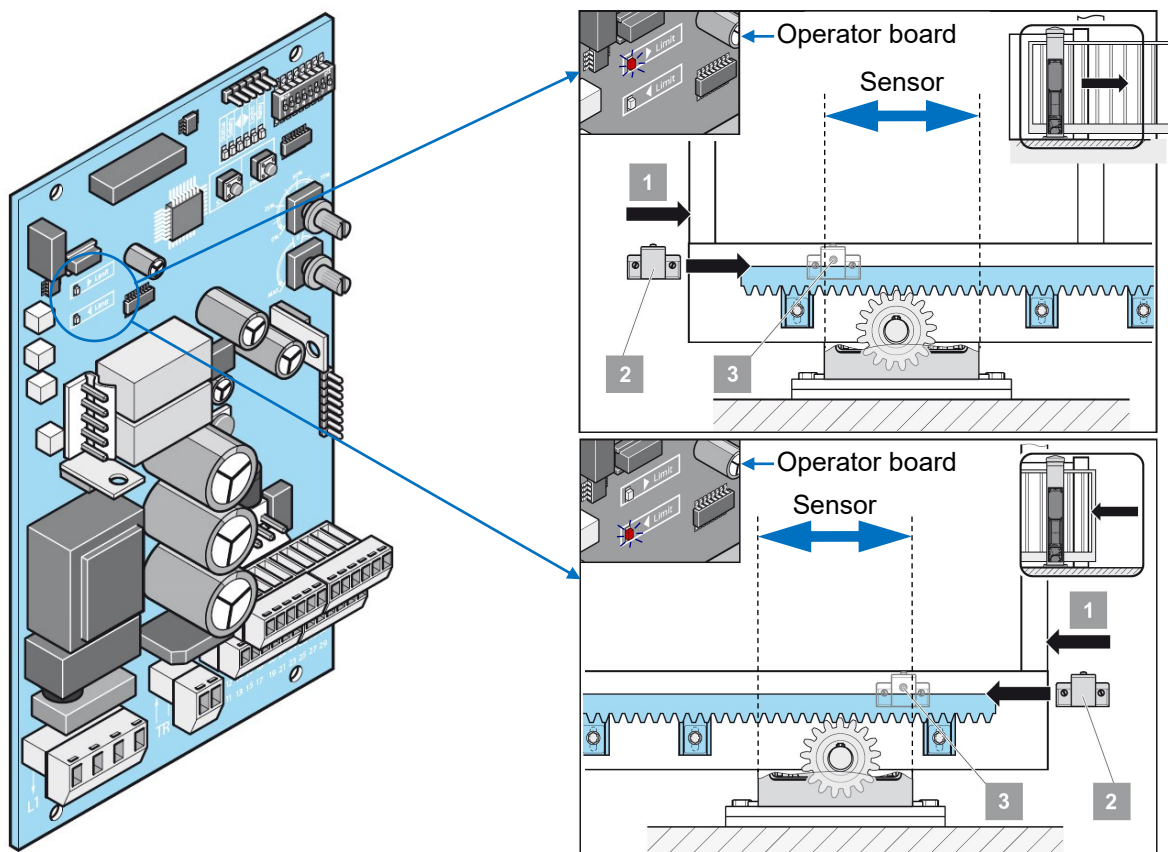

3 Adjustment of the closing or opening limit-switch (depending of the side of the operator) :

- Push the gate in the other direction (1) to position the right limit switch (2).
- Set the magnet support (3) on the sensor to switch (red LED lights up).
- Attach the magnet support to the rack and pinion with the 2 screws TF 4,2x16 (supplied).

Connection plan

Power supply 230V

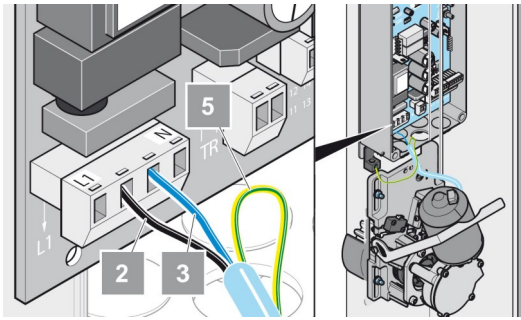

- 2- Phase L1 (black)
- 3- Neutral N (blue)
- 5- Earth (green/yellow)

Please note : 20V output, terminals 8/10

Board (wireless accessory management)

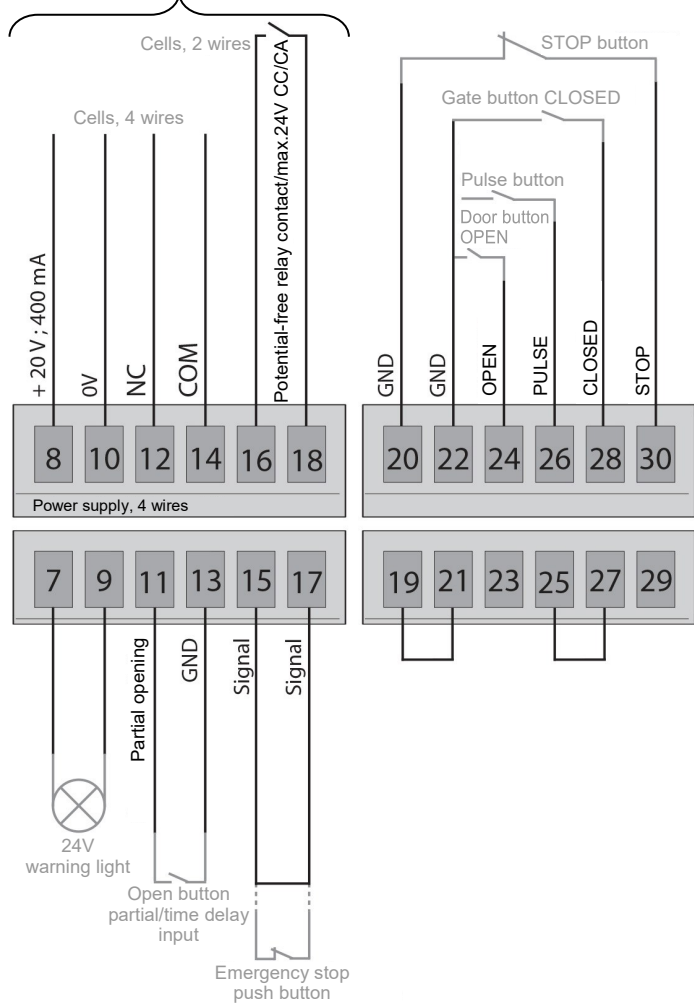

DIPS switch factory settings



- Position switch 7 according to the opening direction.
- Check switch 8 whether it's ON.

Switch	ON	OFF	Description
1		X	Hold to run mode deactivated If ON : Hold to run mode activated
2		X	Reaction to input safety contact strip / switch-off Partial reversal If ON : Full reversal
3	X		Locked weight potentiometer (Never switch to OFF)
4	X		Reaction of the cells during closure Full reversal If OFF : Partial reversal
5	X		Sleep off If OFF : Sleep enabled
6		X	The triggering of the cells starts a time delay (gate open) If ON : The gate closes 5 seconds after passing through the cells
7			ON : Left opening gate (exterior view) OFF : Right opening gate (exterior view)
8	X		ON : Pre-alert timeout enabled If OFF : Early warning time is disabled

Please note : Wireless accessories are pre-programmed at the factory.

IMPORTANT : Flashing amber light installation



- 1- Unscrew and remove the orange cover.
- 2- Unscrew and remove the board.
- 3- Place the batteries.
- 4- Screw the board and the orange cover back on.
- 5- Attach the flashing amber light assembly to the post.

Installing the cells

TX : Transmitter cell

RX : Receiver cell

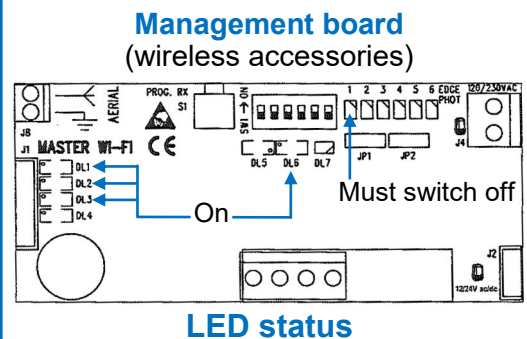
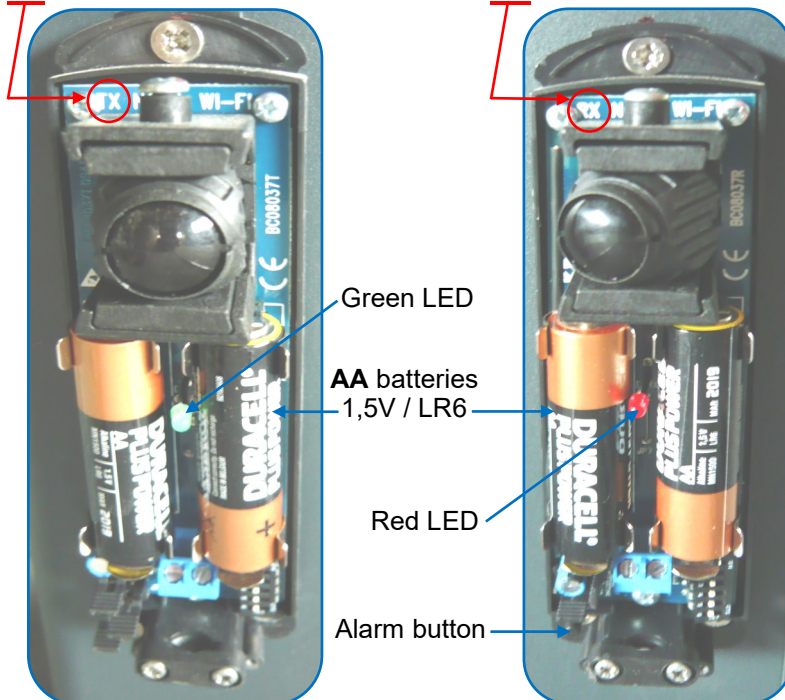

- 1- Install the batteries (the cell diode lights up for a few seconds and then turns off).
 - 2- Insert the TX transmitter cell (green diode) and fix it.
 - 3- Next, place the RX receiver cell (red diode) so that its LED lights up (cells aligned) and then fix it.
- Please note :** If after a few minutes the RX cell goes into standby, reactivate it : Remove the battery and then put it back in (or press the alarm button) and repeat step 3.

Outdoor antenna installation

Step 1 : Installing the antenna.

- Mount the antenna on the bracket, following the mounting order as below.
- Fix the bracket to the Totem (screws to be adapted, not supplied).
- Pass the antenna cable through the cap openings in the back.
- Lower the cable inside the Totem and insert it into the box through the cable glands.

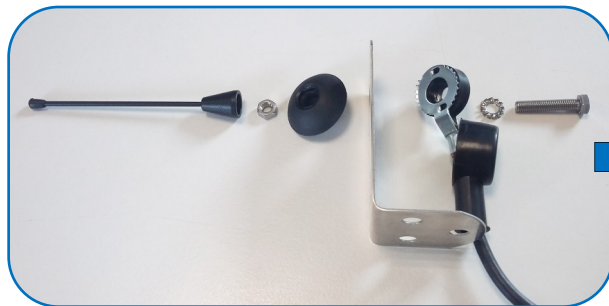

Assembly order



Step 2 : Remove the built-in antenna on the MASTER control board.

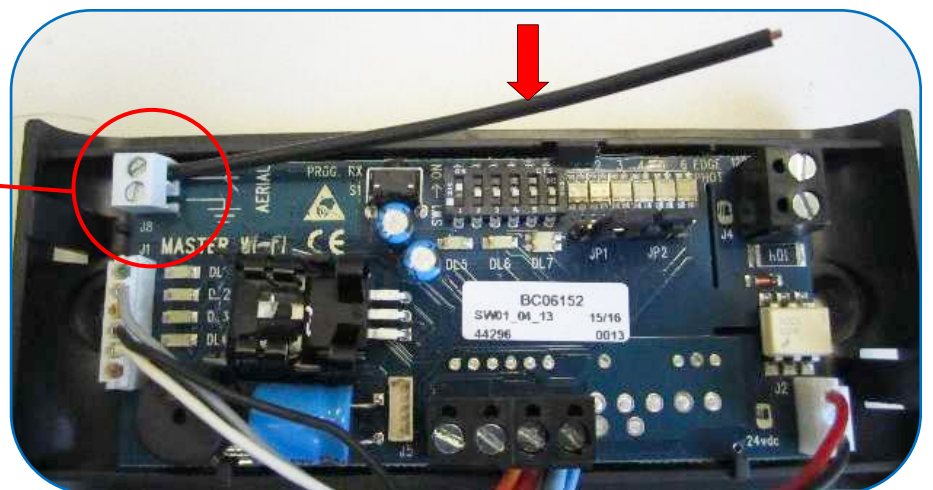
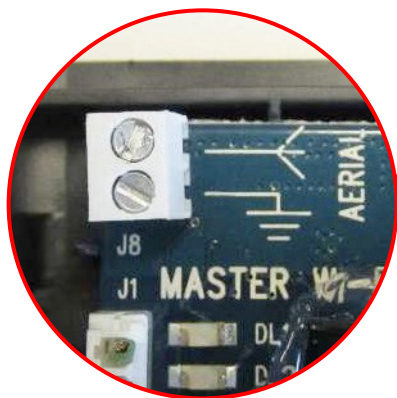

Step 3 : Wire the outdoor antenna to the MASTER control board.

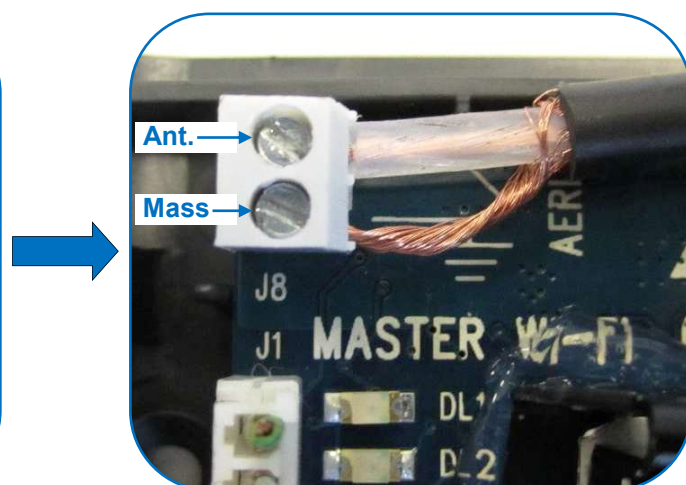
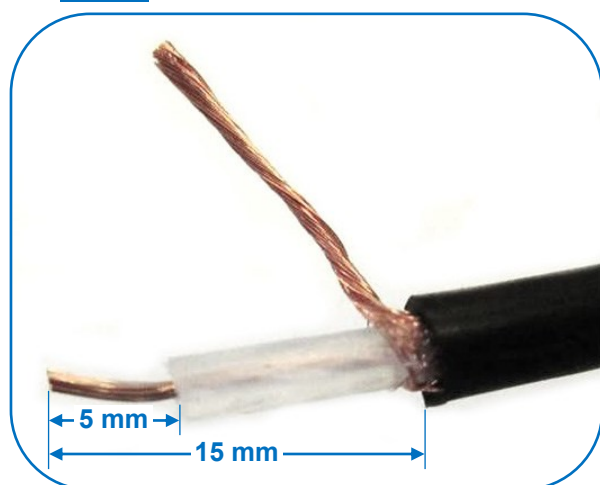

- Strip the outdoor antenna cable.
- Twist the strands together.
- Cut off the protruding strands.

- Connect the outdoor antenna cable :
Shield wire (outer braid) → to Mass.
Boundary wire (center wire) → to Ant.

Self-learning

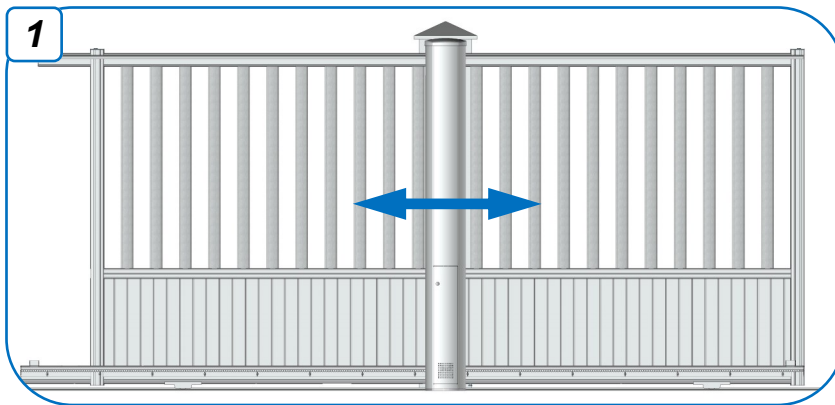

1 Move gate to intermediate position

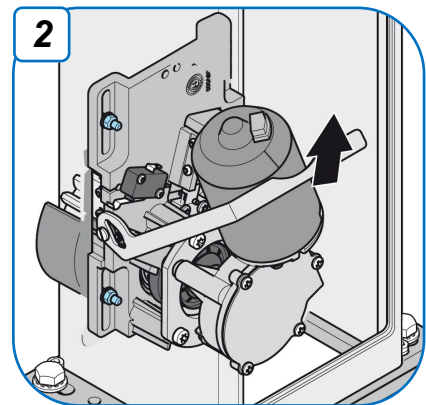

2 Lock the operator

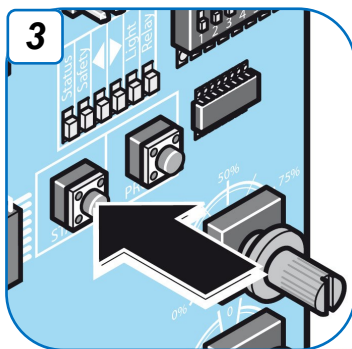

Please note : The learning cycles are in hold-to-run mode.
Please note² : Check that the LED "Light" is flashing, if not flashing, reset the board.
 (see chapter : Resetting the board).

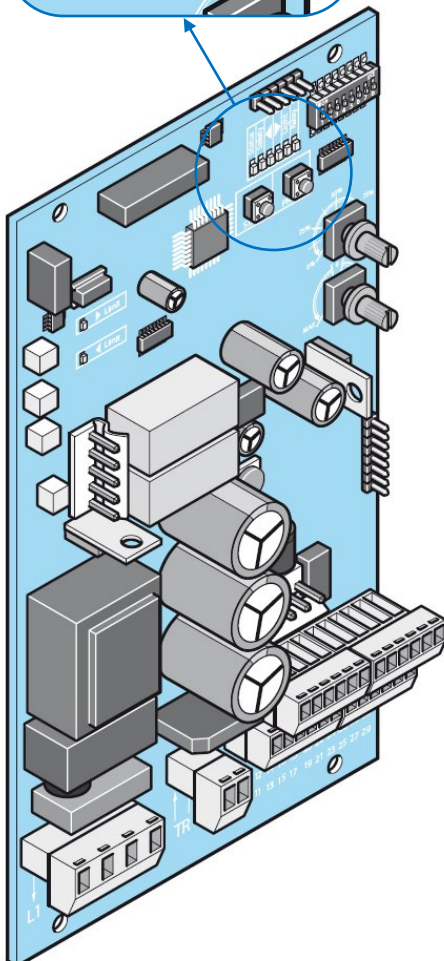

1- First learning cycle :

Measuring distance (it will be done at reduced speed).

- a) Press the START button, the gate moves to the opening limit stop (opening limit-switch LED lights up).
Please note : If the gate closes, re-set the **switch 7** (see chapter : DIPS switch settings).
- b) Wait for validation click (◀ and ▶ turn on and off).
- c) Press the START button, the gate moves to the closing limit stop (closing limit-switch LED lights up).
- d) Wait for validation click (◀ and ▶ turn on and off).

2- Second learning cycle :

Force measurement (slowing down at the end).

- Redo the same procedure : **Follow the steps of the first learning cycle (a, b, c and d).**

Information : After the 2 learning cycles have been completed, the "Light" LED must go out ; the learning cycle is completed.

Please note : If the "Light" LED stays on, repeat the entire learning cycle again.

In case of a fault or before the self-learning cycle : Reset board

Please note : A reset is only possible when the operator is locked and the 230V voltage is present (not possible on battery function).

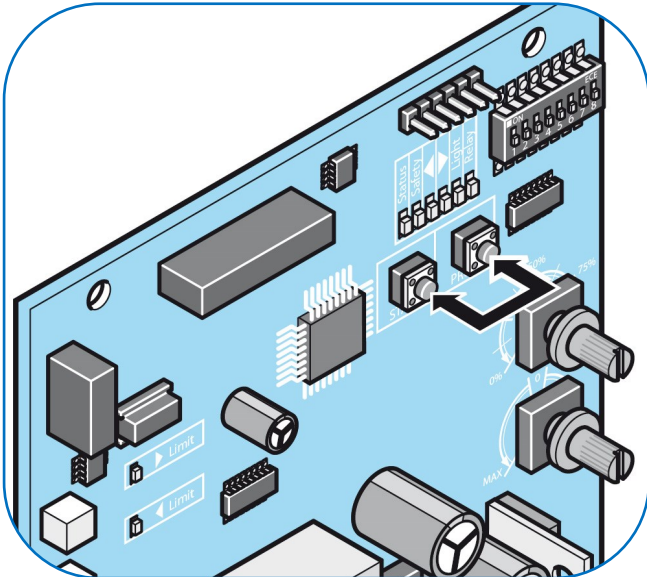

- Press the START and PROG buttons simultaneously and hold them down.
Please note : The "Light" LED starts flashing.
- Release the buttons while the "Light" LED is still on.
- Reset is complete and the LED "Light" is flashing.

Radio receiver

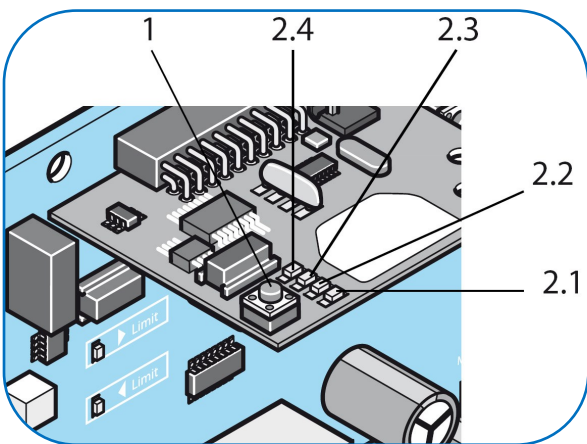

- 1- Programming button.
- 2.1- LED radio channel 1 : **Pulse mode**
(Open - off - closed - off - open - etc...)
- 2.2- LED radio channel 2 : **Partial opening**
(Pedestrian opening)
- 2.3 and 2.4- LED radio channel 3 and 4 : **Not used**

Transmitter programming

Move gate to closed position.

 **Once the channel is selected, you have 10 seconds to perform the next operation, otherwise the programming of the receiver will be cancelled.**

Pulse mode

- Press the programming button (1 time for channel 1, LED 2.1 lights up).
Please note : If LED 2.2, 2.3 or 2.4 lights up, continue to press until LED 2.1 is reached.
- Select a key on the transmitter and hold it down until LED 2.1 goes out.
- Programming in pulse mode is complete.

To program additional pulse emitters, repeat the above steps.
(112 memory entries are available).

Partial opening (Factory default ≈ 20% of gate length)

- Press the programming button (2 times for channel 2, LED **2.2** lights up).
Please note : If LED **2.1**, **2.3** or **2.4** lights up, continue to press until LED **2.2** is reached.
- Select another key on the transmitter (different from the pulse mode) and hold it down until LED **2.2** goes out.
- Programming for partial opening is complete.

To program additional transmitters for partial opening, repeat the above steps.

Changing the partial opening distance

Step 1 : Clear current value.

- **Gate closed**, press and hold down the PROG button + The programmed partial opening button of the transmitter, for 2 seconds.
- The "Light" LED lights up.
- Release the keys, you hear a confirmation click.
- The opening recorded value is canceled.

Step 2 : Program the new desired opening distance.

- Press the same key (Partial open) on the transmitter, the gate will open.
- At the desired distance, press the (Partial open) button on the transmitter again, the gate stops.
- Press the (Partial open) button on the transmitter, the gate closes again and confirms the opening distance.

Automatic mode

To activate this mode : The pulse mode must be programmed or partial opening.

- Turn the potentiometer to the right until the desired delay time.

Please note : Potentiometer turned to maximum ≈ Timer 5 minutes.

- Perform a validation cycle to check for proper operation.

Please note : If the potentiometer remains on the **value 0**, the gate will remain in sequential operation for pulse mode and partial opening.

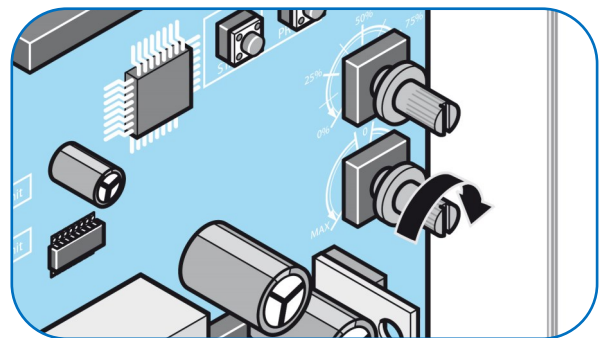

Wireless keypad programming

- **For the installation and programming of the keypad**, see the instructions enclosed in the accessories package, entitled : 10-function wireless keypad connection instructions.

Deleting a key from the transmitter

⚠ To remove all the keys from the transmitter, repeat the steps below for each key.

- Press the programming button (1) and hold it down for 5 seconds (one of the LEDs flashes).
- Release the programming button (1).
- Press a key of the transmitter to be deleted (LED goes out).
- The deletion of a key is complete.

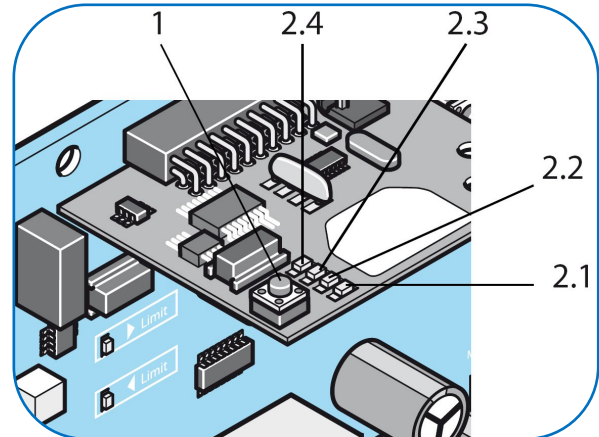

Deleting a channel

- Press programming button (1) and hold it down after selecting the channel.
 - 1 time for channel 1, LED 2.1 lights up : **Pulse mode.**
 - 2 times for channel 2, LED 2.2 lights up : **Partial opening.**

Please note : If LED 2.3 or 2.4 lights up, continue to press until LED 2.1 or 2.2 is reached.

- The LED flashes after 5 seconds and then lights up after another 10 seconds.
- Release the programming button (1).
- Deleting a channel is complete.

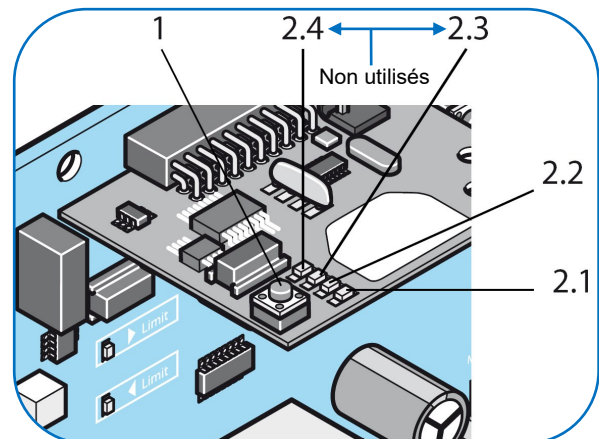

Memory wipe

- Press the programming button (1) and hold it down.
- The LED flashes after 5 seconds, then lights up after another 10 seconds and finally after 25 seconds all LEDs light up.
- Release the programming button (1).
- Memory wipe is complete.

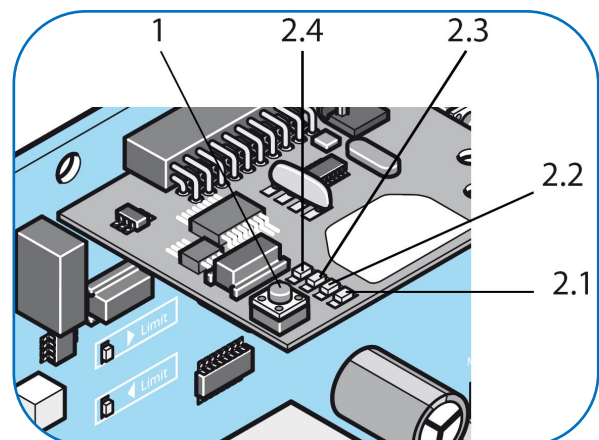

Options

Connection : Pulse button

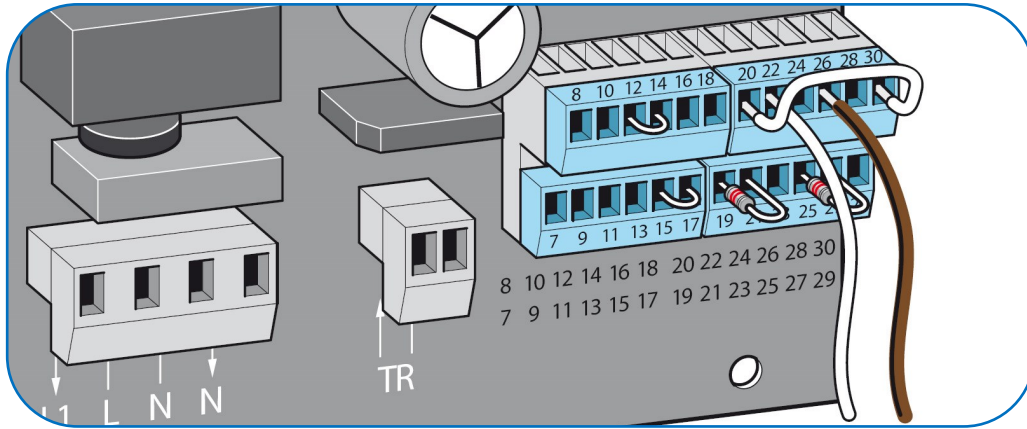

Terminals 22 and 26

Connection : Partial open button

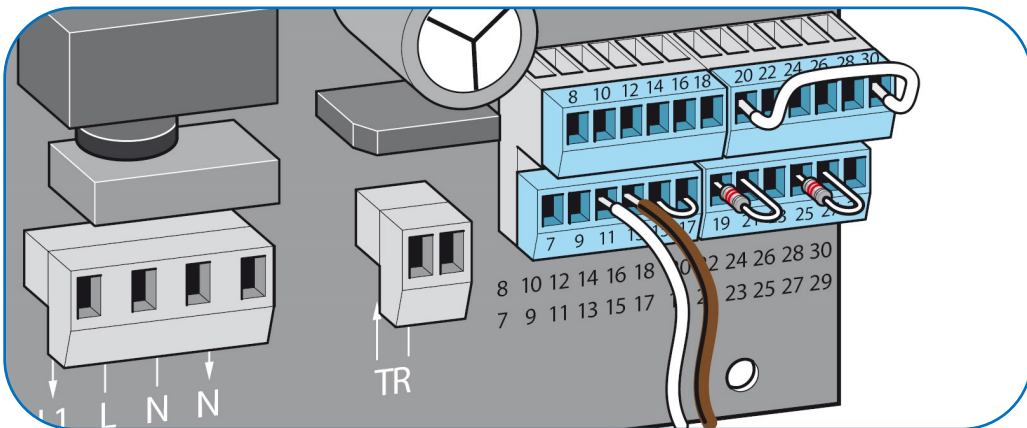

Terminals 11 and 13

Connection : External antenna

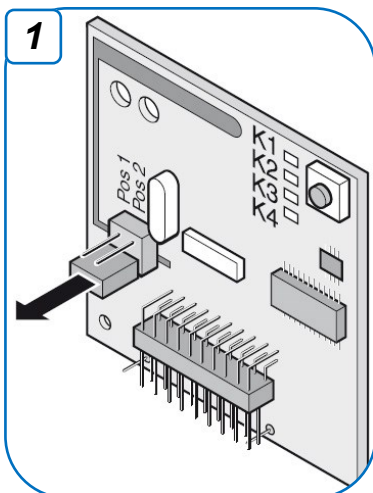

1 Remove jumper from pins

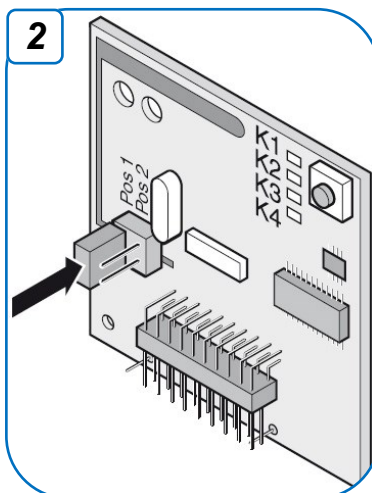

2 Set jumper to "Pos 1"

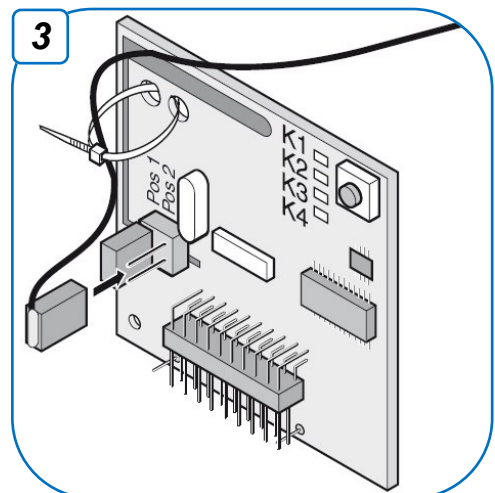

3 Plug the external antenna connector to "Pos 2"

Connection : Battery

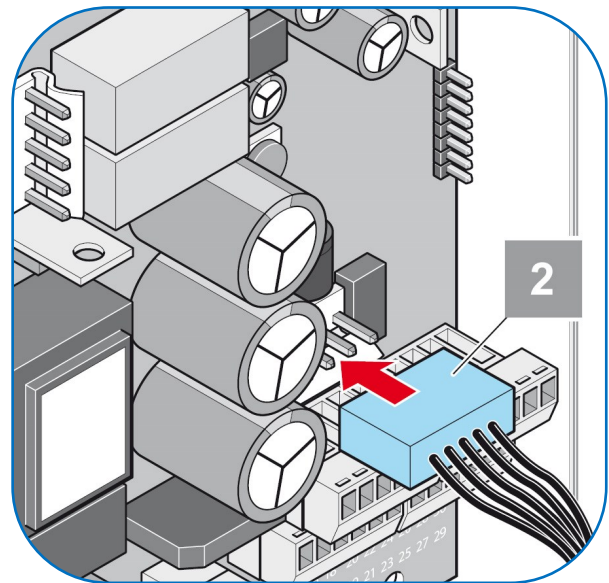
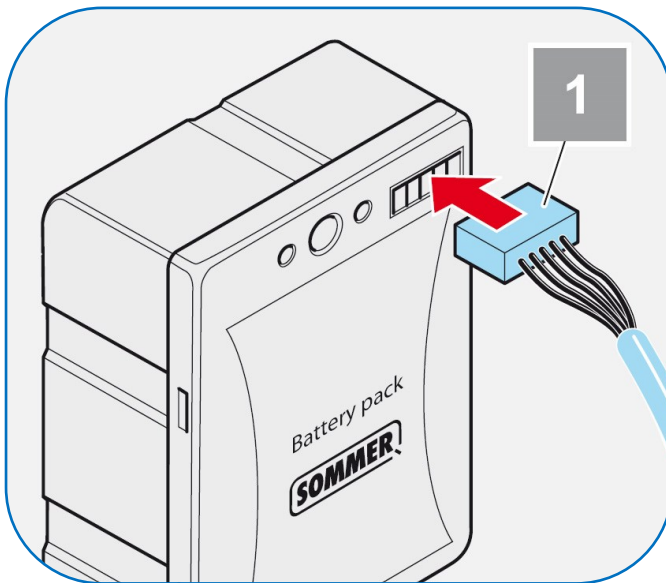

IMPORTANT : For a 1^{ère} use, the battery must be charged for at least 24 hours.

- Turn off the power.
- Connect the connecting cable to the battery (1).
- On the board, in the Totem operator, connect the other end of the connecting cable (2).
- Install the battery in the jamb (3).
- Restore power.

Test cycle :

- Perform a complete power cycle (Open + Close).
- Start a new cycle and turn off the power while moving.
Please note : The battery is detected and activated.
- Restore power.
- Close the box lid.
- Close the Totem operator with the vent plate and lock the lock.



Breakdown assistance

Malfunction	Possible cause	Solution
The gate does not reverse its movement on contact with the object	- The gate is poorly adjusted	- Resume gate setting and perform self-learning
Operator unlocks, the gate opens and closes with difficulty by hand	- Faulty emergency release - Gate locks up	- Repair the emergency release - Check the gate (guiding rail, rollers, etc.)
The gate won't start	- Disengaged operator - The cells are on standby - Safety LED is on	- Disengage the operator. - Close the gate and issue a run command - Check the connection of the management board and the alignment of the cells
Cells (if existing) - Open/Close the gate over the sensors, safety LED does not light (depending on DIP setting 4)	- Cable breakage, loose terminals - Congested cells - Deregulated cells - Defective cells	- Check wiring, retighten terminals - Clean the cells - Align the cells - Replace cells
Automation fails to close the gate	- The electric power source of the cells is interrupted - Power failure - Power failure, when the gate was in the intermediate position and therefore switched to hold to run mode	- Check connection, replace fuse - Restore power, at 1st pulse given, the gate opens. - Move the gate in hold to run mode until the opening or closing run limit is reached and lock it.
The automated system opens the gate and then does not react to a command from the transmitter	- The safety input has been triggered (example : defective sensors), safety LED flashes	- Eliminate the obstacle obstructing the cells - Repair the cells - The transmitter was programmed incorrectly
The opening or closing speed varies	- The automated system starts and slows down before reaching the limit-switch	- Normal behavior, the automated system starts at maximum speed and then slows down before reaching the other limit-switch
The gate can only be operated as long as you keep the button of a transmitter pressed	- Hold to run mode activated	- Deactivate hold to run mode, see chapter DIP switch settings or correct the defective security device
All LEDs flash on the radio receiver	- All 112 entries (maximum) in memory are occupied	- Remove transmitters that are no longer in use - Install an additional radio receiver
One of the LEDs on the radio receiver stays on	- The radio signal is received, a button on the transmitter may be defective or there is an external signal	- Remove the battery from the transmitter - Wait until the external signal stops emitting
One of the LEDs on the radio receiver lights up	- The radio receiver is in programming mode and waits for a radio code from the transmitter	- Press the key on the transmitter

Description of LED flashing sequences

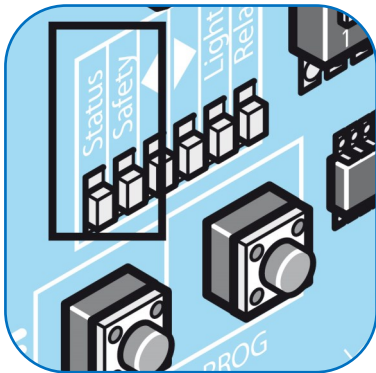

"Safety" LED flashing sequence	Meaning
———— (permanent)	Emergency unlocking, emergency stop or stop button actuated
■ ■ ■ ■ (x2)	Safety contact strip twisted or disconnected
■ ■ ■ ■ ■ ■ (x3)	Passing in front of the cells
■ ■ ■ ■ ■ ■ ■ ■ (x4)	Operating time > 90 seconds, stroke too short or too long
■ ■ ■ ■ ■ ■ ■ ■ ■ (x5)	System Error : The control unit has a fault or the gate is overloaded
"Status" LED flashing sequence	Meaning
———— (permanent)	Installation OK
■ ■ ■ ■ (x4)	Sleep mode is activated
■ ■ ■ ■ (x2)	Gate open, time delay elapses before automatic closing
■ ■ (x1)	Insufficient battery charge

Appendix

Identification and programming of a pair of cells or a flashing light,
(to be carried out only when replacing cells or a light).

1- Identification of the wireless safety cells :

TX : Transmitter cell
(Green LED)

Dipswitches

RX : Receiver cell
(Red LED)

- Toggle dipswitch 1 to ON (on both cells).
- Insert batteries observing correct polarity.
- Permanently install the cells in their locations while checking the alignment.

2- Programming of the cells on the MASTER control board :

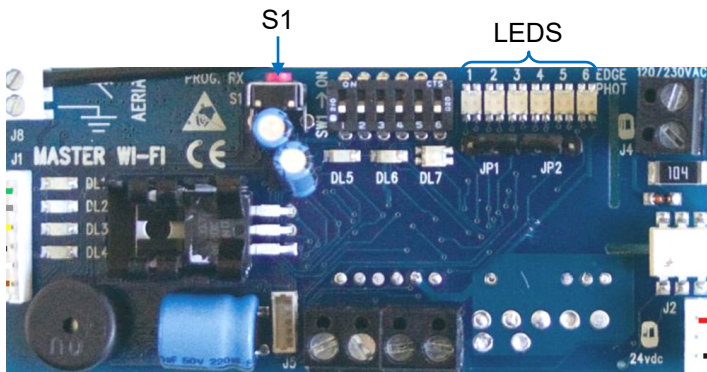

Step 1 : Reset the control board.

- Press and hold the **S1** button until all LEDS light up (≈15 s).
- Release button **S1**, the reset is complete.

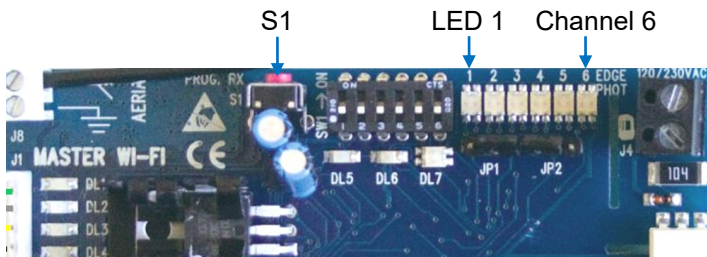

Step 2 : Programming the new cell pair.

- Press button **S1**, **LED 1** flashes red.
- Press the **S3** button on the **RX** cell. When storage is completed, the control board activates its buzzer and the **LED** on cell flashes 3 times to confirm.

RX : Receiver cell
(Red LED)

S3

- The control board stores the channel and automatically switches to the next channel to store another security.
- Please note** : To exit programming, press as many times as necessary to scroll through the flashing **LEDS** to the 6th channel, then press button **S1** one last time, all **LEDS** will go out.

LED status information :

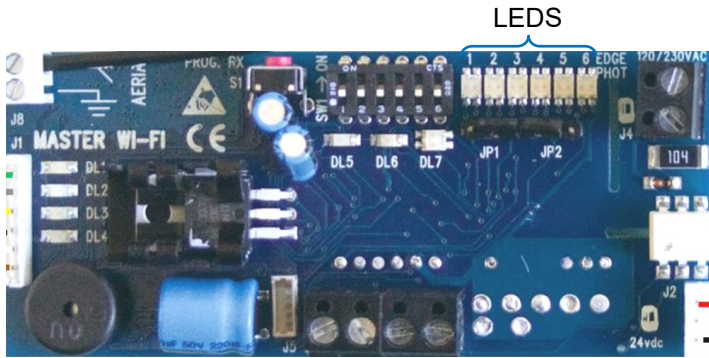

MASTER control board

Off = Proper operation

Green = Safety sensing device

Flashing red/green = Battery alarm unloaded

3- Programming the flashing light :



Flashing light

Step 1 : Flashing light power supply.

- Insert the 3 batteries Type C - LR14 / 1,5V into the flashing light respecting the polarities.

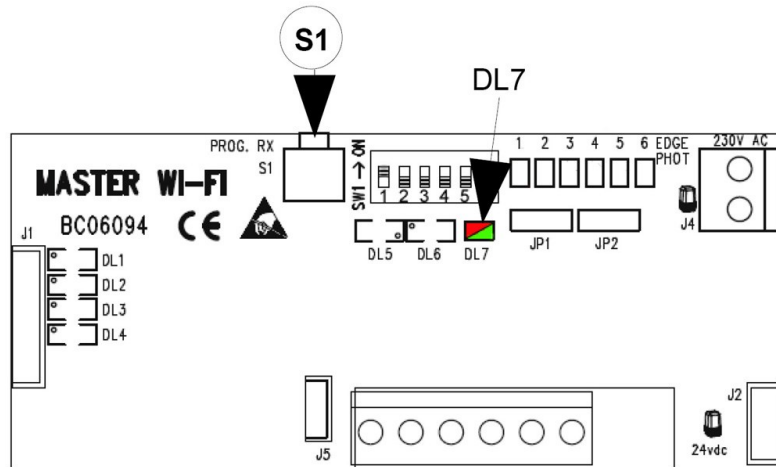

MASTER control board

Step 2 : Programming the flashing light on the MASTER board.

- Hold down button **S1** for 3 s, then release, **LED DL7** on the control board flashes red.

- Press the **S4** button on the flashing light board.

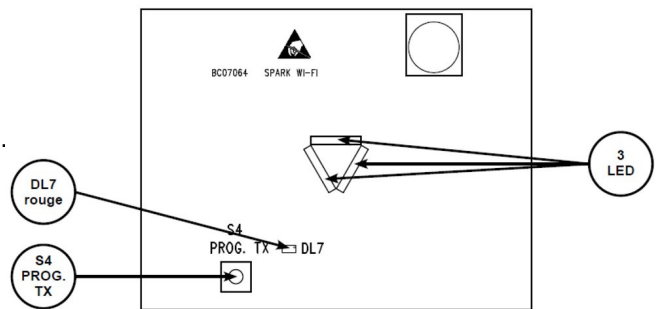

Flashing light board

- When the storage is done, the management board activates its buzzer and the two-color **DL7 LED** lights green. **LED DL7** on the flashing light board, flashes 3 times to confirm.

- To exit from programming, wait 10 s or briefly press button **S1** on the control board.

In the case of an openwork gate

Post housing the Totem operator

