

Manual: No. 7389 **INSTALLATION**

Sliding Gate

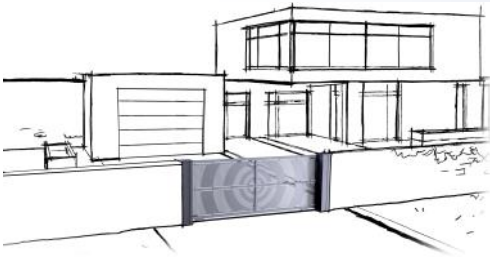

Self-supported

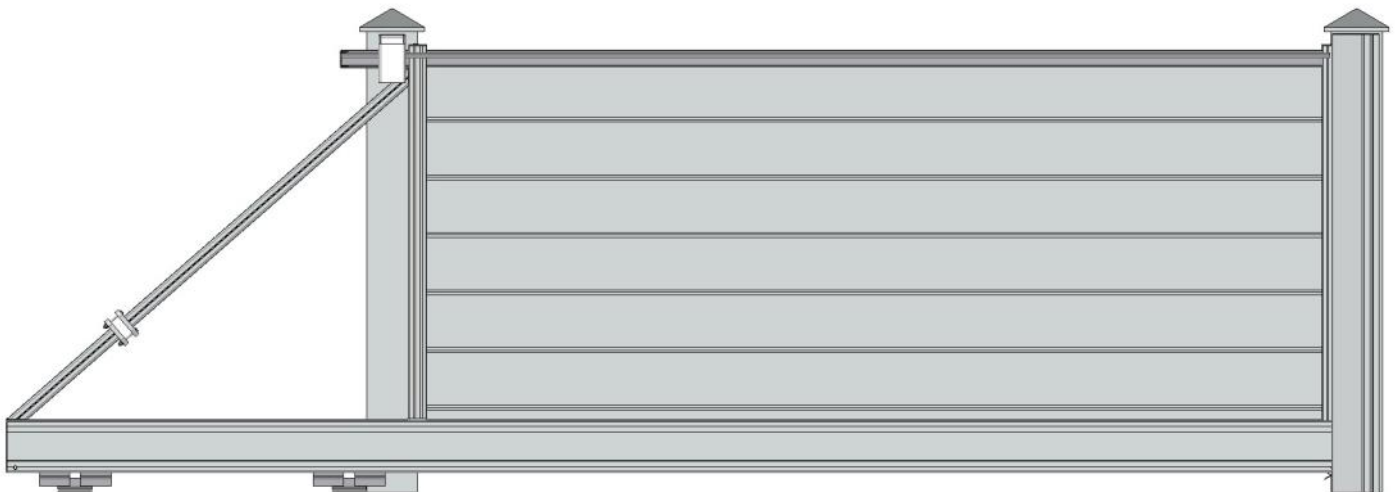

(Document reserved for installers)

Contents

Required equipment	p.2
Installation instructions	p.3
Concrete work	p.4 to p.5
- Top view	p.4
- Front view	p.4
- Perspective view	p.5
Markings.....	p.5 to p.6
- Bearing plate center distance (top view).....	p.5
- Operator support (front view).....	p.6
- Sheathing (top view).....	p.6
Install the beam	p.7
- Level	p.7
- Alignment (top view)	p.7
Install the top guiding rail.....	p.8
Install the gate.....	p.8 to p.11
- Insert the PVC guides	p.8
- Insert the gate.....	p.9
- Move the gate	p.9
- Attach the gate to the beam	p.10
- Attach the opening stop	p.10
- Tighten the tensioner (gate closed).....	p.11
Install the strike jamb.....	p.12 to p.16
- Attach the bracket stop	p.12
- Attach the U-section.....	p.13
- Attach the beam support	p.14
- Attach the centralizing guides	p.15
- Manual gate only (strike plate and buffer).....	p.16
Assembling the weather seal	p.16
Motorization.....	p.17 to p.19
- Install the passive safety edge	p.17
- Install the operator support.....	p.18
- Install the rack and pinion.....	p.19
Finishes	p.19
Electric closing	p.20 to p.27
- Cable pulling diagram.....	p.20
-Fit the operator.....	p.20
- Set the limit-switches	p.21
- Operator wiring.....	p.23
- Programming the operator	p.23
- Advanced programming of the operator.....	p.25
- Install the Battery Kit	p.26
- Error table	p.27

Required equipment

- | | |
|-------------------------------|--|
| - Trestles | - Set of steel/concrete drill bits |
| - Cloth | - Hammer/chisel |
| - Spirit level or laser level | - Appropriate screws and pins for the support |
| - Plumb bob | - Electric Screwdriver with end-pieces |
| - Tape measure (8M) | - Flat wrenches / Socket wrenches / Allen keys |
| - Brush + Universal grease | - 90 mm high shims |
| - Hammer drill | - Angle grinder |

Installation instructions

CAUTION!



To ensure that this product is assembled, used and maintained in complete safety, it is important to follow the instructions provided in this document. For everyone's safety, please observe the precautionary measures below.



- * Before beginning the assembly, read this manual carefully.
- * This closure must be installed by a professional technician.
- * All the parts delivered are specifically sized for this product. Adding and/or using other parts may be detrimental to safety and may affect the product's warranty.
- * Any modification or improvement of this closure must be compliant with the standard EN 13241 + A2. In this case, a "modification/transformation" file must be created by the installer as per the standard EN 12635 annex C.
- * Use the appropriate tools to install these products.
- * Ensure that the assembly area is clear, clean and clearly marked out.
- * Ensure that no other people are present at the assembly site apart from the installers. Non-authorized persons (children for example!) who are present at the site risk injury during assembly.
- * All the components of this closure must be installed in compliance with the installation instructions provided in this manual.
- * **All the requirements of the standards EN 13241 + A2 must be met and verified if necessary.**

Max. locking torque:

- Assembly screw: **10 Nm**

Concrete work

Please note: The opening is always shown from the external view.

Top view

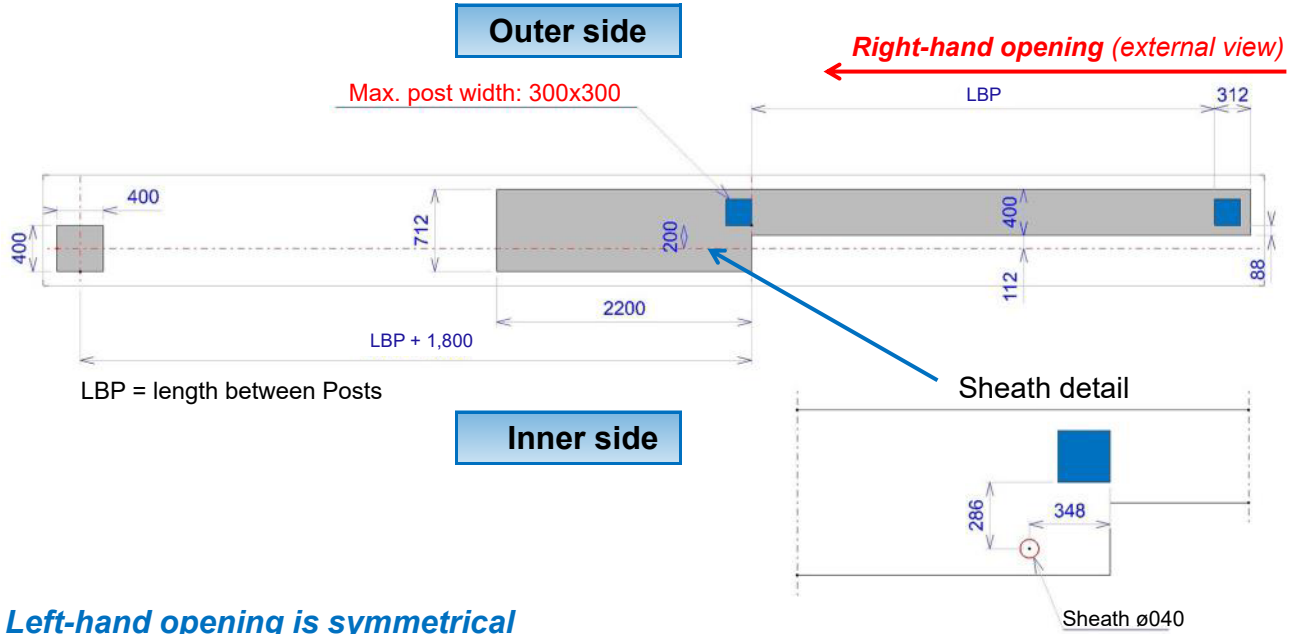

Front view

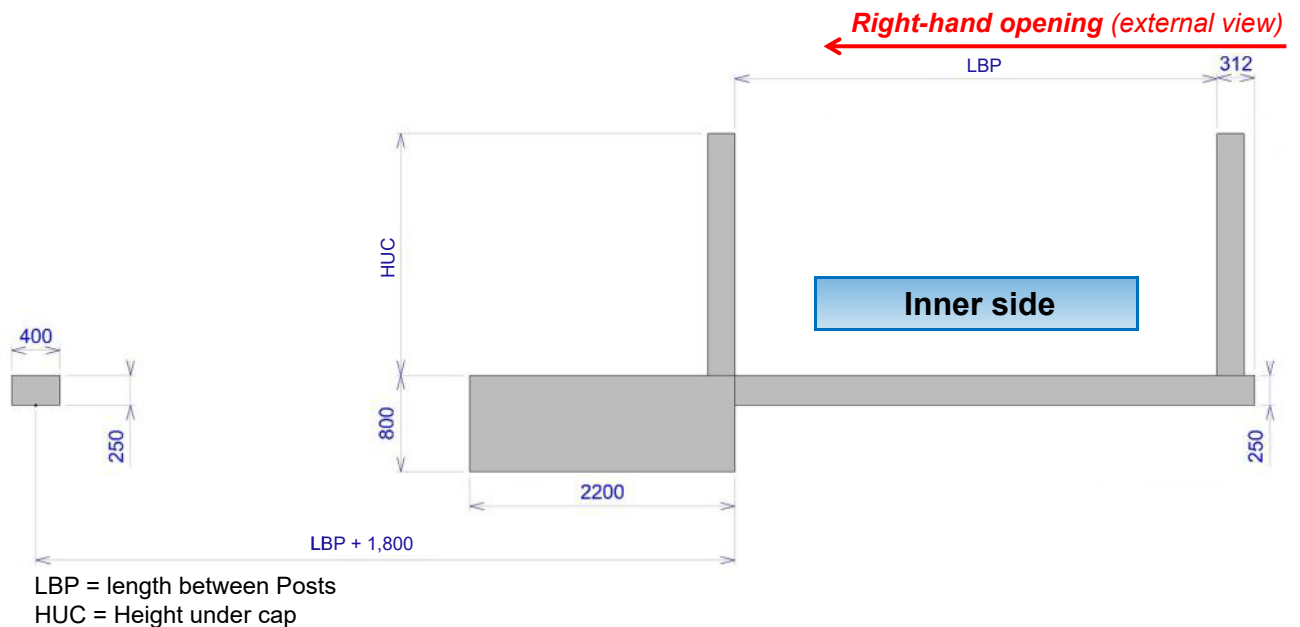

Perspective view

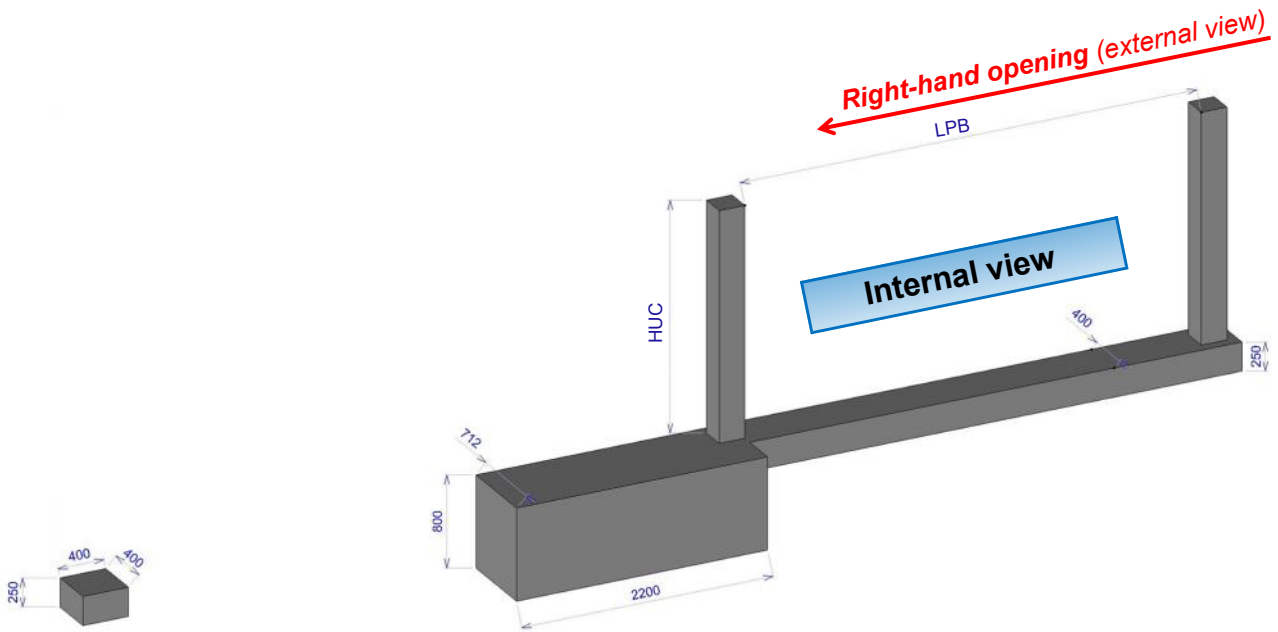

LBP = Length between Posts
HUC = Height under cap

Left-hand opening is symmetrical

Markings

Bearing plate center distance (top view)

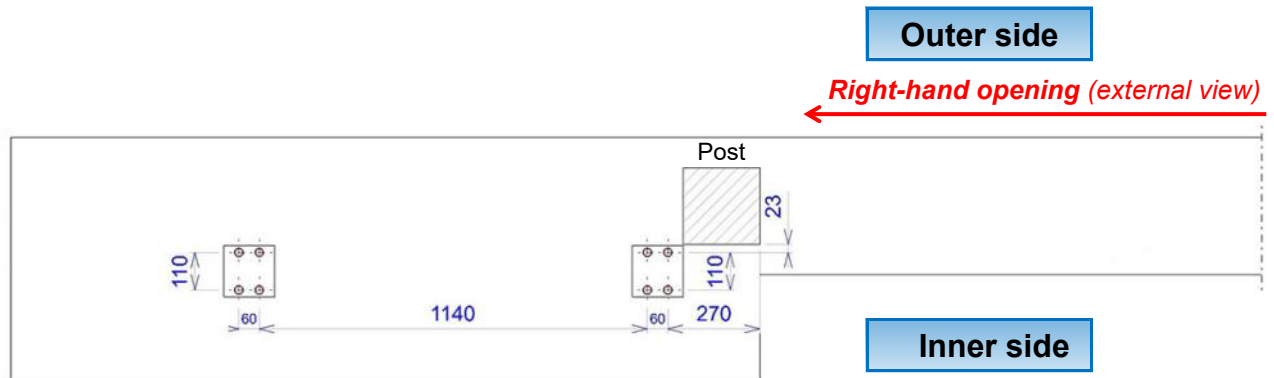
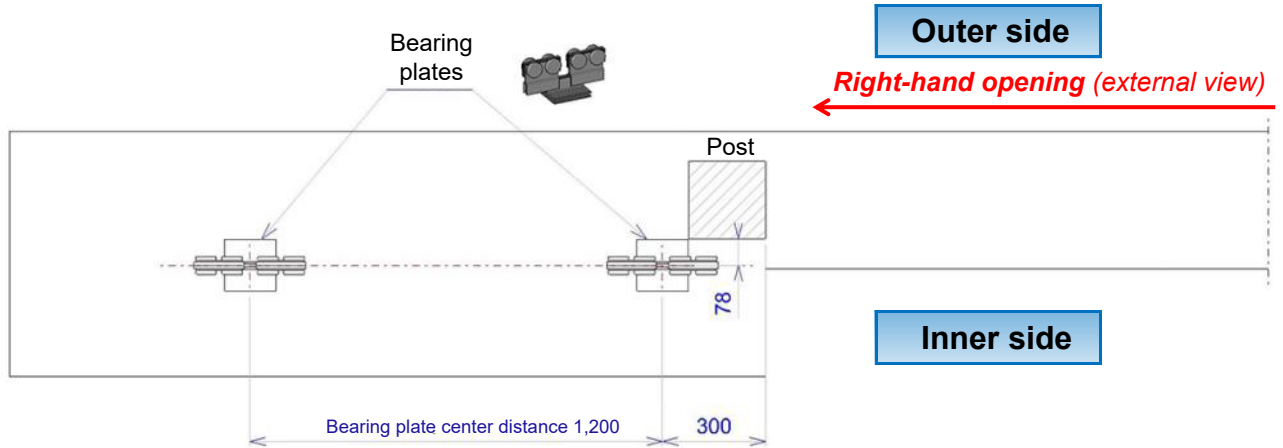

Left-hand opening is symmetrical

Operator support (front view)

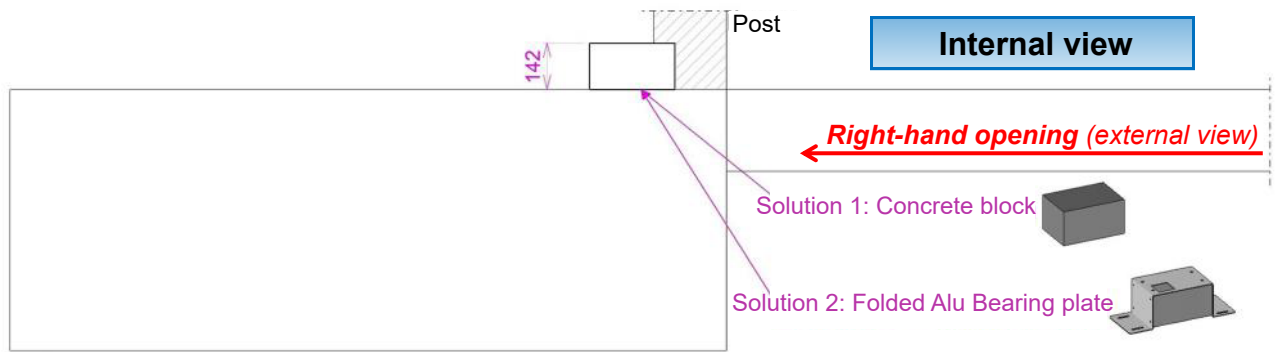

Left-hand opening is symmetrical

Sheathing (top view)

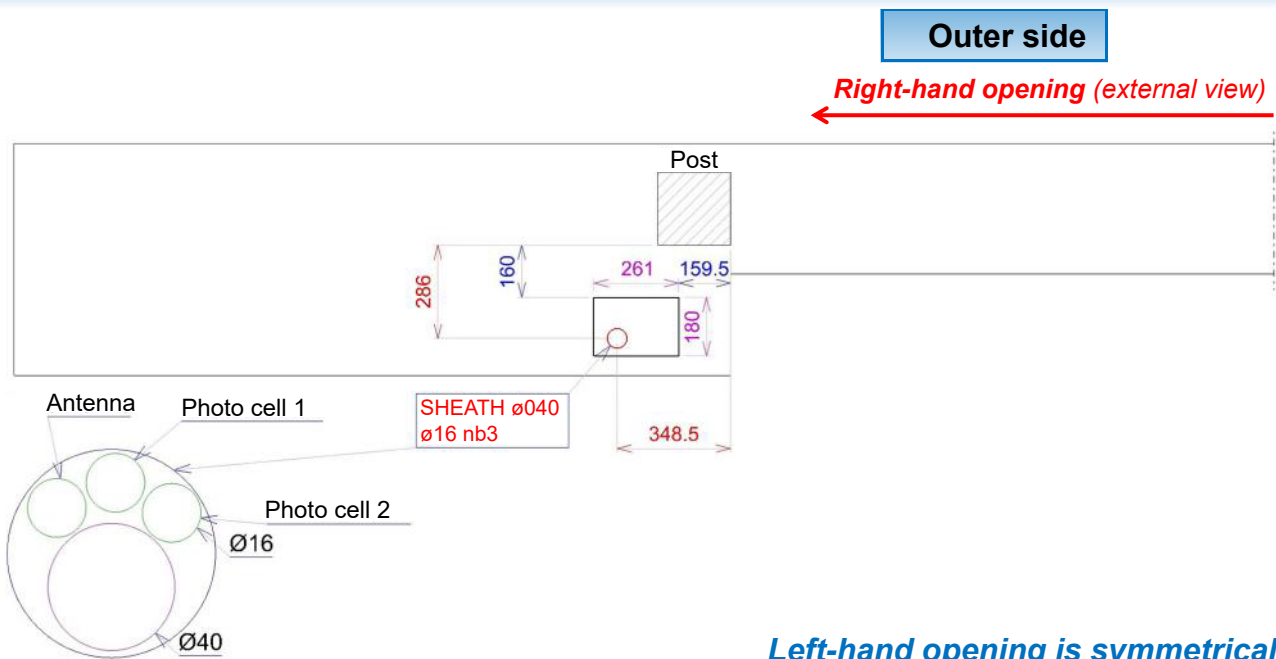

Left-hand opening is symmetrical

Install the beam

Level

Please note: For motorized gates, check that the drill holes for the invisible rack and pinion are on the inner side.

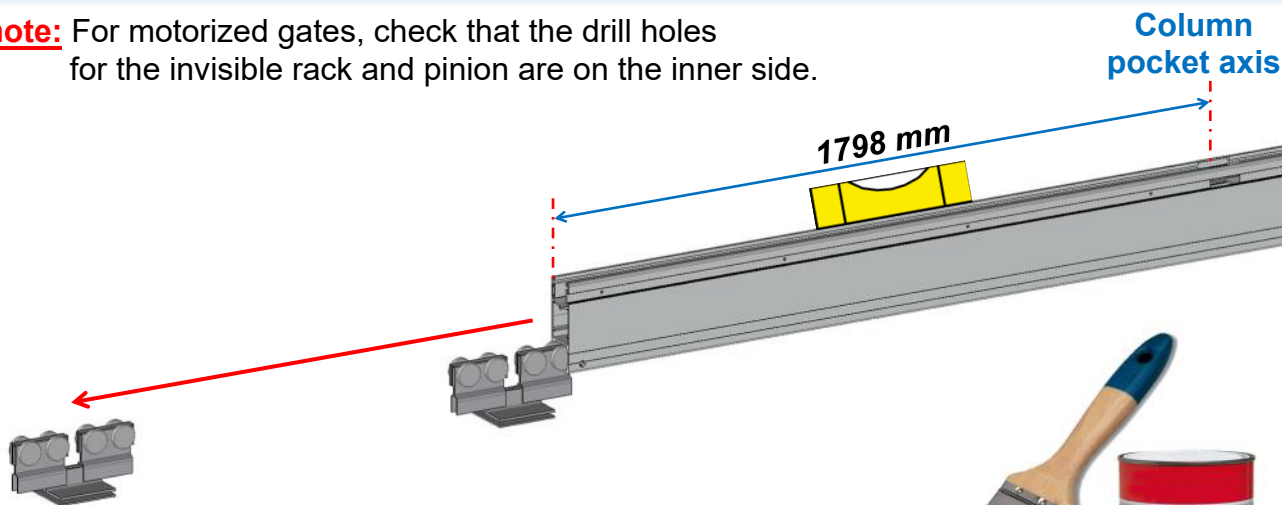

Grease before installation



Adjust the level by tightening the end screws (slightly loosen the screws at the center).

Tip: tilt the beam upwards slightly on the closing side (because it will be supporting the weight of the gate). After adjustment, pre-tighten the screws in the center.

Alignment (top view)

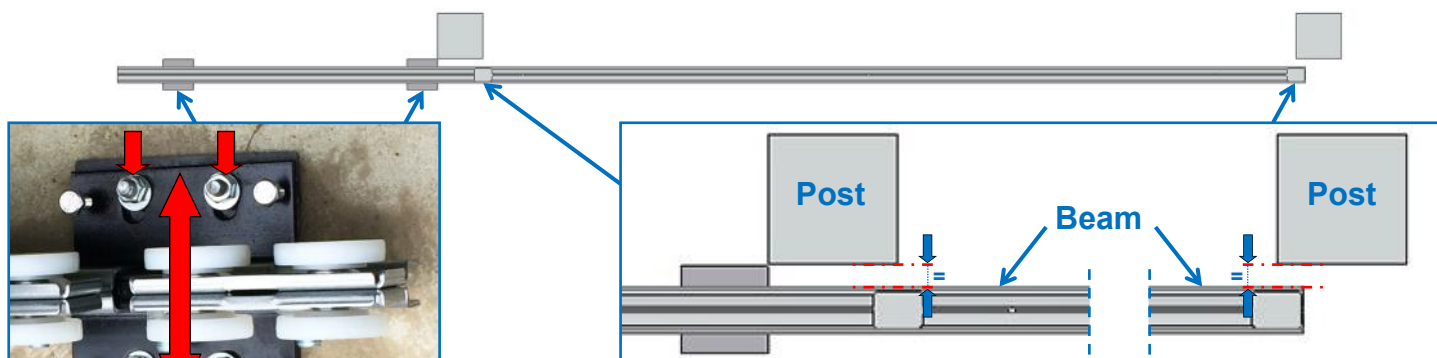

Distance between posts / beam

The beam must be aligned with the posts.
The distance between each of them must be the same.
If it needs to be adjusted, loosen the fittings in the center and adjust the plate using the oblong holes, then firmly tighten the screws.

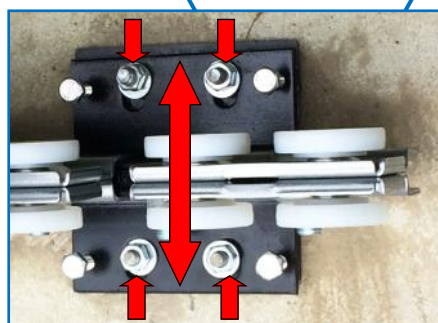

Fittings

Install the top guiding rail

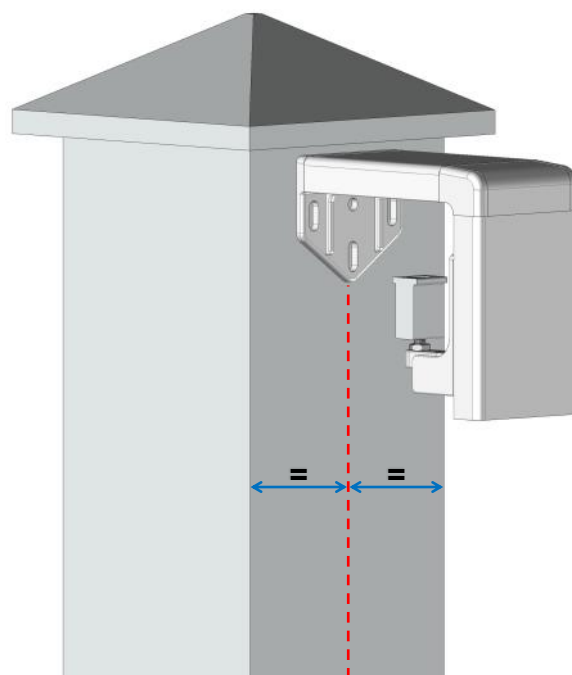
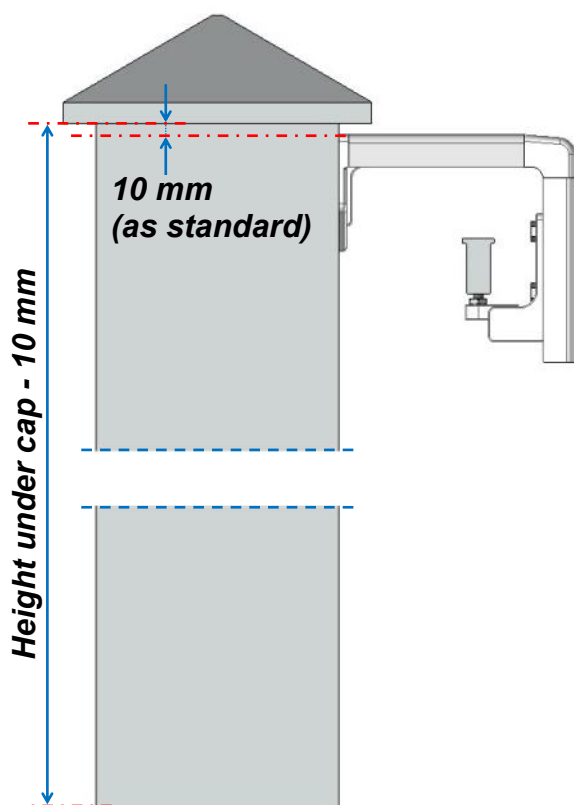

When attaching the top guiding rail to the post, provisionally secure the screws without fully tightening them.

Please note:

If using aluminum posts 224 mm to be affixed with screws:

- Secure the screws TH M8x25 with the mounting plate 76x55x5 M8.

If using aluminum posts 224 mm to be sealed:

- Secure the screws TH M8x20 and the gibs 25x20x5 M8.

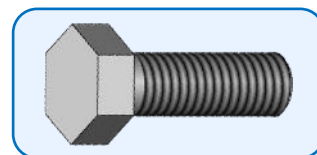

Install the gate

Insert the PVC guides

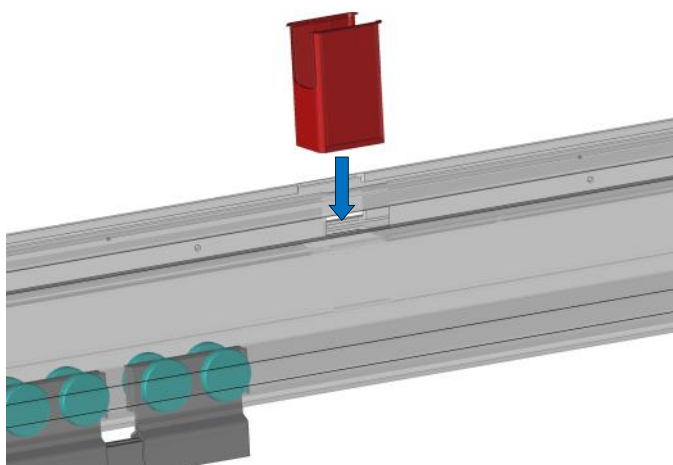

Place the beam in full opening position. Insert the PVC guides into the pockets of the beam.

Insert the gate

Insert the gate columns into the beam.

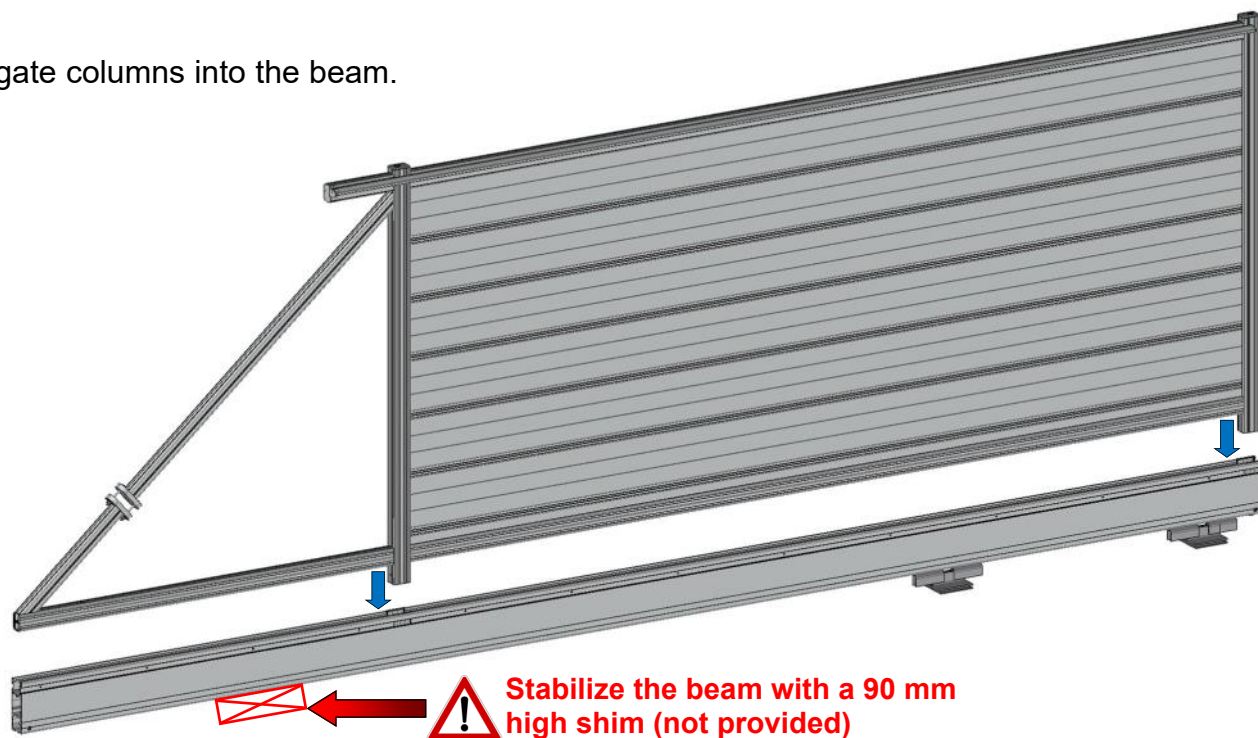

Move the gate



Slide the gate into the top guiding rail, then adjust and fully tighten all the screws of the guiding rail.

Attach the gate to the beam



Screws: TH M6x65 + Washers M6 + Nut M6

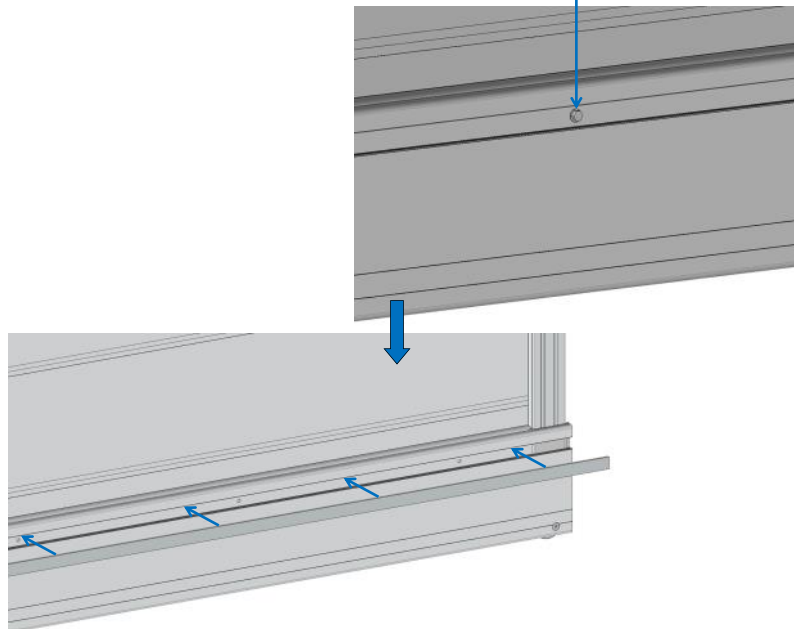

Adjust the gate so that it is plumb.

Along the entire length of the beam, drill holes in the bottom transom using the guide holes on the beam, then tighten the assembly with the bolts above, adding a washer on each side.
To finish, add the clips to the beam on the inner and outer sides.

Attach the opening stop

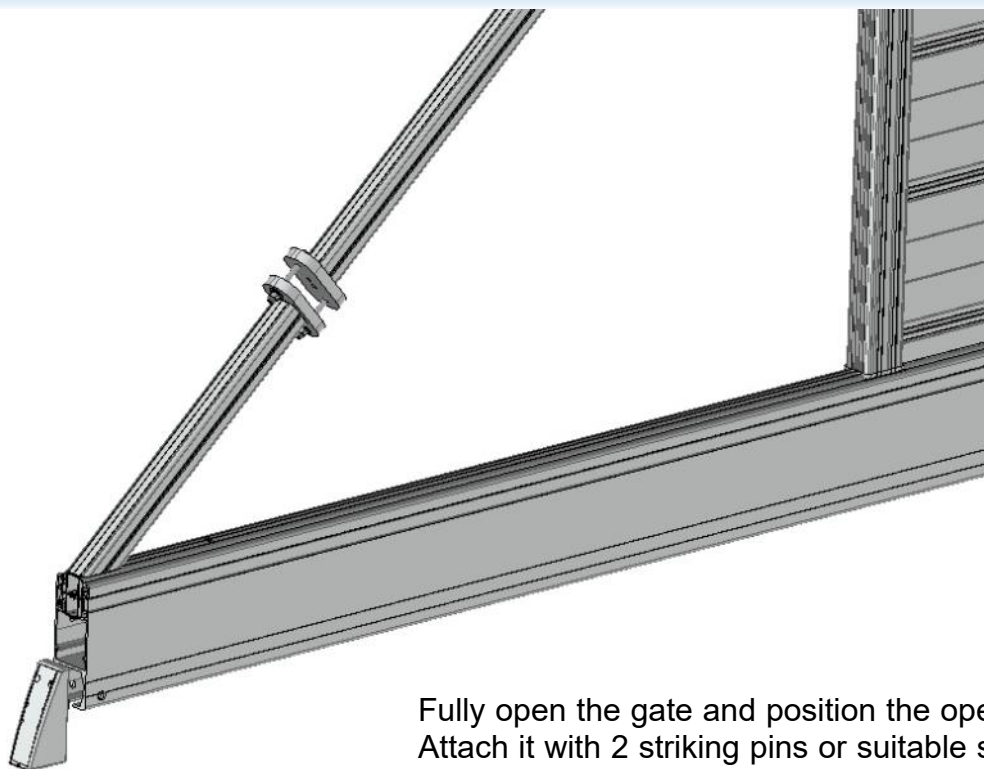

Fully open the gate and position the opening stop on the floor.
Attach it with 2 striking pins or suitable screws (not provided).

Tighten the tensioner (gate closed)

Adjust the tension of the gate, tightening it but not fully:



Screws: TH M10x100 + Nuts M10
+ Cap nuts M10

After adjustment, cut the screws and add the cap screws.

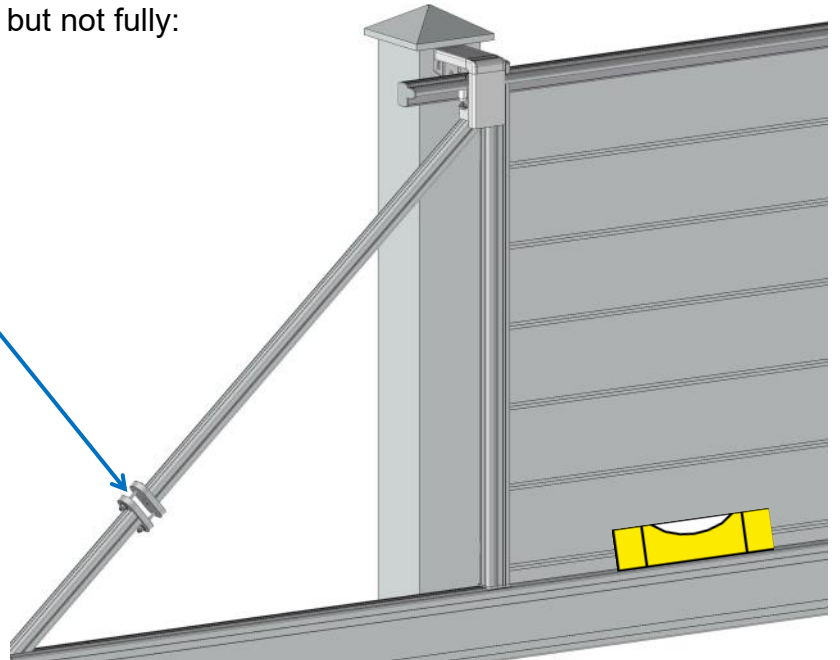

Please note:

To slightly adjust the level of the gate, tighten or loosen the screws on the fittings.

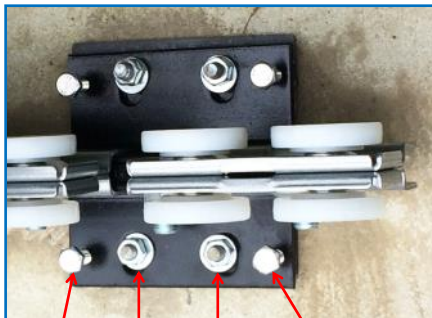

Unscrew

Adjustment screw

Install the strike jamb

Attach the bracket stop

Place the bracket stop on the floor against the concrete post, in accordance with the dimensions of the drill holes.

Please note: For aluminum posts:

- To be sealed: Screws TH M8x20
+ Gibs 25x20x5 M8 (provided)

- To be affixed with screws: Screws TH M8x25 + Mounting plates 76x55x5 M8 (provided)

114.5 mm

To be affixed to all the attachment points

Adapt the fittings (not provided) according to the support

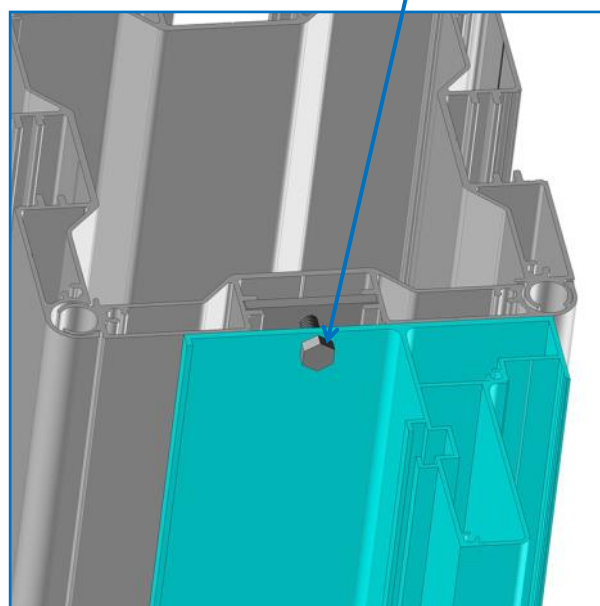
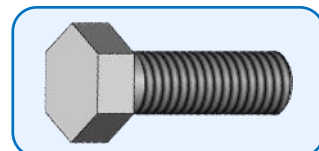

To be clipped onto the bracket stop

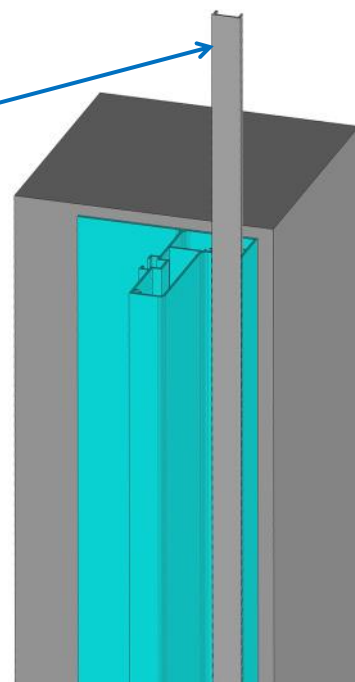

Attach the U-section

- Insert the screws into the U-section:

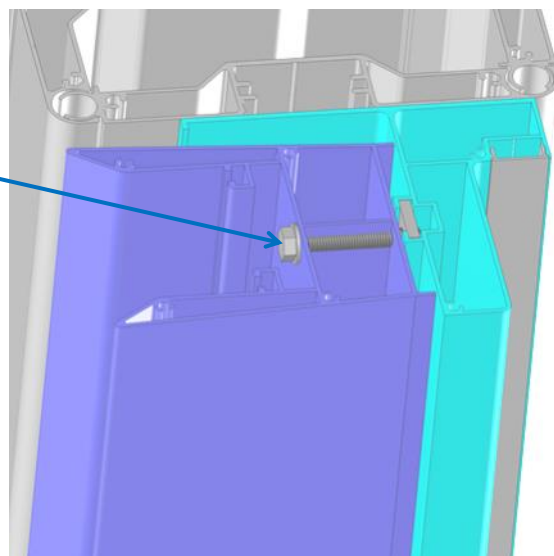
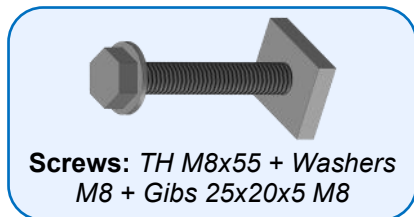

- Slide the assembly into the bracket stop from the top.

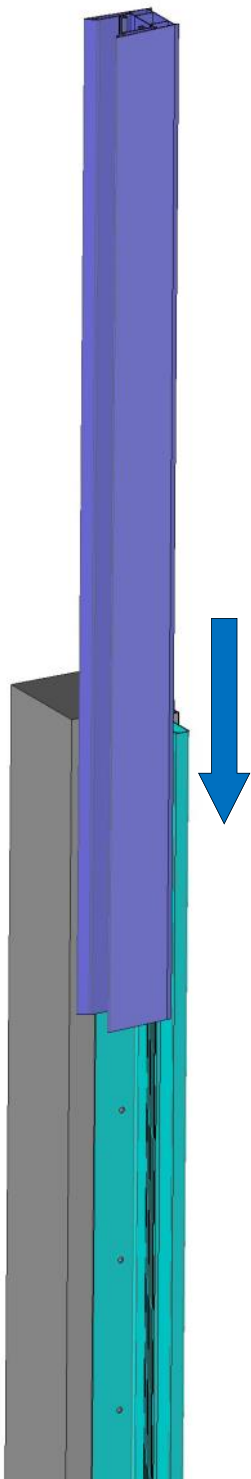

- Position the gate against the U-section.
- Adjust the section horizontally in relation to the gate and so that it is plumb, then tighten the screws.

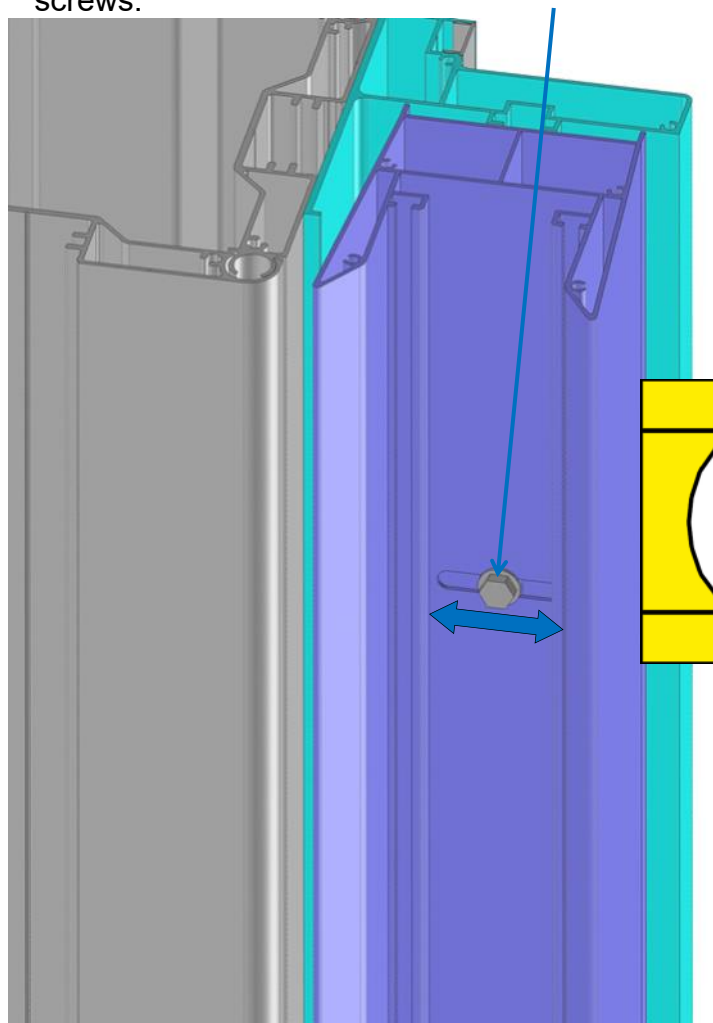

Attach the beam support

- Insert the screws into the bottom support:

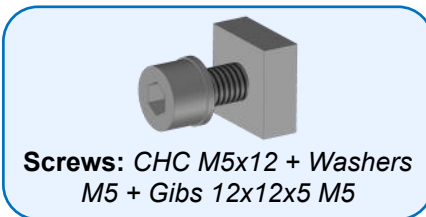

- Slide the assembly into the U-section from the top.
- Position the gate against the U-section.
- Adjust the height of the bottom support:
The roller located under the gate beam must rest lightly on the support, during closing.

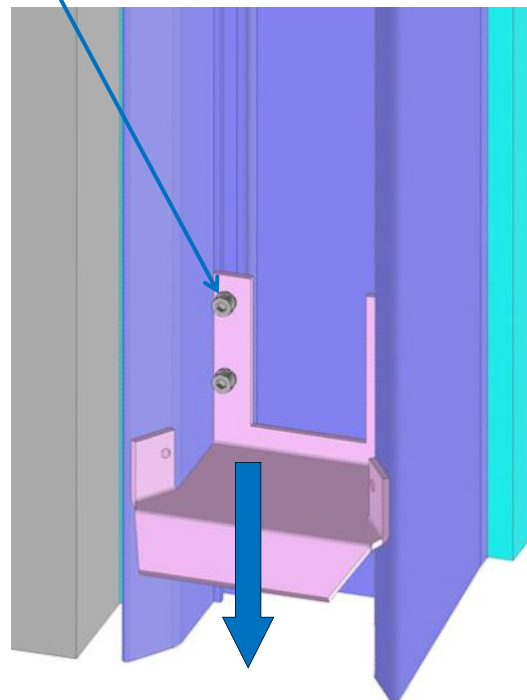
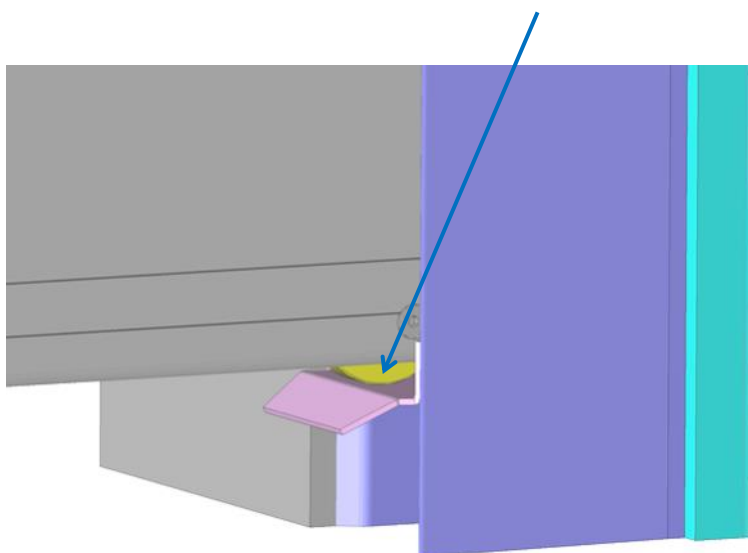

- Tighten the screws CHC M5x12

- Lock the support in place

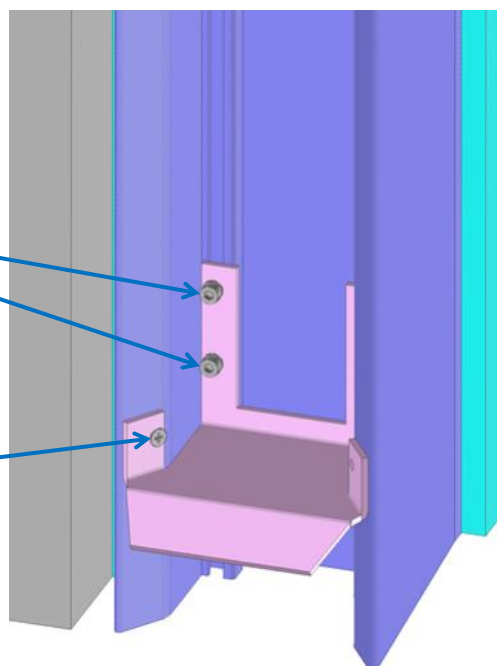

Attach the centralizing guides

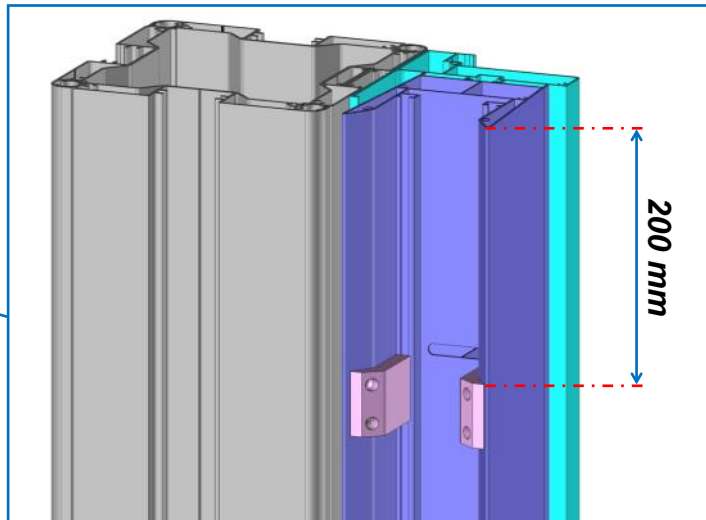
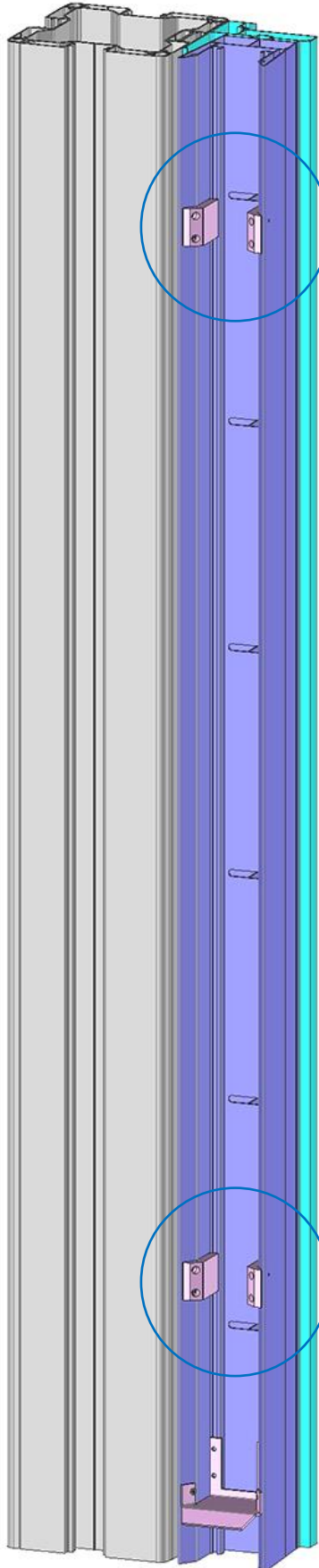

- Position the 1st pair of centralizing guides on the inside and at 200 mm from the top of the U-section.

- Attach the guides.

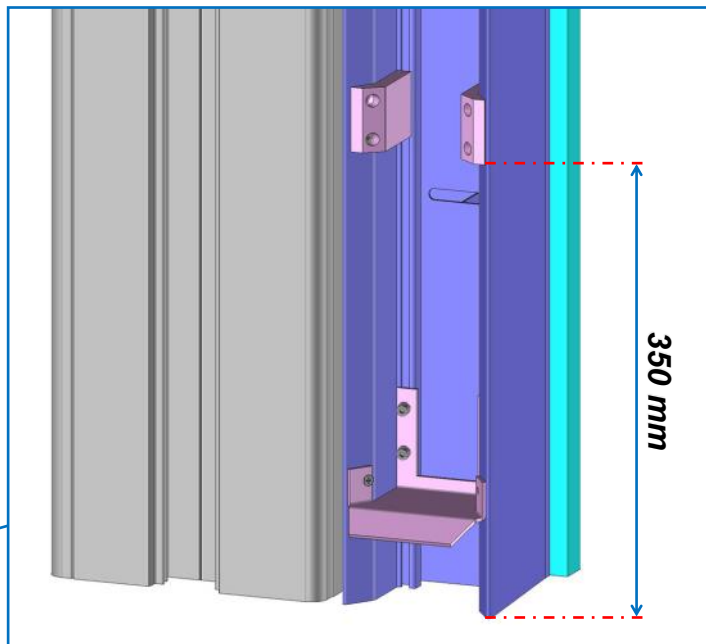

- Position the 2nd pair of centralizing guides on the inside and at 350 mm from the bottom of the U-section.

- Attach the guides.



Manual gate only (strike plate and buffer)

- Insert the screws into the buffer plate and the Stainless steel strike plate :

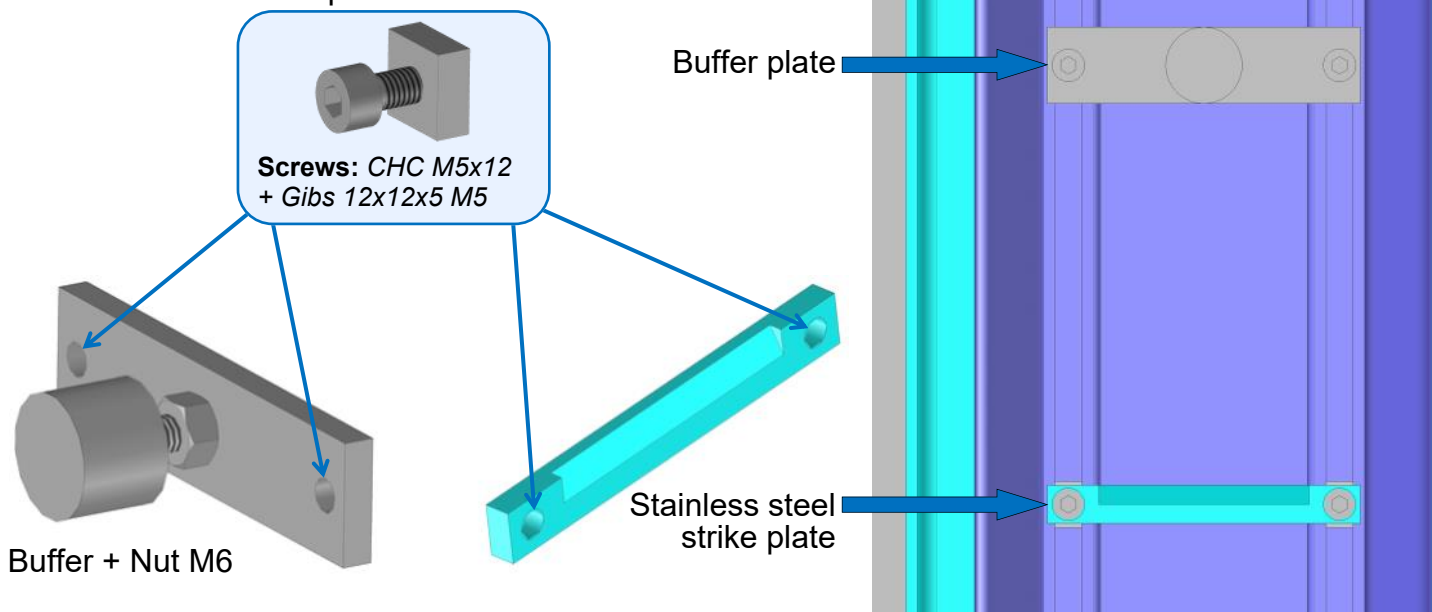

- Slide the assembled buffer plate and Stainless steel strike plate into the U-section from the top.
- Measure the height of the hook on the gate lock so that the strike plate can be positioned.
- Position the buffer above the strike plate, tighten the screws CHC M5x12 of the Stainless steel strike plate and the buffer plate.

Assemble the weather seal

- Clean off all the dust and moisture from the exterior surface of the gate where the weather seal will be attached.
- Remove the protective film of the adhesive and place it against the column.
- Stick the weather seal section to the adhesive and press it down firmly.
- Slide the brush onto the inside of the section.



Motorization

Install the passive safety edge



Attach the C-shaped rail to the column



Screws: *Self-drilling*
TF 4.2x16

Please note: For openwork gates:
Add two passive safety edges to the
post on the opening side.

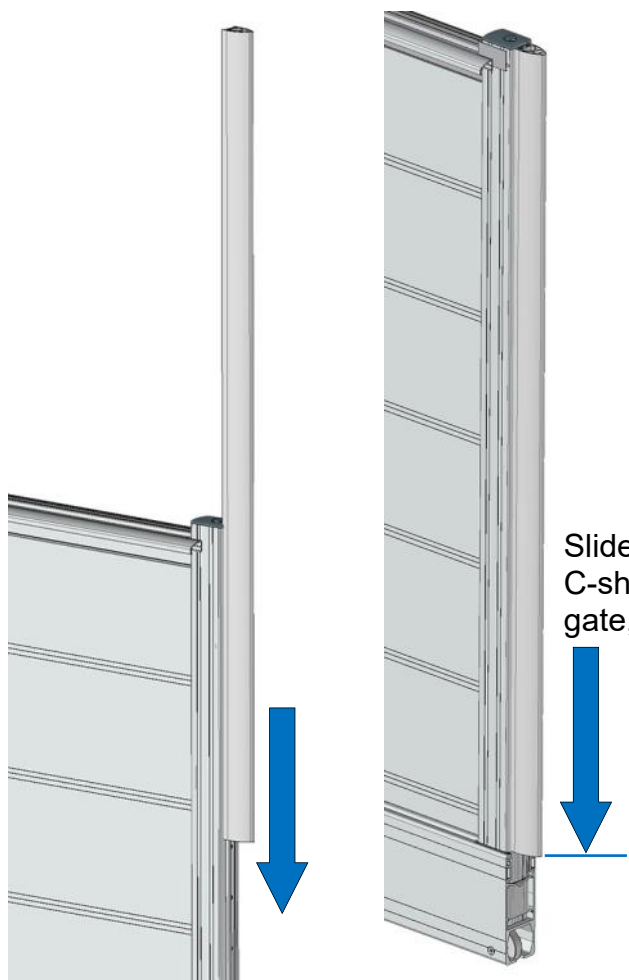
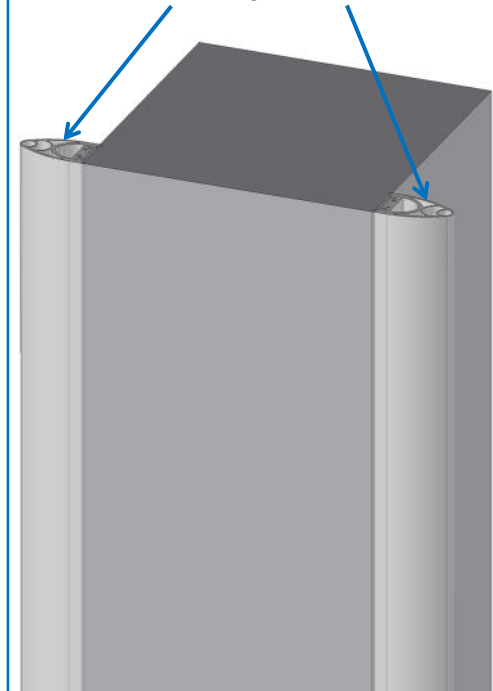

Slide the passive safety edge into the
C-shaped rail, from the top of the
gate, up to the beam.

Install the operator support

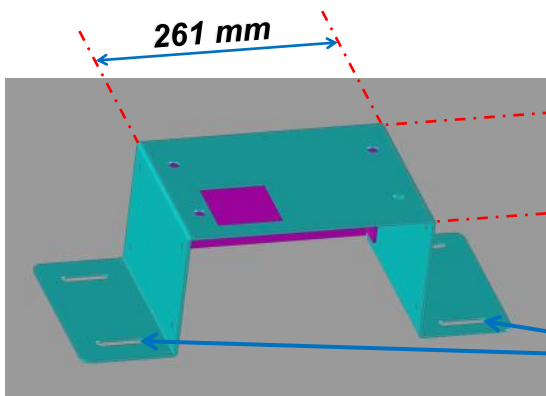
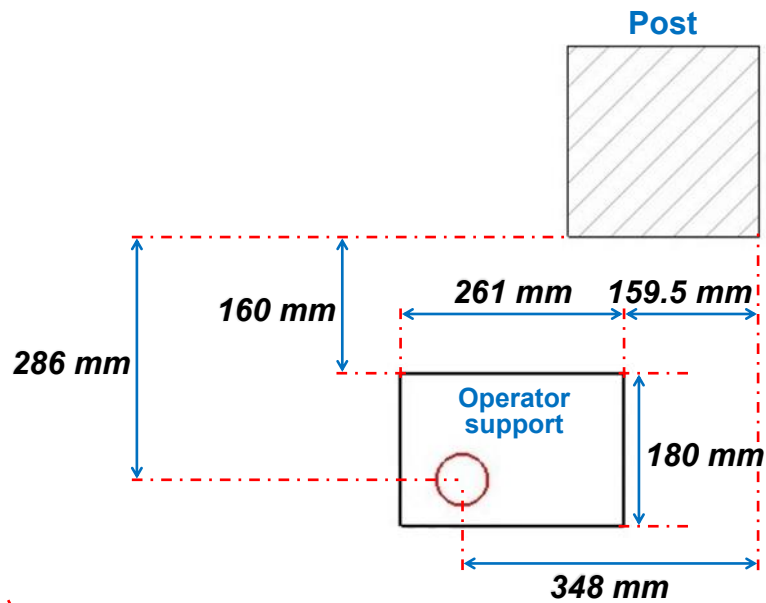

Attach the operator support to the floor, in accordance with the dimensions.

Adapt the fittings (not provided) according to the support

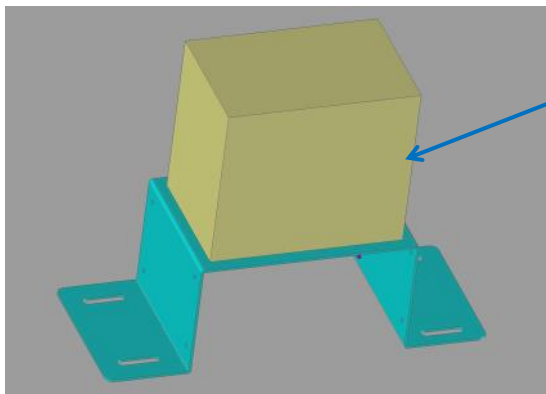

Position the operator on the support. Attach it with:

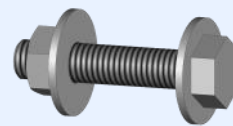

Screws: TH M10x50 + Washers M10 + Nuts M10

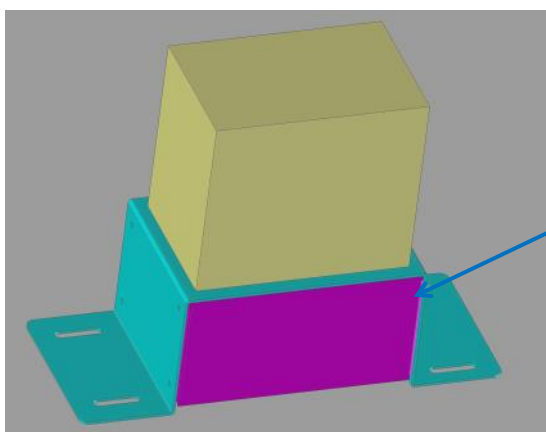

Attach the cover with:

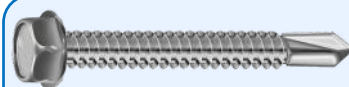

Screws: Self-drilling TH 6.3x25

Install the rack and pinion

- On the inside, position the rack and pinion on the guide holes, in accordance with the dimension of 90 mm from the edge.
- Adjust the height of the rack and pinion in relation to the operator.
- Attach the rack and pinion.

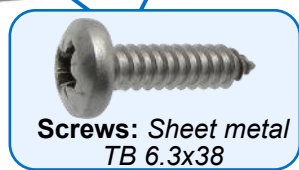
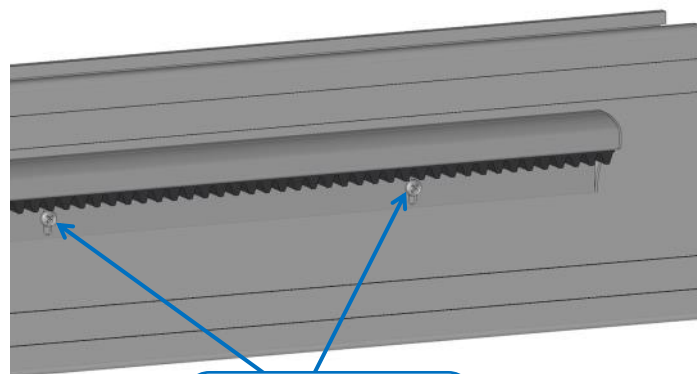
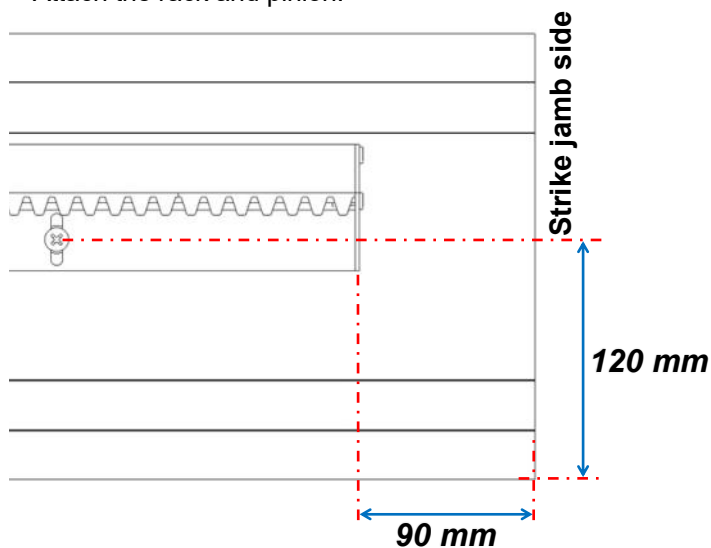

Finishes

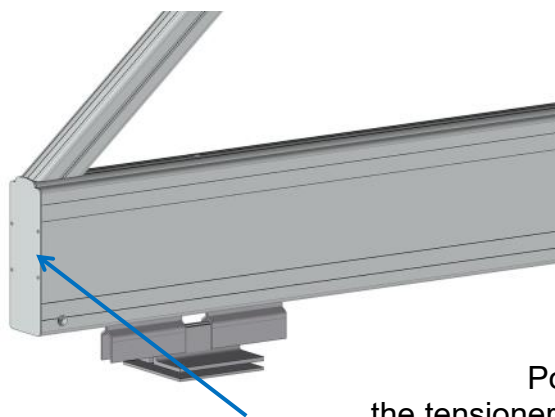

Position the plugs on the tensioner side and the strike jamb side.

Attach them with:

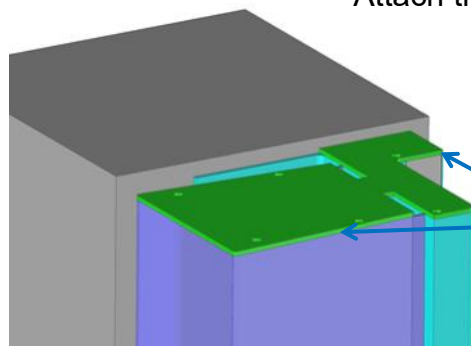

Position the caps on the bracket stop and the U-section.
Attach them with:

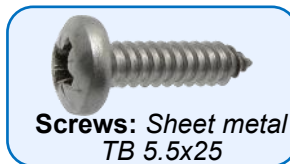

Once the installation is finished, check the following points:

- Check that the entire gate assembly is level and plumb; Check that the beam is aligned.
- Check that the gate opens and closes correctly.
- Check that the gate fits into the U-section properly during closing;
The roller located under the gate beam must rest lightly on the bottom support.

Electric closing

Position the operator and check that the gate closes correctly

Please note: Gate slows down before the stop.

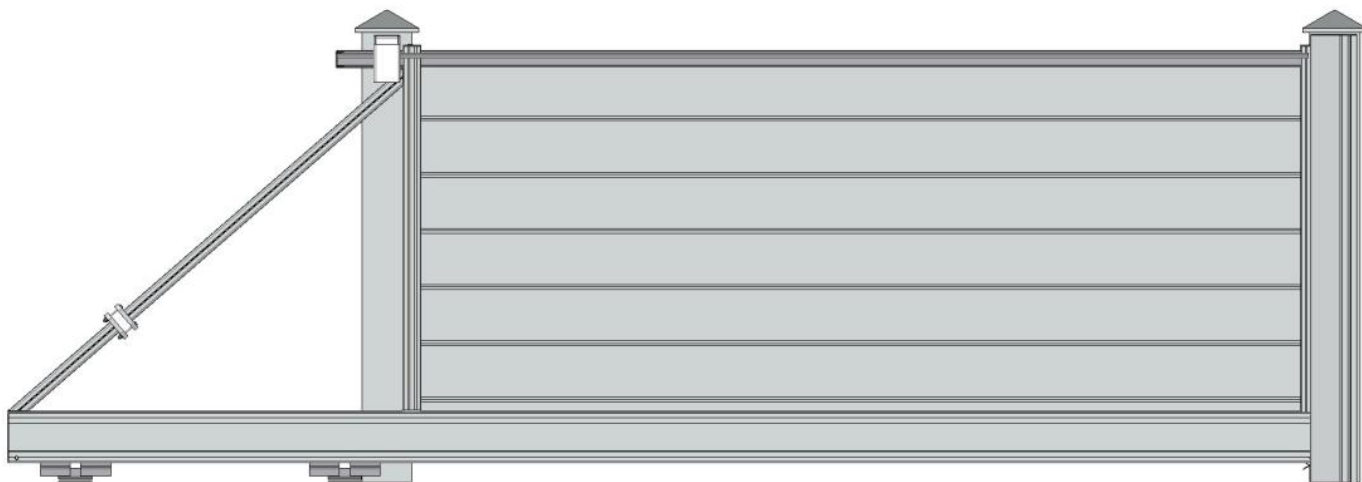

1- Cable pulling diagram

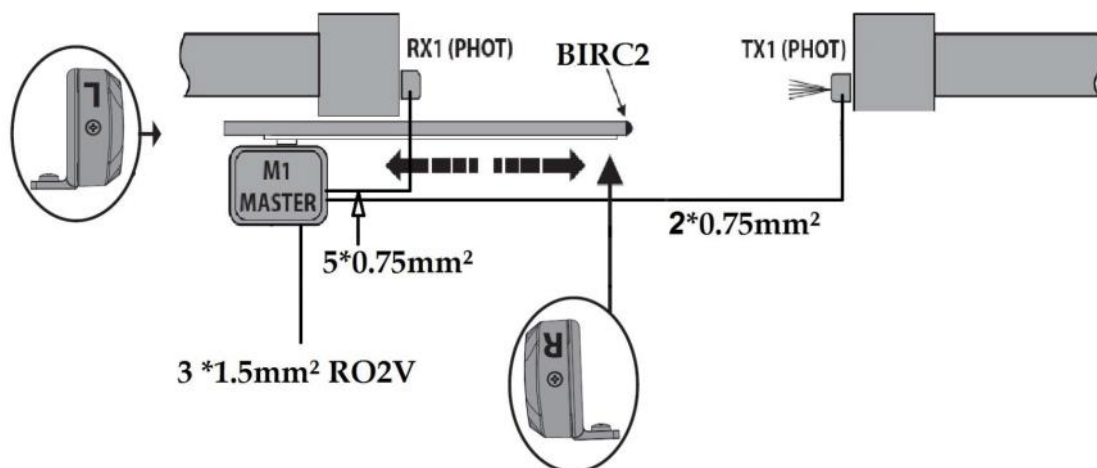

2- Fit the operator

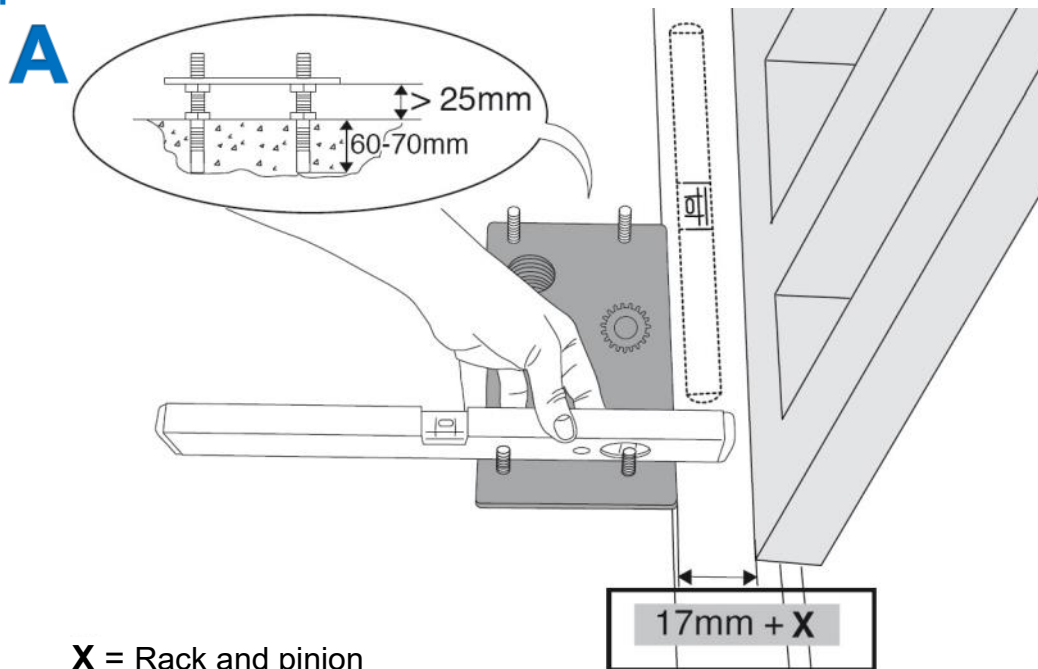

X = Rack and pinion

B



Pinion/rack and pinion clearance

2 mm

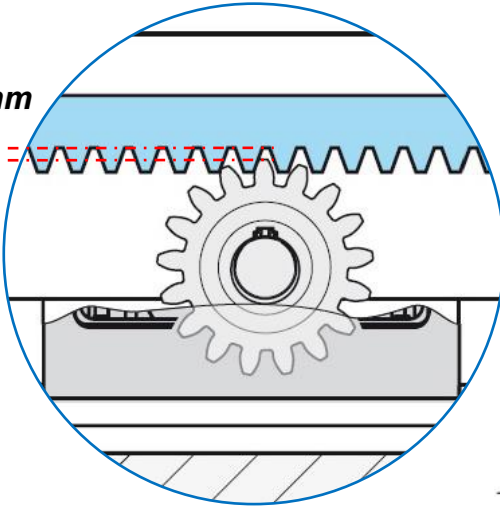

Solid concrete

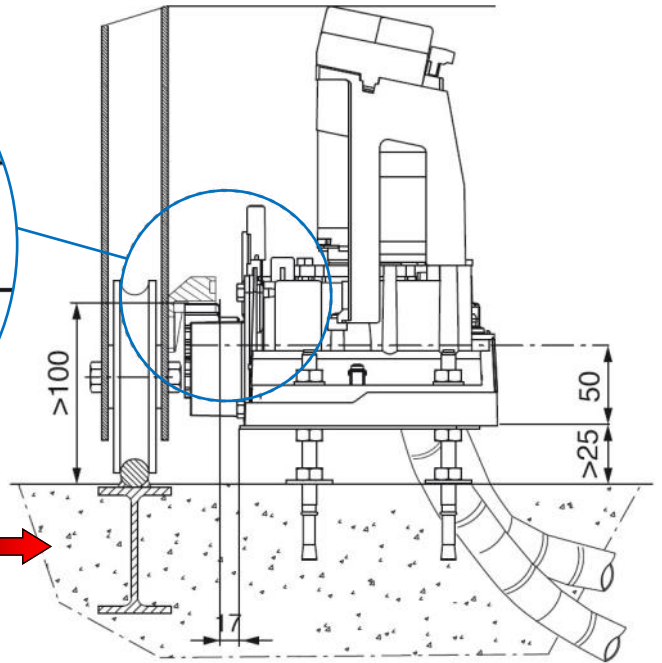

3- Set the limit-switches

C

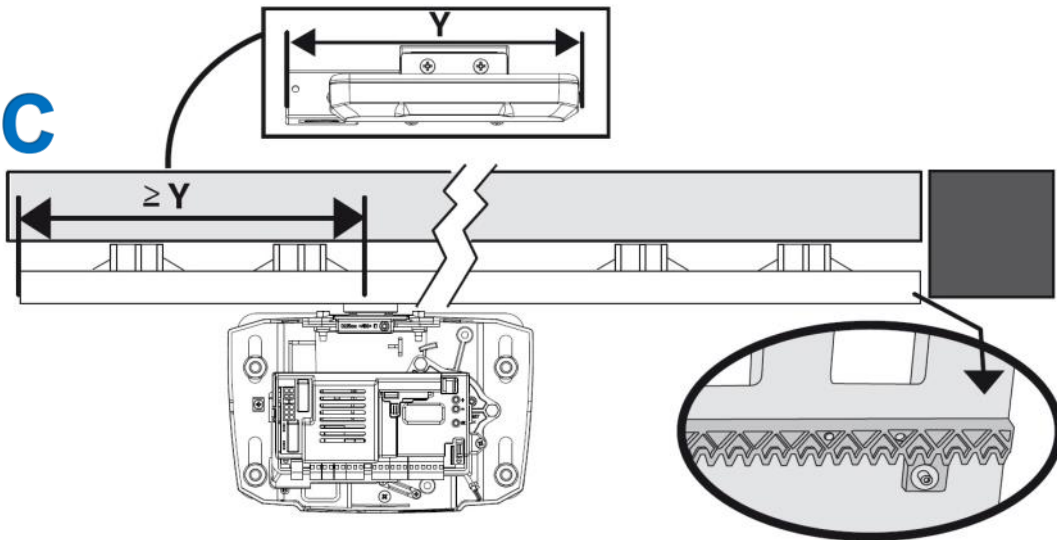

D

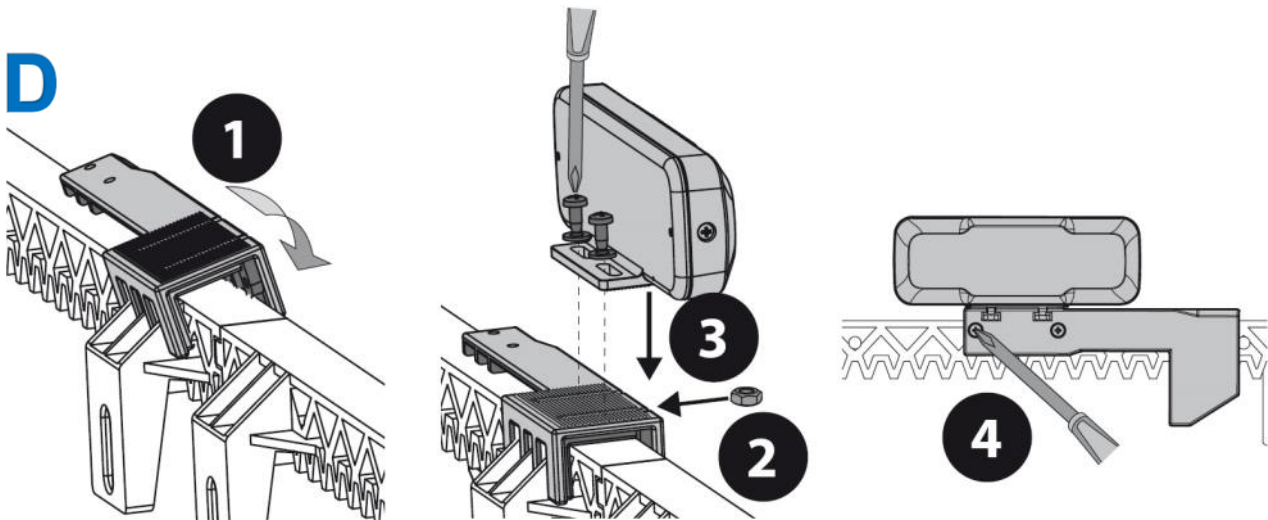

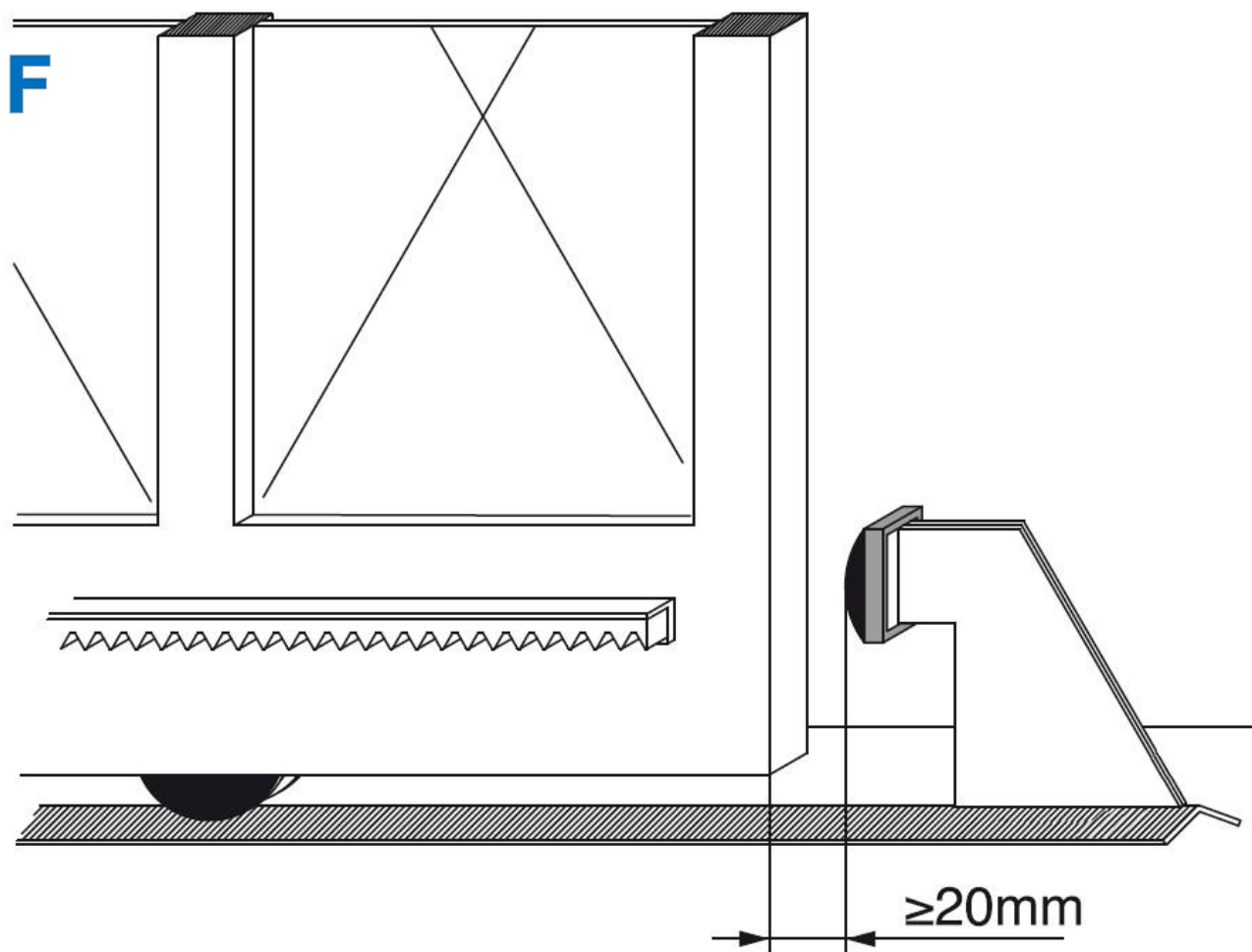
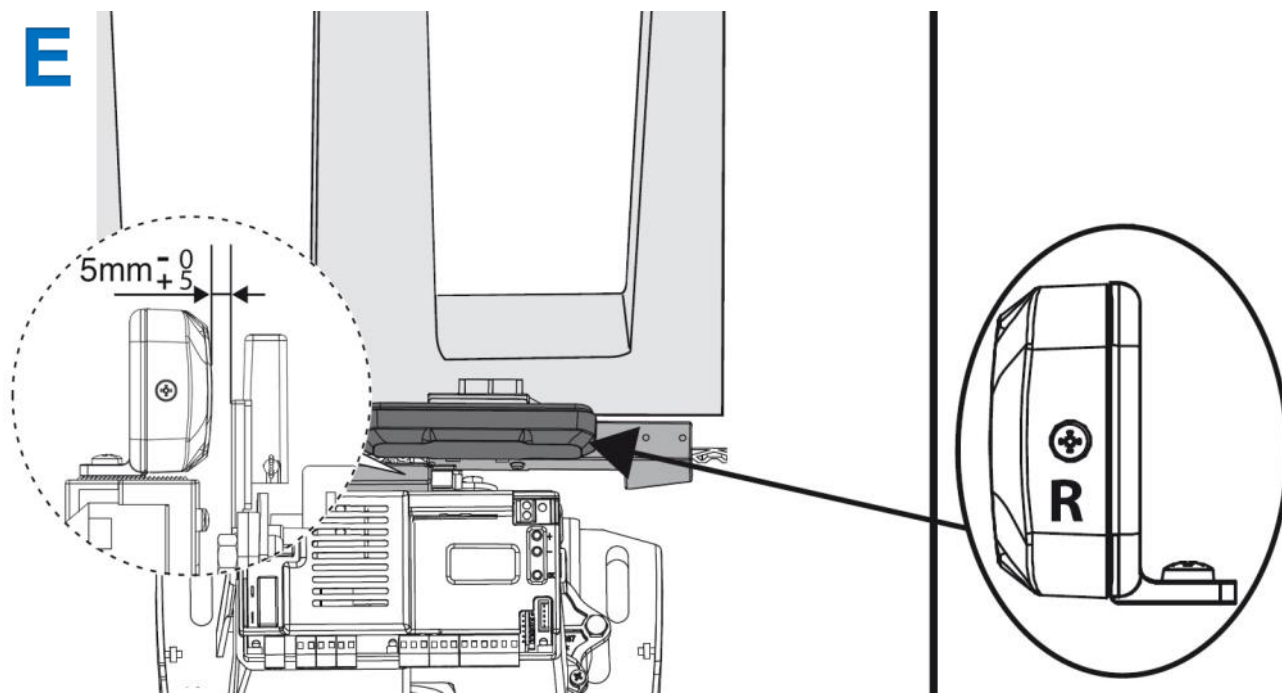

4- Operator wiring

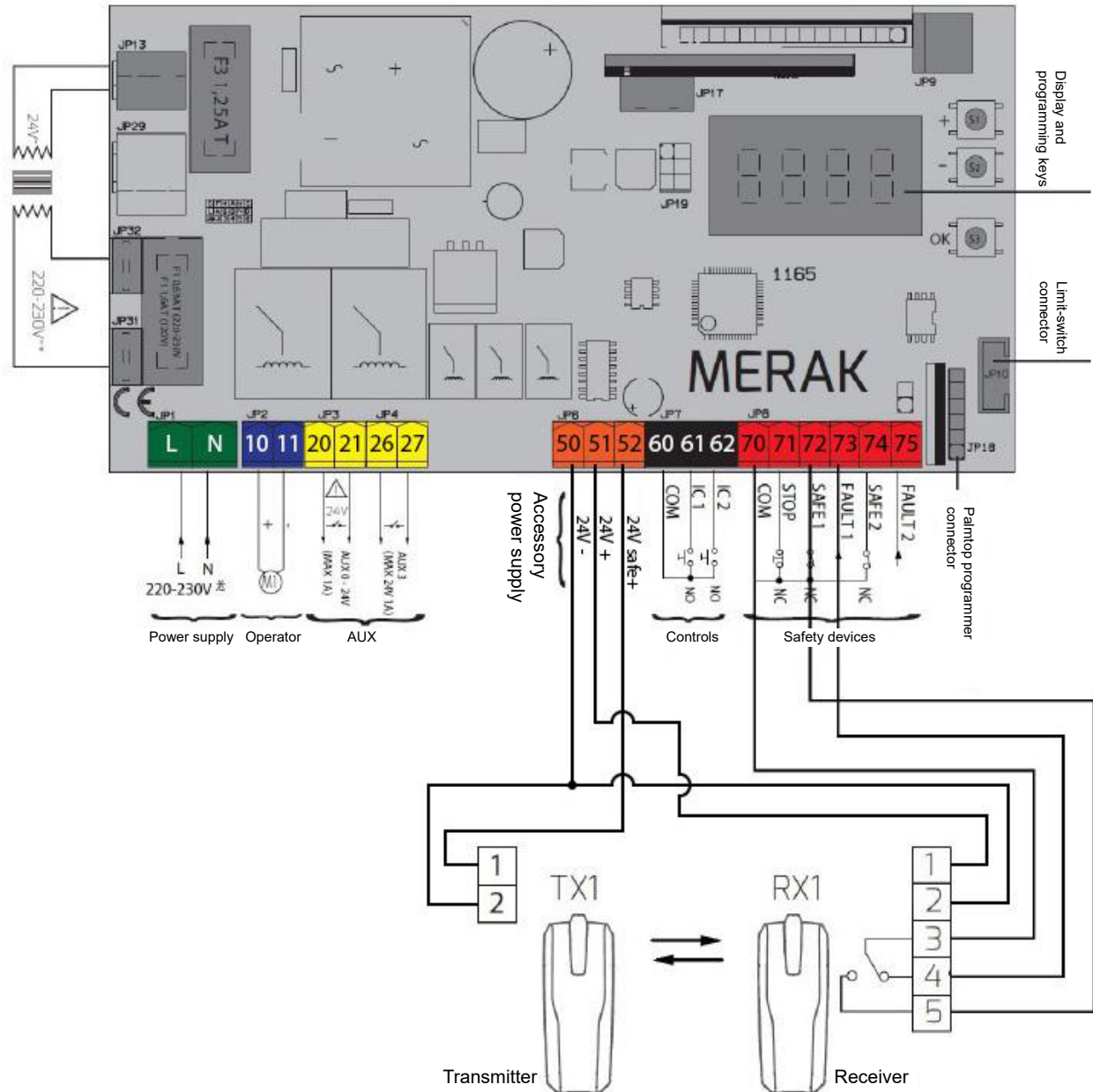

! Remove the used output bridges, the others are original outputs

5- Programming the operator

A- Simple menu: Basic settings

Operator at halfway point and engaged:



- Press 1 x OK (`LRnGARGE` appears), press 1 x `-` (`ENG` English) + `OK` `x1` OK.
- Select the direction `d ir` (opening direction) choice of (`RGT` or `LFT`) internal view + `OK` `x1` OK.
- Choice of `Pr-ESEL` (`Rr` :auto closing) or (`Sr` : semi-auto closing), select + `OK` `x1` OK.
- Start the autotest with the gate at the halfway point, it will close.

If it is not a closing operation, press `+` and `-` at the same time.

Reconnect the operator in the correct direction (refer to menu: Direction `d ir`).

When the autotest is complete, OK will appear on the display.

- Start programming the remote controls: `REC REMOTE` will appear on the display, wait a moment. The screen will then display `HIDDEN KEY` : You can now program your remote controls.

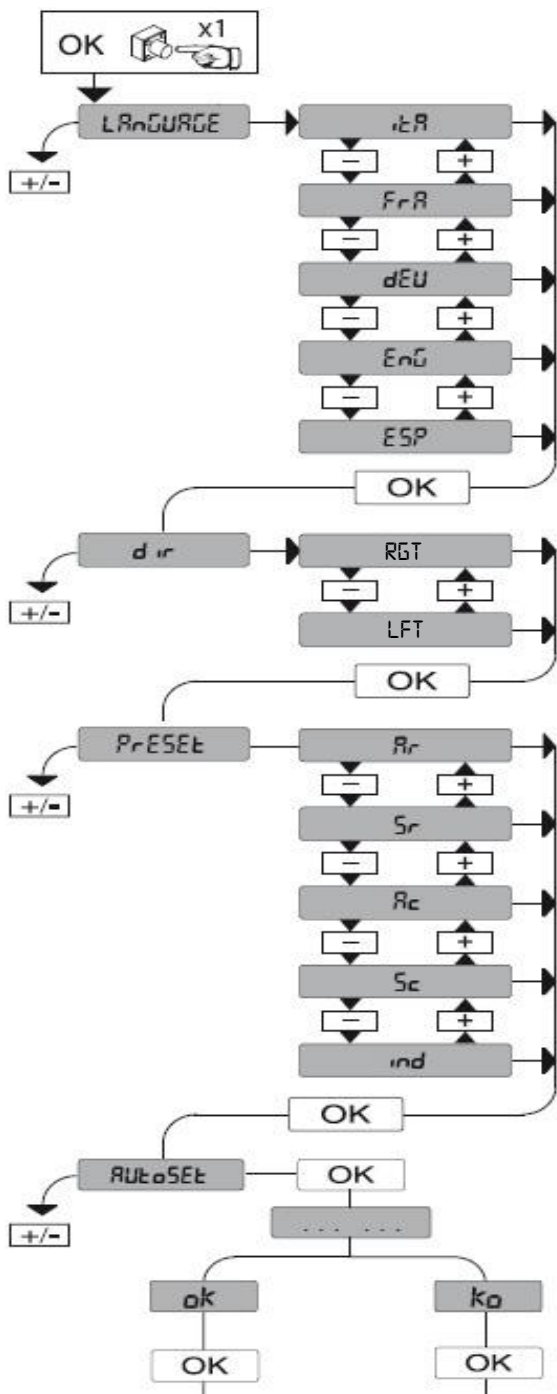

SUO: Gate open
SUC: Gate closed

PRESET	DEFAULT	Rr	Sr	Rc	Sc	ind
PARAMETER						
Automatic closing time	40	40	40	40	40	40
LOGICS						
Stepwise movement	0	1	0	1	0	0
Pre-alarm	0	0	0	1	1	0
Individual present	0	0	0	0	0	1
Pulse locking during opening	0	0	0	1	1	0

RGT: operator installed on the right

LFT: operator installed on the left

Rr: automatic operation, residential

Sr: semi-automatic operation, residential

Rc: automatic operation, collective

Sc: semi-automatic operation, collective

ind: operation with individual present

B- Programming a remote control:

- Access the radio menu **rAd lo**.
- Select the required channel (**RdJ StArE** total opening) or (**RdJ Zch** for the 2nd channel), then press OK.

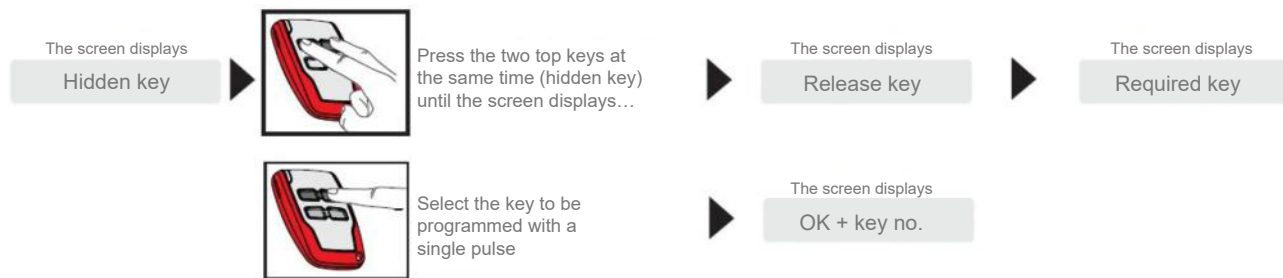

6- Advanced programming of the operator

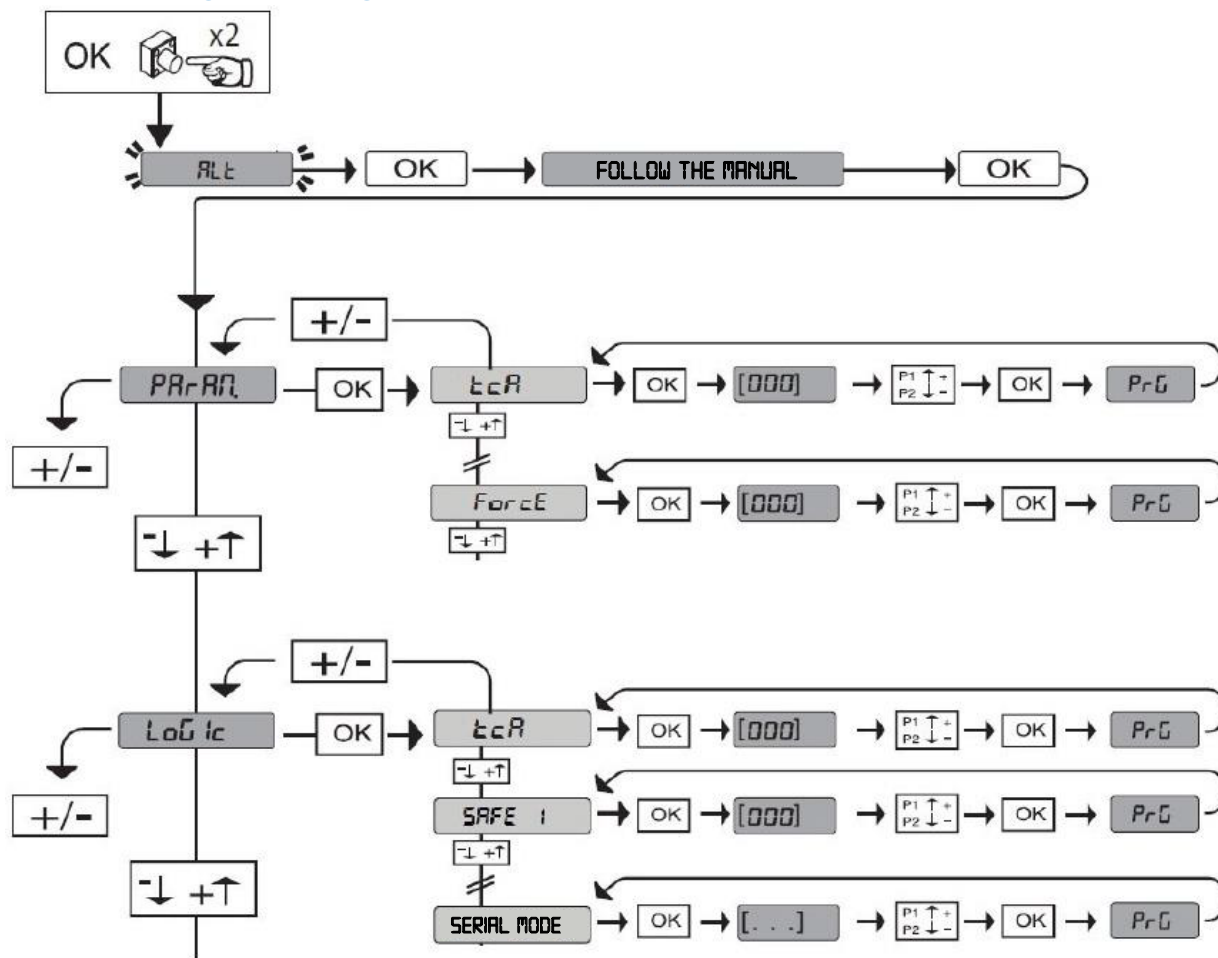

Setting the automatic closing time:

Parameter	Min.	Max.	Default	Personal	Definition	Description
ACT	0	120	10		Automatic closing time(s)	Waiting time before automatic closing

Setting the forces:

⚠ It is recommended to add an additional 10%, once the autotest has been completed.

OPEN FORCE	1	99	50		Force of leaf/leaves during opening [%]	Force exerted by the leaf (leaves) during opening. Represents the percentage of force exerted, other than that saved during autoconfiguration (and subsequent updates) before the obstacle alarm is activated. This parameter is automatically configured during autoconfiguration. ⚠ CAUTION: This has a direct effect on the force of impact: check that the configured value complies with current safety regulations (*). Install anti-crush safety devices if necessary (**).
CLOSE FORCE	1	99	50		Force of leaf/leaves during closing [%]	Force exerted by the leaf/leaves during closing. Represents the percentage of force exerted, other than that recorded during autoconfiguration (and subsequent updates) before the obstacle alarm is activated. This parameter is automatically configured by the autoconfiguration function. ⚠ CAUTION: This has a direct effect on the force of impact: check that the configured value complies with current safety regulations (*). Install anti-crush safety devices if necessary (**).
SLOW OPEN FORCE	1	99	50		Force of leaf/leaves during slow opening [%]	Force exerted by the leaf/leaves during opening at slow speed*. Represents the percentage of force exerted, other than that recorded during autoconfiguration (and subsequent updates) before the obstacle alarm is activated. This parameter is automatically configured by the autoconfiguration function. ⚠ CAUTION: This has a direct effect on the force of impact: check that the configured value complies with current safety regulations (*). Install anti-crush safety devices if necessary (**).
SLOW CLOSE FORCE	1	99	50		Force of leaf/leaves during slow closing [%]	Force of leaf/leaves during slow closing [%]. Represents the percentage of force exerted, other than that saved during autoconfiguration (and subsequent updates) before the obstacle alarm is activated. This parameter is automatically configured by the autoconfiguration function. ⚠ CAUTION: This has a direct effect on the force of impact: check that the configured value complies with current safety regulations (*). Install anti-crush safety devices if necessary (**).

Activation/Deactivation of automatic closing:

Logic	Definition	Default	Indicate the configured setting	Options
RCT	Automatic closing time	0	0	Logic not activated
			1	Activates automatic closing

Activates the cell, during closing only:

SAFE 1	Configuration of the safety input SAFE 1.72	5		
			0	Input configured as Phot, photocell.
			1	Input configured as Phot test, photocell.
			2	Input configured as Phot op., photocell active during opening only.
			3	Input configured as Phot op. test, tested photocell active during opening only.
			4	Input configured as Phot cl, photocell active during closing only.
			5	Input configured as Phot cl test, tested photocell active during closing only.

Configure the uplink boards in opposite mode:

SERIAL MODE	Serial mode (indicates how to configure the board in a BFT network connection)	0		
			0	SLAVE standard: the board receives and gives commands/diagnostics/etc.
			1	MASTER standard: the board sends activation commands (START, OPEN, CLOSE, PED, STOP) to other boards.
			2	SLAVE opposing sliding leaves in a local network: the board is the slave in a network with opposing leaves without intelligent module (FIG.R).
			3	MASTER opposing sliding leaves in a local network: the board is the master in a network with opposing leaves without intelligent module (FIG.R).

7- Install the Battery Kit

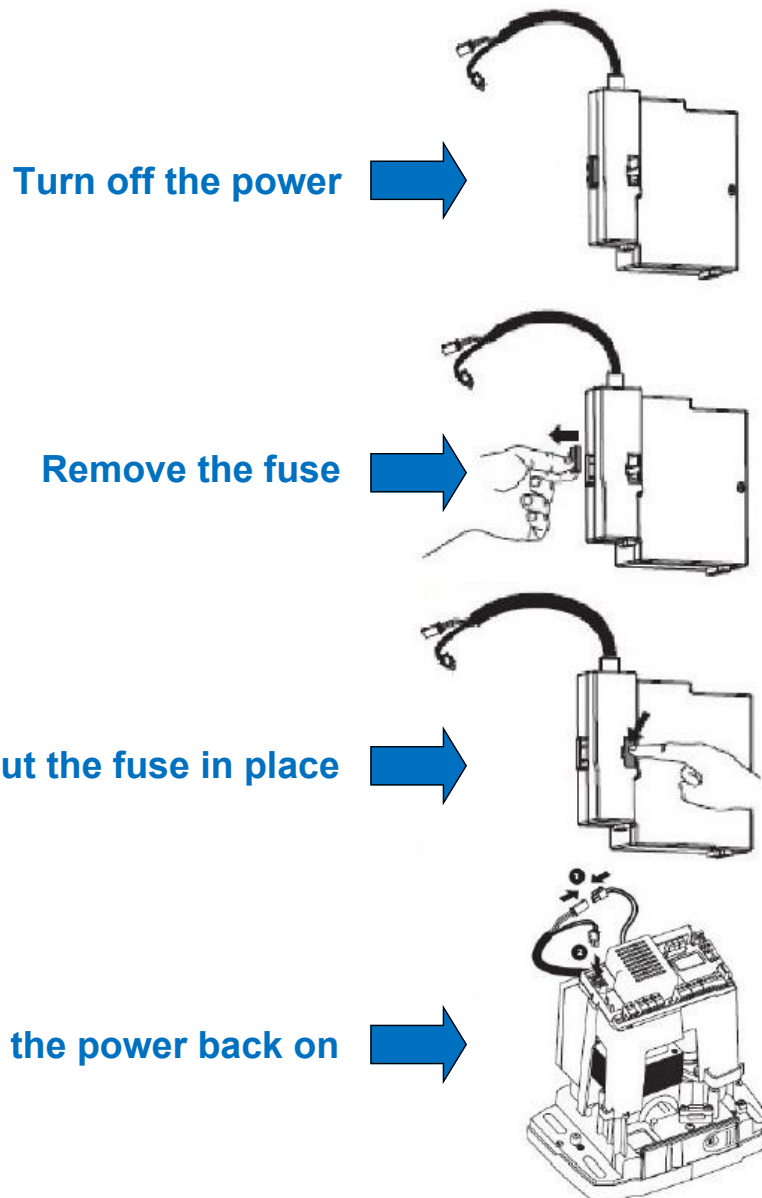

8- Error table

Diagnostic code	Description	Comments
StRE	START E External start input activation	
StRI	START I Internal start input activation	
oPEn	OPEN input activation	
cLS	CLOSE input activation	
PEd	PED Pedestrian input activation	
tME	TIMER input activation	
StoP	STOP input activation	
PhoE	PHOT Photocell input activation	
PhoP	PHOT OP Photocell during opening input activation	
PhoCL	PHOT CL Photocell during closing input activation	
bARr	BAR Header input activation	
bARr 2	BAR header on slave operator input activation (opposing leaves connection)	
SWC	SWC operator close limit-switch input activation	
SWO	SWO operator open limit-switch input activation	
SEt	The board waits to perform a full opening-closing maneuver without being interrupted by the intermediate stops, in order to obtain the torque required for movement.(opposing leaves connection) CAUTION! The obstacle detection function is not activated.	
Er01	Photocell test error	Check the photocell connection and/or the logic configurations
Er02	Header test error	Check the header connection and/or the logic configurations
Er03	Open photocell test error	Check the photocell connection and/or the logic parameter configurations
Er04	Close photocell test error	Check the photocell connection and/or the logic parameter configurations
Er05	Header test on slave operator error (opposing leaves connection)	Check the photocell connection and/or the logic configurations
Er06	8k2 Header test error	Check the photocell connection and/or the logic configurations
Er1H*	Board hardware test error	- Check the operator connections - Hardware problem with the board (contact Customer Services)
Er3H*	Reverse due to obstacle - Amperostop	Check for any potential obstacles in the gate's path
Er5H*	Communication error with remote devices	Check the connections with the accessory devices and/or the expansion boards with serial connection
Er7H*	Internal checking error of supervision system	Try turning the board on and off. If the problem persists, contact Customer Services.
ErFH*	Limit-switch error	Check the limit-switch connection

Please note: If you require more information on the operators;
Refer to the supplier's manual found in the operator pack.

