

Installation & Programming manual N°7132

06/19

Sectional doors Industry & Large Villa

Intellidrive 400

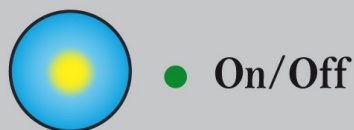

CE

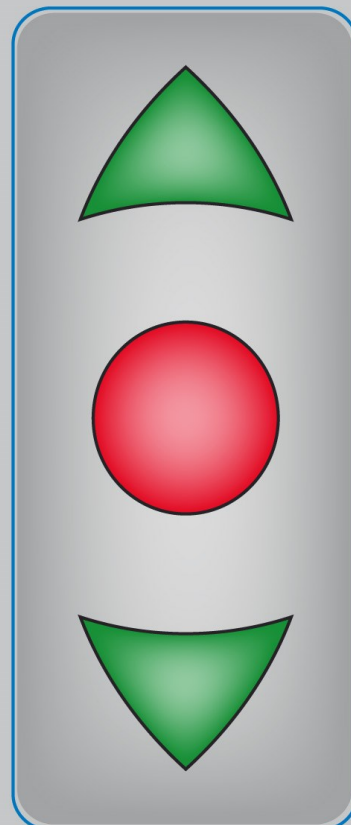

Modification :
Emergency maneuver mounting

(Document reserved for installers)

Summary

Material needed	p.2
Installation instructions.....	p.3
Motor mounting and the emergency maneuver.....	p.4
Basic connection of the cabinet	p.7
Visualization of the cabinet	p.8
List of programs	p.9
Putting the cabinet into operation.....	p.10
Determining the direction of rotation	p.10
"Maintained pressure" mode (default).....	p.10
Adjustment of closing speed	p.11
<u>Learning of the run + 1 validation cycle</u>	p.11
Other modes of operation :	
Mixed mode, impulse mode.....	p.12, p.13
Modification of the closing timeout for automatic modes	p.14
"Sequential", "Auto", "Blocking" automatic mode.....	p.15 to p.17
Partial opening programming on the cabinet	p.18
Memorization of the remote control	p.20
Reading the last 10 errors.....	p.23
Reading and erasing cycle counter.....	p.23
Connecting accessories.....	p.24
LED indication.....	p.28
Come back "maintained pressure" mode.....	p.28
Summary of screen messages	p.29
Operation errors.....	p.30
Emergency maneuver	Last page

Material needed

- | | |
|--|--|
| <ul style="list-style-type: none"> - Ladders - Tape measure (5M) - Hammer drill - Screwdriver with tips - Pegs with screws (Ø6 max) and drills concrete | <ul style="list-style-type: none"> - Hammer - Flat key of 6 mm - Hex key of 4 mm & 6 mm - Screwdriver - Grease with brush - Cutter |
|--|--|

Installation instructions

WARNING !



To ensure that this product is assembled, used and maintained in complete safety, it is important to follow the instructions provided in this document. For everyone's safety, please observe the precautionary measures below.



- * Before beginning the assembly, read this manual carefully.
- * This closure must be installed by a professional technician.
- * All the parts delivered are specifically sized for this product. Adding and/or using other parts may be detrimental to safety and may affect the product's warranty.
- * Any modification or improvement of this closure must be compliant with the standard EN 13241 + A2. In this case, a "modification/transformation" file must be created by the installer as per the standard EN 12635 annex C.
- * The torsion springs exert considerable force. This work must therefore be carried out in accordance with the safety instructions. Use the appropriate tools to install these products. Ensure that the work is carried out on a stable floor.
- * Ensure that the assembly area is adequately lit, clear, clean and clearly marked out.
- * Ensure that no other people are present at the assembly site apart from the installers. Non-authorized persons (children for example !) who are present at the site risk injury during assembly.
- * All the components of this closure must be installed in compliance with the installation instructions provided in this manual.
- * All the requirements of the standards EN 13241 + A2 must be met and verified if necessary.



- Before starting the mounting of the motorization, it is essential to ensure that the door operates manually with no problem.
- It must not be under-compensated or over-compensated and must not present any hard points during maneuvers.
- European standard 13241 + A2 requires from "safeties" that do not permit the motorization of an improperly installed door.

Motor mounting

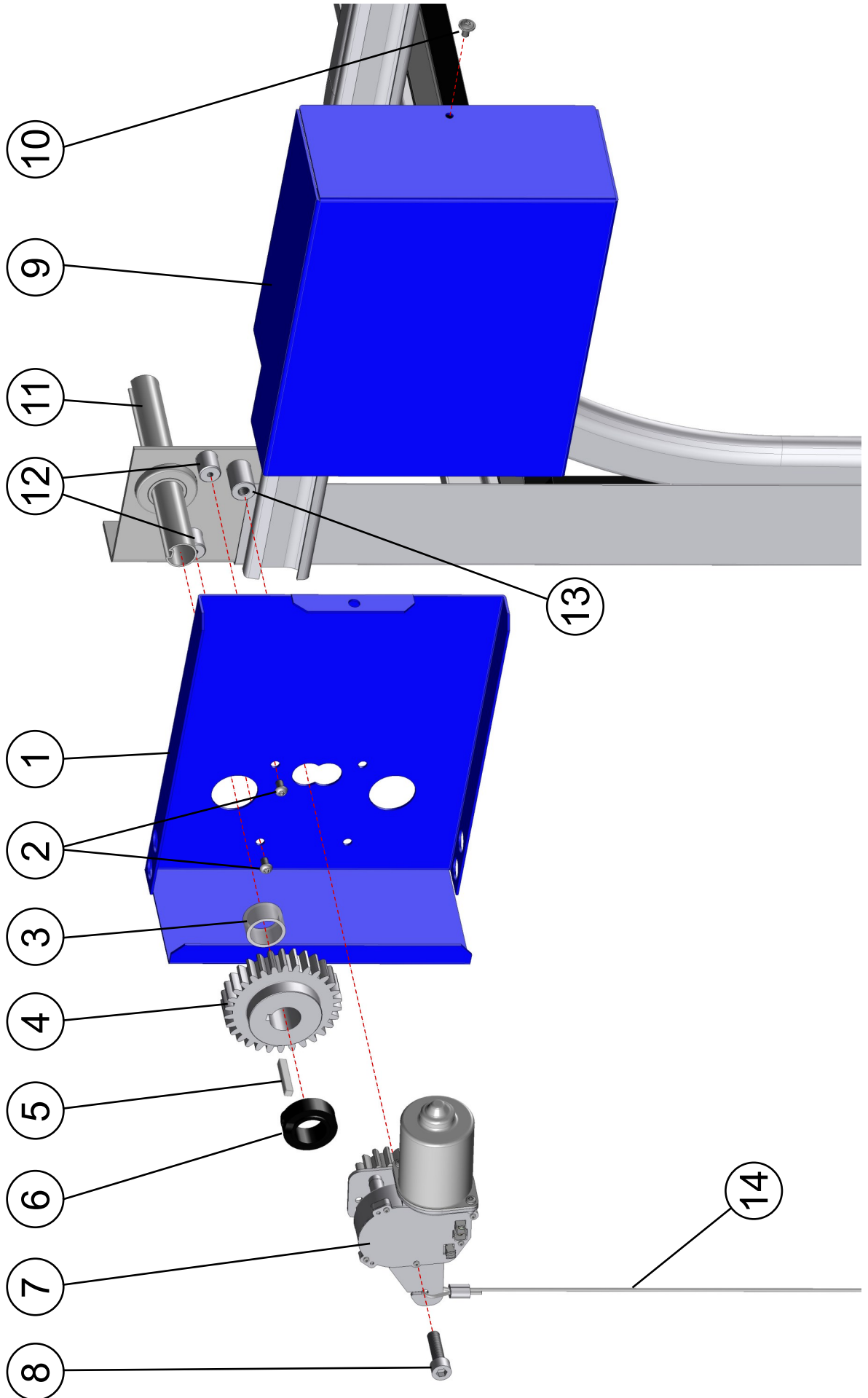

Motor mounting

Important :

The side of the motor has been defined at the command, it cannot be modified at the installation.

- A) - Mount the 2 cable glands at the bottom of the housing ①.
(Attention the bottom of the housing is reversible, check if the motor is on the right or on the left before mounting the cable glands).
- B) - Mount the spacer ③ on overflowing axis Ø25,4 mm ⑪.
- C) - Insert the housing base ① on overflowing axis Ø25,4 mm ⑪ and the tackle on the 2 fixing shoulders ⑫ located on the bearing.
- D) - Fix the housing base ① on the fixing shoulders ⑫ with the 2 screws M6x10 ②.
- E) - **Mounting of the sprocket ④ :**
 - 2 possible cases :
 - On the Ø25,4 mm grooved hollow axis :
 Use only the short key 6,3x9,5x32 mm ⑤.
 - On the Ø25,4 mm grooved full axis :
 Use only the short key square shaped 6,35x6,35x32 mm ⑤.
Procedure :
 Gently tap on the sprocket (shoulder turned towards the end of the axis Ø25,4 mm) to push it until the spacer ③.
- F) - Lock the sprocket laterally ④ with the stop ring ⑥ and its clamping screw.
- G) - Fix the motor assembly ⑦ on the motor support ⑬ with the shoulder screw ⑧.
 - **Important :** Before mounting, do not forget to remove "the transport nut" from the shoulder screw ⑧.

- H) - Connection of the motor ⑦ :
 - Plug in the electrical connector with the aid of the encoding lug.

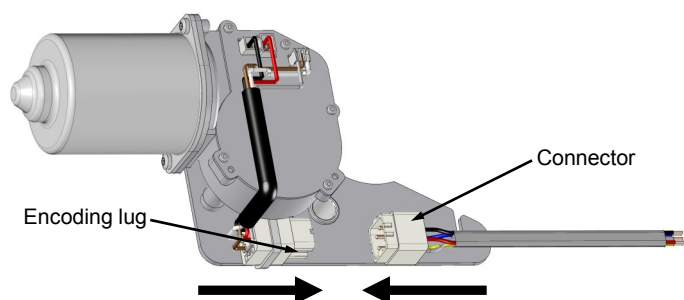

- I) - Pass the end of the cable attached to the motor in the cable gland.
 Before tightening the cable gland, check that the motor ⑦ can switch freely on its support, without stress for the electric cable.
- J) - Hook the clutch cable loop onto the swivel bracket of the motor assembly.
 Pass the loop of the cable ⑭ in the light provided for this purpose.
- K) - **Imperatively lubricate the drive sprockets with the supplied grease tube.**
 (These sprockets, not greased, become noisy after a few cycles).
- L) - Mount the cover ⑨ on the bottom of the housing ① and lock with the screw 6x10 ⑩.

Emergency maneuver mounting

1

Lift the handle

2

Screw the hook

3

Insert the spring

Important : Close loop

4

Important : Tensed cable

Squeeze the loop!

The sprockets must not engage.

Install the cable

5

Warning: Nuts should be on the active strand.

Mount the cable clamp

6

Important : The sprockets must be engaged.

90^{±2} mm

Check the rating of the spring

7

If poor rating obtained

A

B (remove the loop)

C (screw or unscrew to get the rating) 90^{±2} mm (see picture 6)

D (hang the loop again)

E (lock)

After adjusting the spring rating, the emergency maneuver is now locked. You can install the pin with its label.

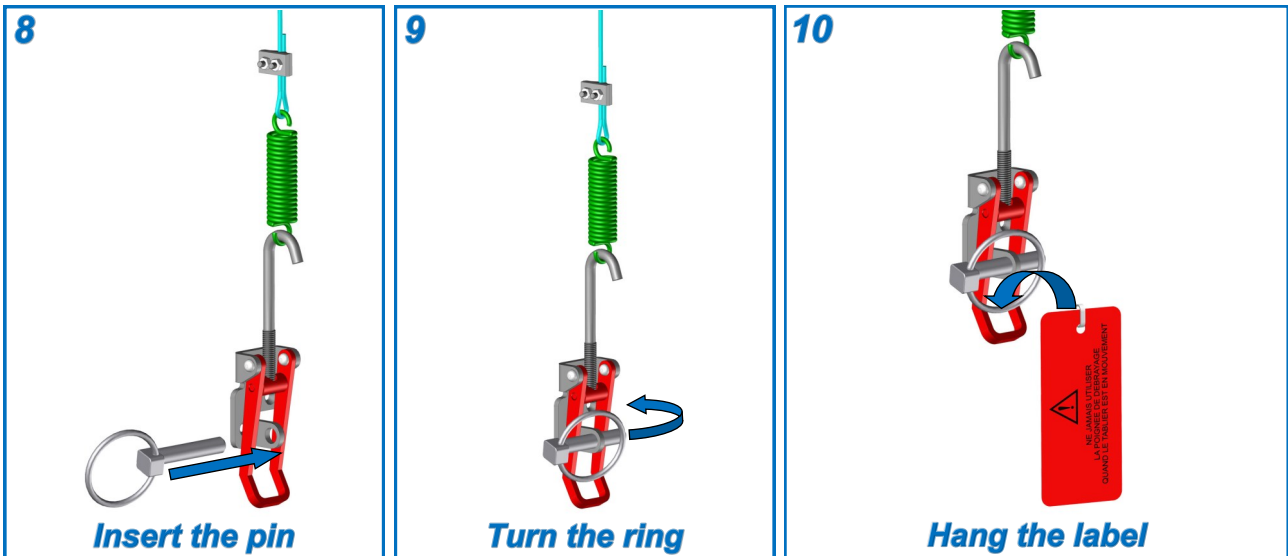

Basic connection of the cabinet

For modes of operation :

- Maintained pressure, mixed, user trained :
 - Outside of a public area.
- Impulse, user trained :
 - In view or out of sight of the door, Outside of a public area.
 - In view of the door, in a public area.

Note : Supply mandatory in 230V monophased.

For local with 400V three-phase only, the connection to the cabinet of one phase and neutral gives 230V monophased.

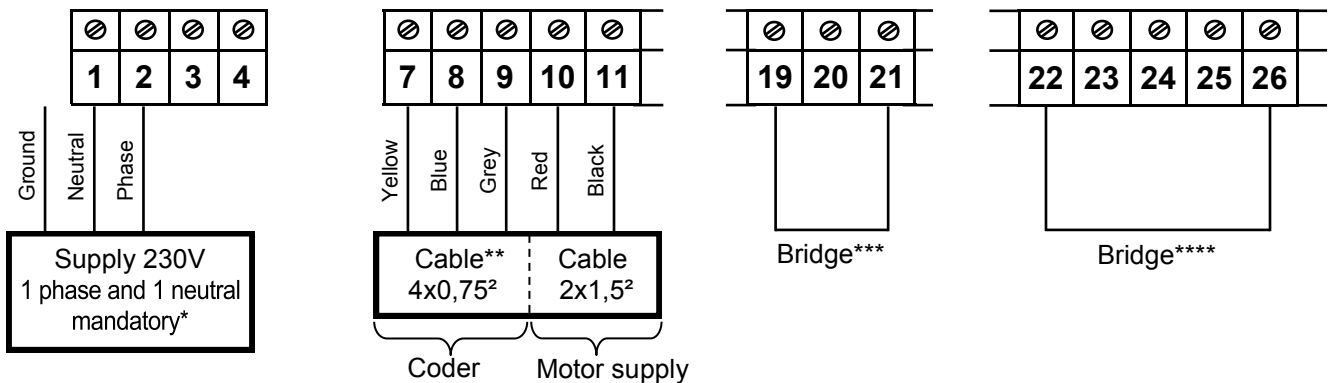

Note : * Use of 2 phases on terminal blocks 1 and 2 would deteriorate the platen.

** Green wire is not used.

*** Check the presence of bridging between the terminals (19) and (21).

**** Check the presence of bridging between the terminals (22) and (26).



Provide protection of the supply line of the cabinet by an upstream differential circuit breaker and a adapted thermal protection.

Visualization of the cabinet

Facade

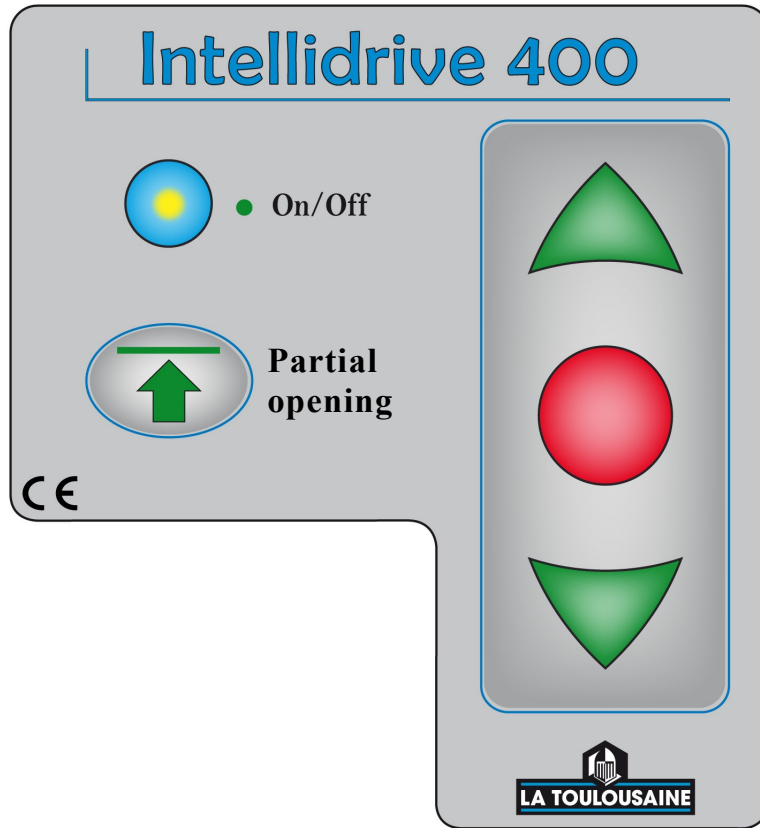

Programming interface

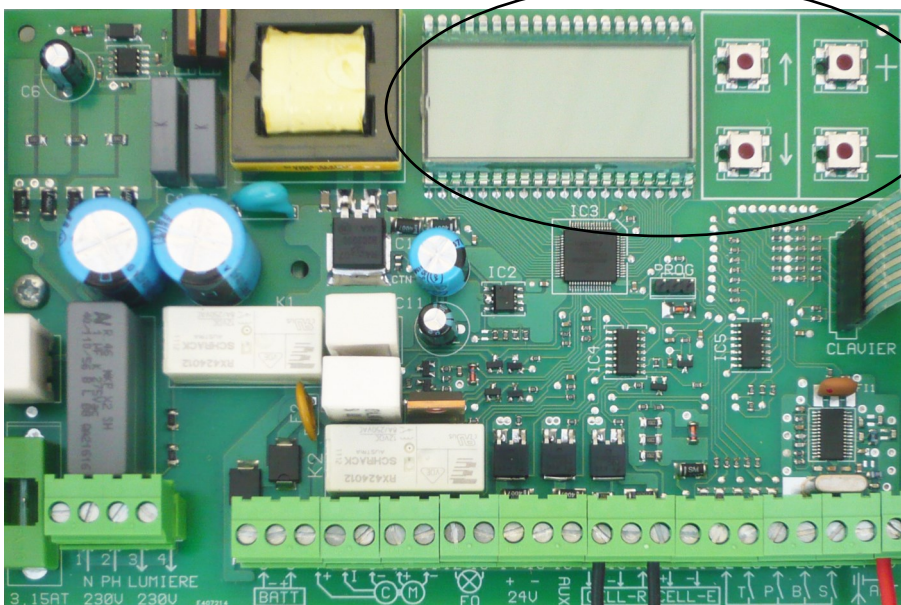
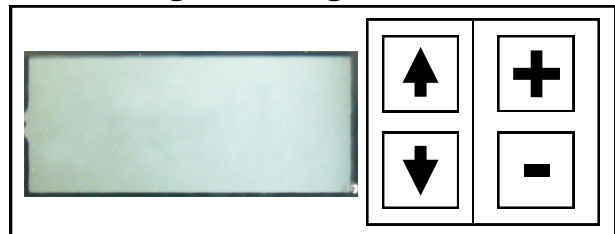

Programs list

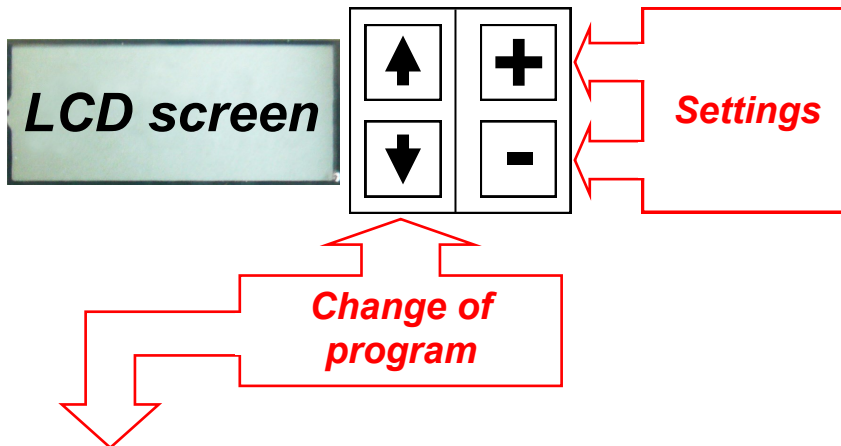

PROGRAMS	DESIGNATIONS	OBSERVATIONS
P1	Speed adjustment	70, 75 or 80
P2	Learning of the run	
P3	The operating mode	CO : Maintained pressure CI : Mixed IP : Impulse AS : Automatic Sequential AA : Automatic Auto AB : Automatic Blocking
P4	Modification timeout	
P5	Memorization remote control	
P6	Memorization remote control (partial opening)	
P7	Erasing a button from the remote control	
P8	Erasing all remote controls	
P9	Reading the last 10 errors	
Pa	Number of remote controls (in memory)	
Pb	Reading (general cycle counter)	
Pc	Reading or erasing (temporary cycle counter)	
Pd	Inactive	
Pe	Inactive	

Important : After settings, always return to **Att** position (standby)

Putting the cabinet into operation

 **Control before any programming :**
 Door should be perfectly compensated and balanced.

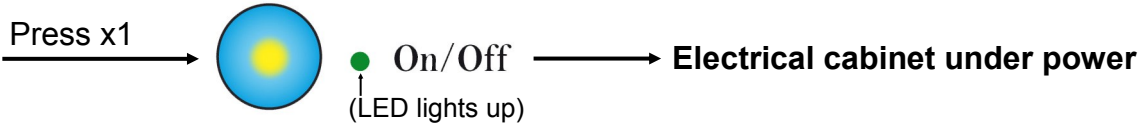

Determining the direction of rotation

- Position the door at mid-height, using the emergency maneuver.
- Press  continuously, if the door closes, invert the feeder wires of motor at terminals ⑩ and ⑪.

"Maintained pressure" mode (default) (maintained mounted/descent)

IMPORTANT :
 In the case of connection of a control member or safety device, it is imperative to perform an apprenticeship to make the entries 22/23/24/25/26 functional.
 See chapter : *Learning of the run.*

Display on the LCD screen :

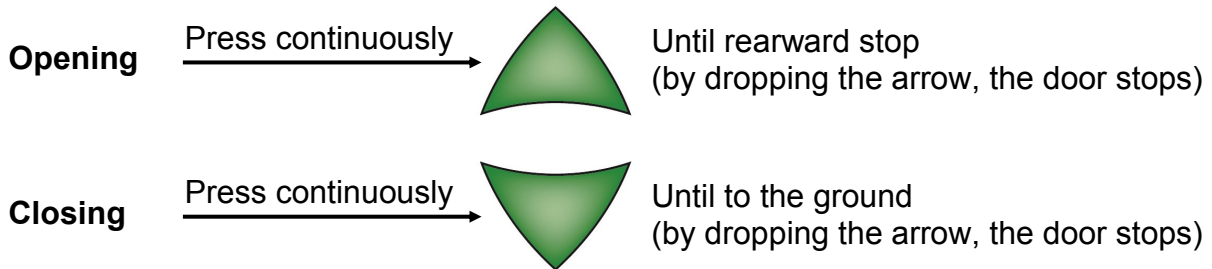

Adjustment of closing speed

The descent speed of the door is already pre-set in factory.
For some dimensions, it can be adjusted.

! In case of adjustment, compliance with the charter below is imperative.

- **Charter to be respected** : Surface of the apron > to 15m² → 70 (Initial configuration)
- 15 m² ≥ Surface of the apron > to 10 m² → 75
- Surface of the apron ≤ to 10 m² → 80

➤ **Procedure :**

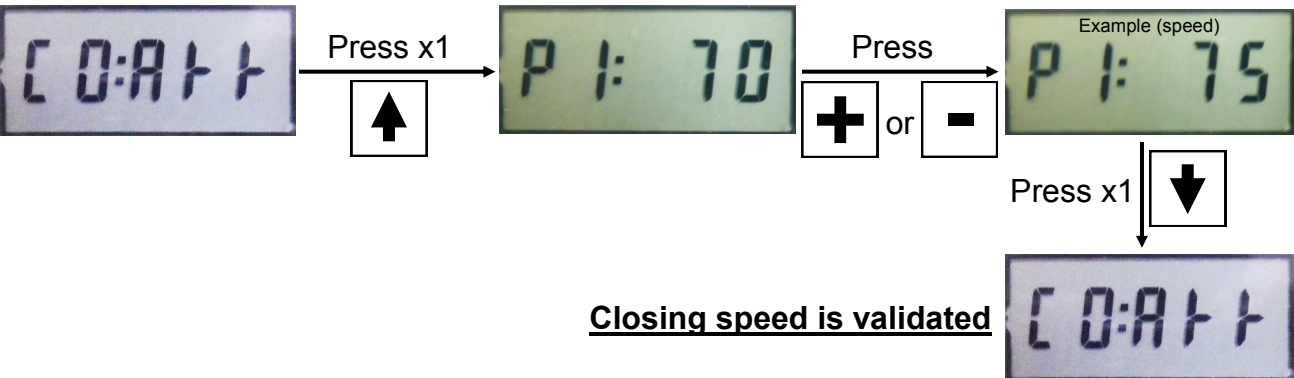

Learning of the run + 1 validation cycle

! Never perform lifting or squeezing tests during the learning phases.
LEARNING must be performed before programming the following operating modes : Mixed, Impulse, Automatic.

➤ **Procedure :** Door closed

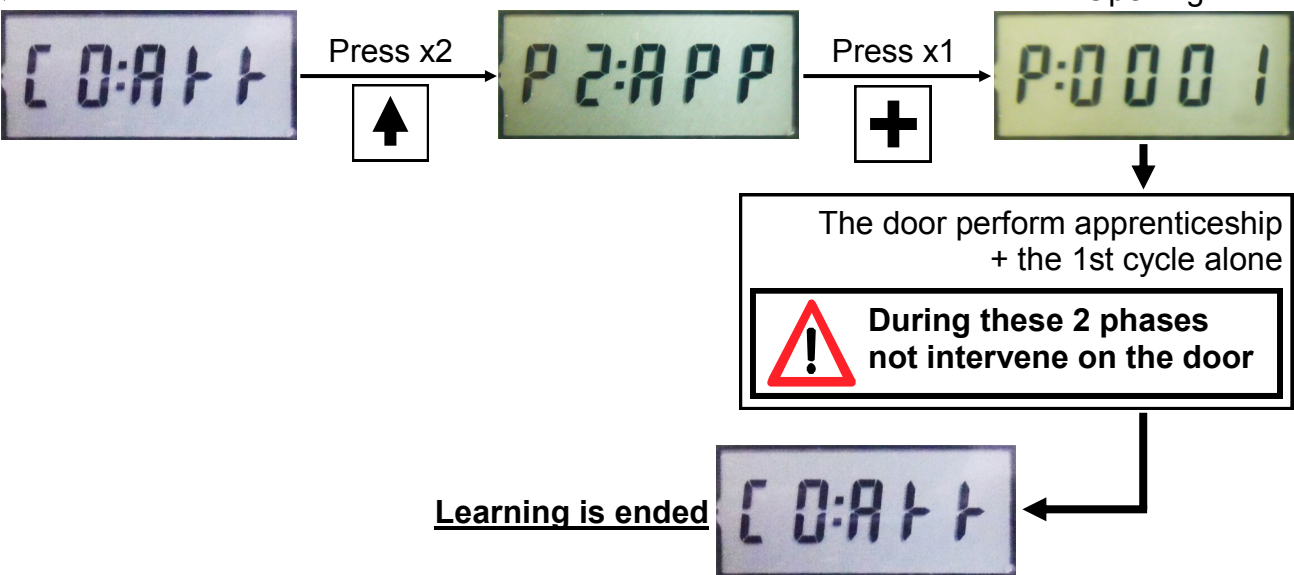

Important : If screen display an error, see chapter : Operation errors.

Other modes of operation

Mixed mode *(mounted impulse/maintained descent)*

➤ **Programming** : Door closed

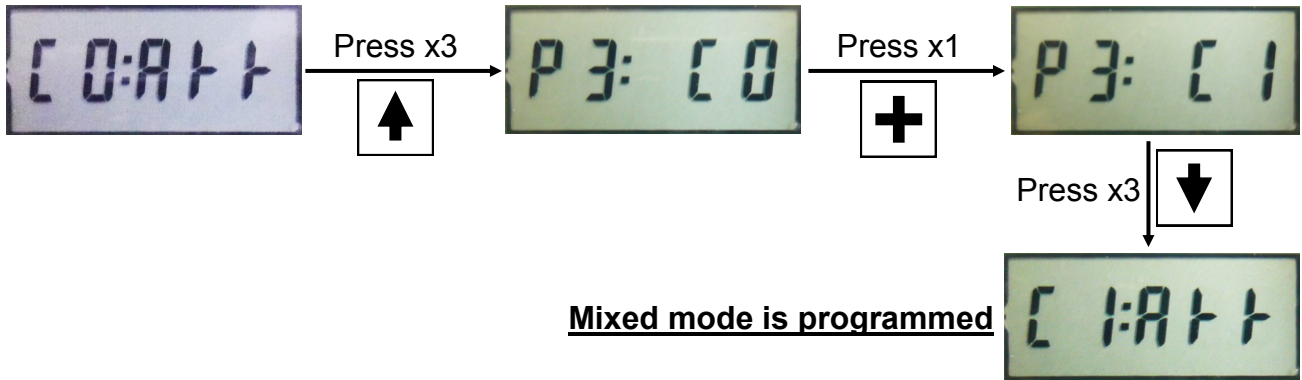

➤ **Operation** :



Note :

***During opening** → Press x1  → Stop of the door

***During closing** → Let go  → Stop of the door

Important : If screen display an error, see chapter : Operation errors.

Impulse mode *(mounted/descent impulse)*

➤ **Programming** : Door closed

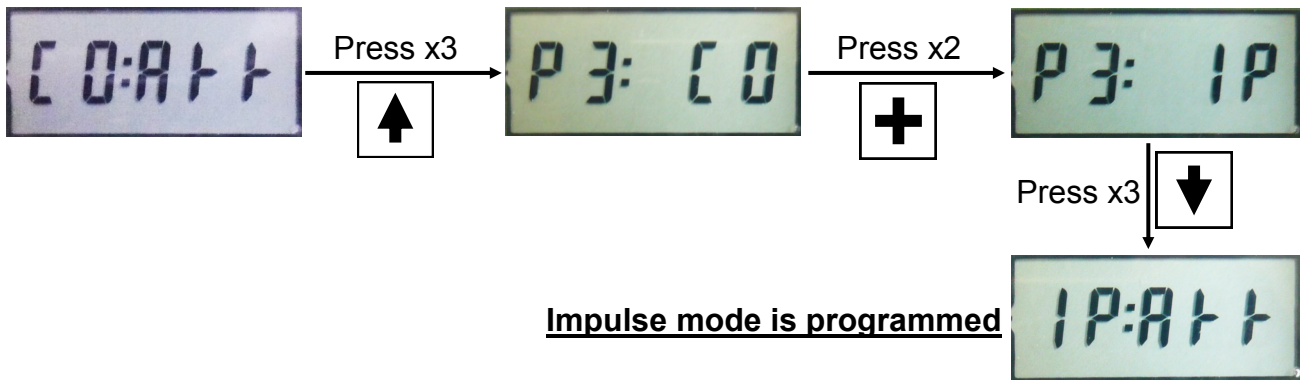

➤ **Operation** :



Note :

***During opening or closing** → Press x1 → Stop of the door

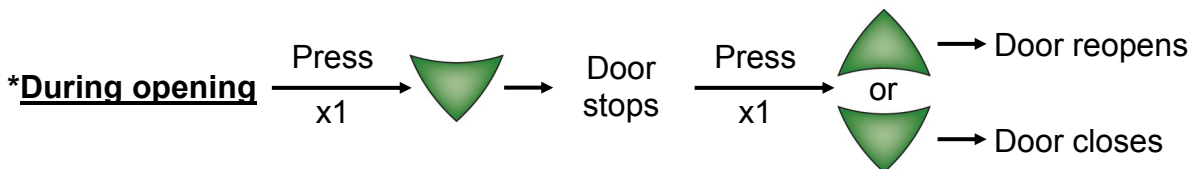

***During closing** → Press x1 → Door reopens

Important : If screen display an error, see chapter : Operation errors.

Modification of the closing timeout for automatic modes

➤ **Programming :**

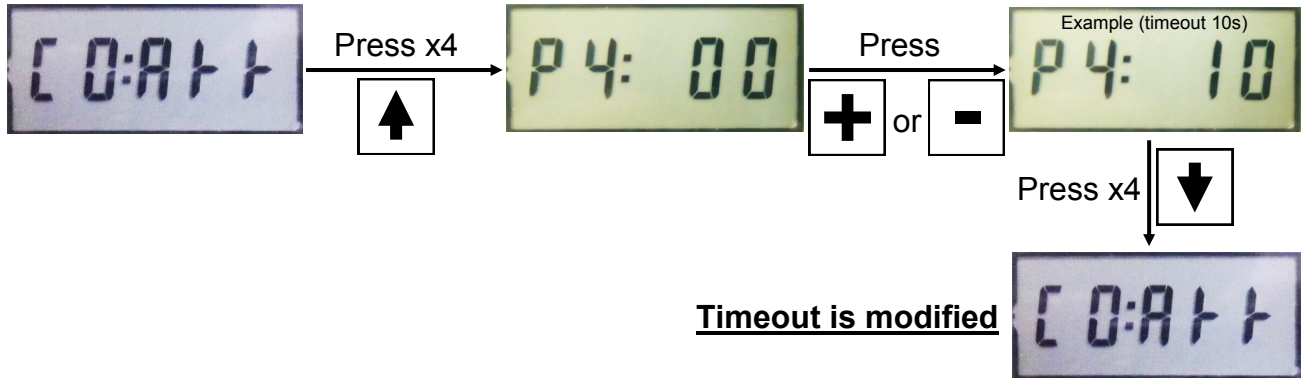

➤ **Cancellation of the timeout :**

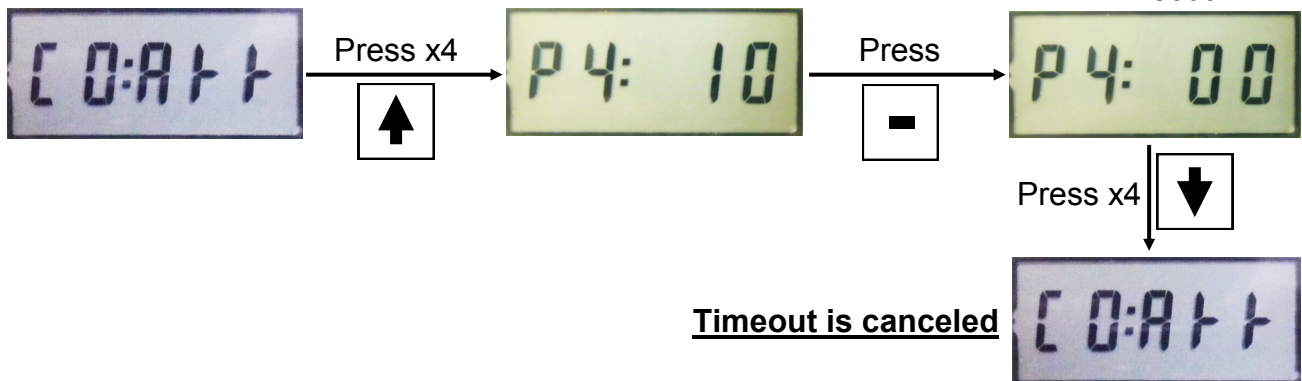

Note :

- *Timeout is used in** → The "sequential" automatic mode
 → The "auto" automatic mode
 → The "blocking" automatic mode

"Sequential" automatic mode

(mounted impulse + timeout and automatic closing)

This programming can only be achieved after mandatory connection of 2 sets of cells (Standard EN 13241-1).

➤ **Programming** : Door closed

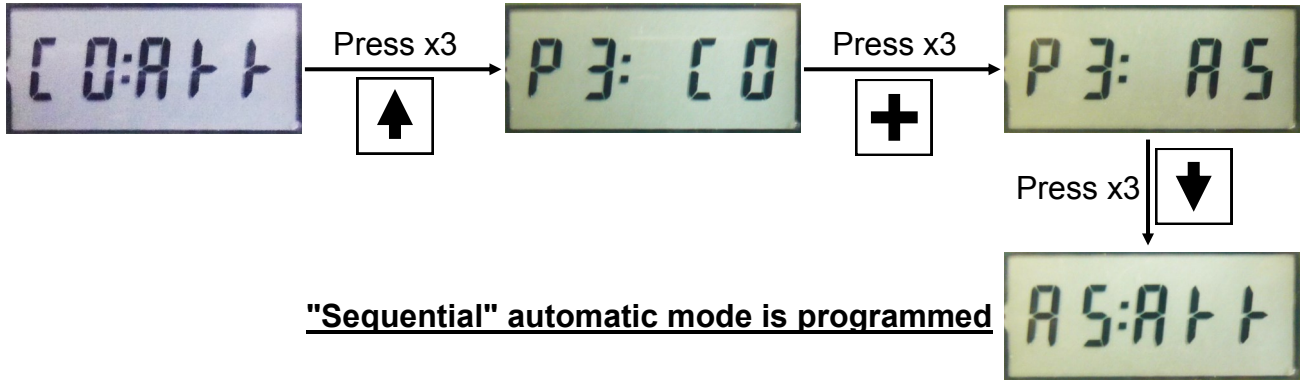

➤ **Operation** :

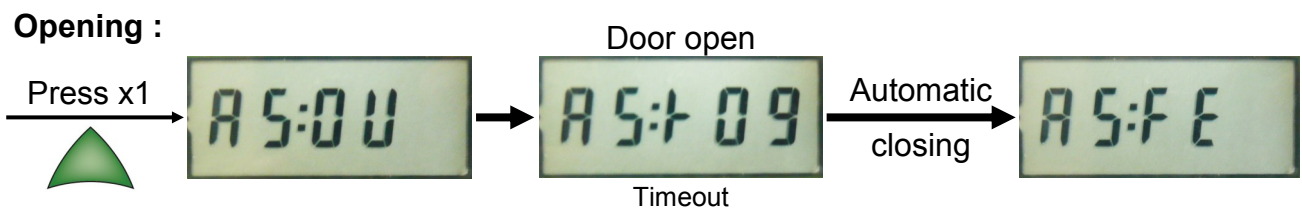

Note :

***During opening or closing** → Press x1 → Stop of the door

***During opening** → Press x1 → Door stops → Press x1 or → Door reopens or Door closes

***During closing** → Press x1 or cells interruption → Door reopens

***During timeout** → Press x1 → Timeout re-launches

→ Press x1 → Timeout stops

→ Press x1 → Door closes without waiting for the end of the timeout

Important : If screen display an error, see chapter : Operation errors.

"Auto" automatic mode

(mounted automatic + timeout and automatic closing)
Recommended for opening by road tube, magnetic loop or cells

This programming can only be achieved after mandatory connection of 2 sets of cells (Standard EN 13241-1).

➤ **Programming** : Door closed

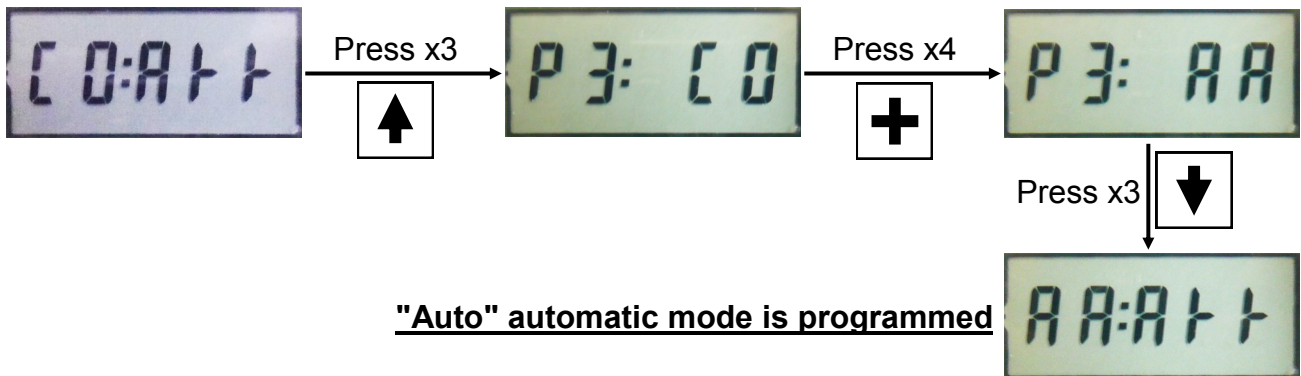

➤ **Operation** :



Note :

***During opening or closing** → Press x1 → Stop of the door

***During opening** → Press or cells interruption → Door continues to open

***During closing** → Press x1 or cells interruption → Door reopens

***During timeout** → Press x1 → Timeout re-launches

→ Press x1 → Timeout stops

→ Press x1 → Door closes without waiting for the end of the timeout

Important : If screen display an error, see chapter : Operation errors.

"Blocking" automatic mode

(mounted automatic then during a passage the timeout is reduced)
Recommended for opening by road tube, magnetic loop or cells

 This programming can only be achieved after mandatory connection of 2 sets of cells (Standard EN 13241-1).

➤ **Programming** : Door closed

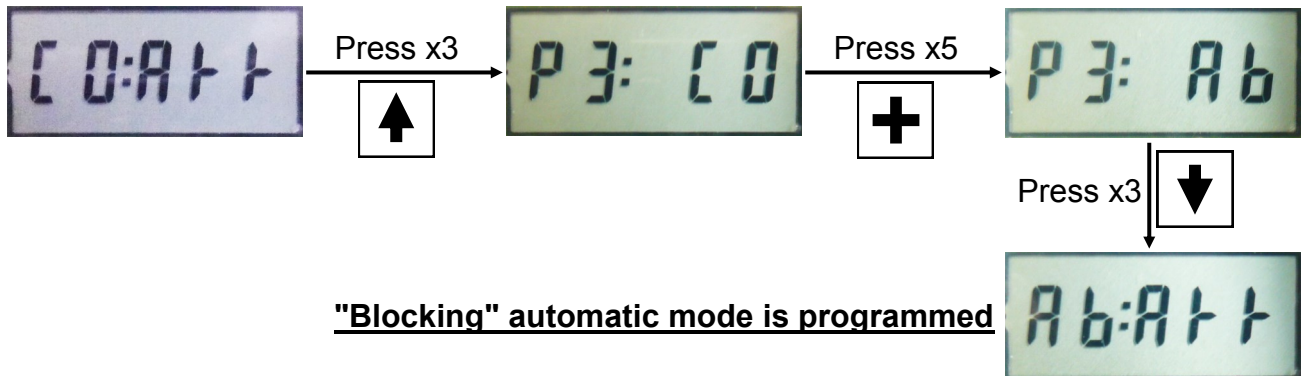

➤ **Operation** :

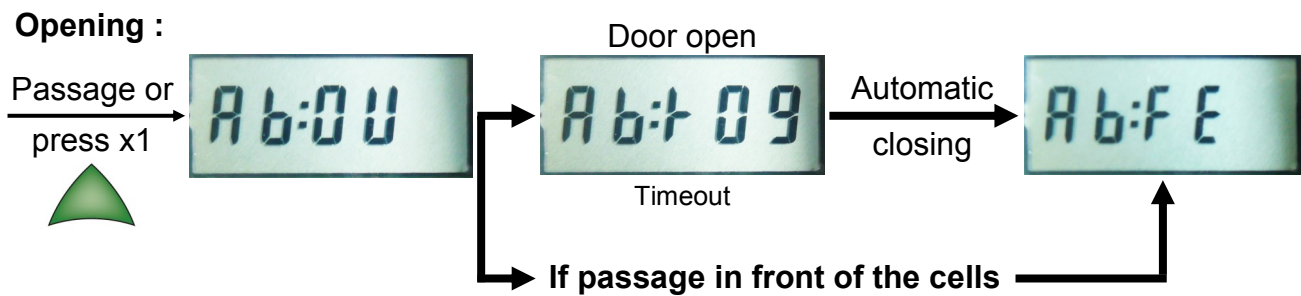

Note : Same as "Auto" automatic mode.

Note² : *If cells interruption during opening or timeout

↓
Timeout is taken back to 3 seconds before closing

Important : If screen display an error, see chapter : Operation errors.

Partial opening programming on the cabinet

(Pedestrian opening)
Operates in all modes except maintained pressure mode

► **Programming** : Door closed (example in impulse mode).

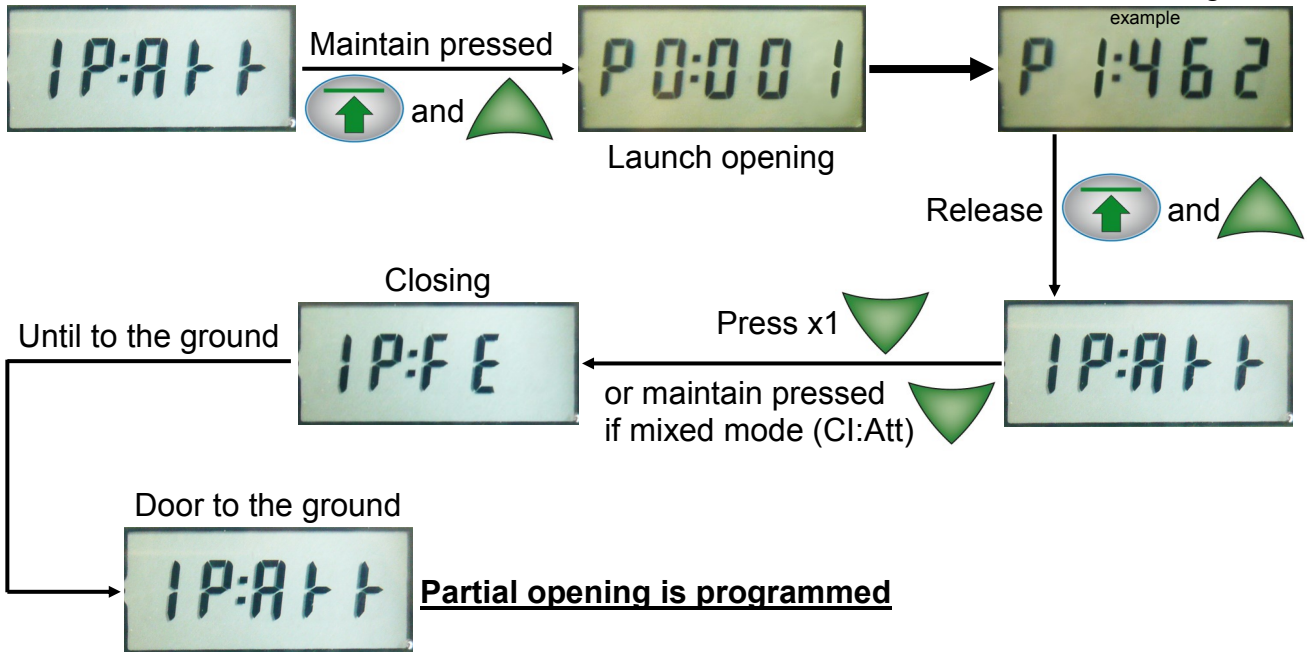

► **Operation** :

Press x1  → Opening until programmed height then operation identical to the corresponding mode.

➤ **Modification of the partial opening height :**

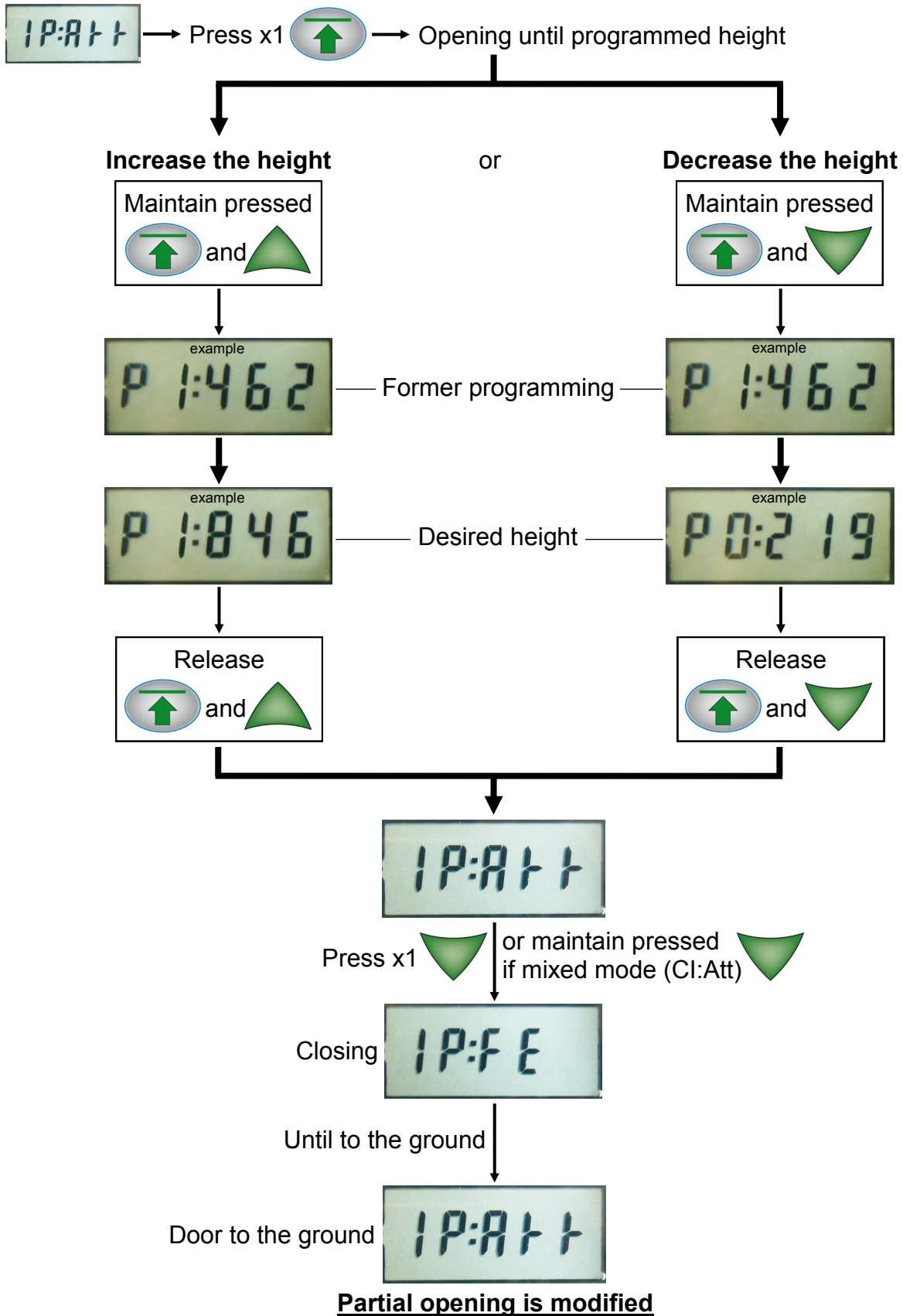

Important : If screen display an error, see chapter : Operation errors.

Memorization of the remote control

Operates in all modes except maintained pressure mode

Remark : If several remote controls, repeat the memorization of the total opening and the partial opening for each of them (32 remote controls max).

! It is not possible to program several buttons of the remote control for the same function (total or partial opening)

Total opening *(example in impulse mode)*

➤ **Memorization :** Door closed

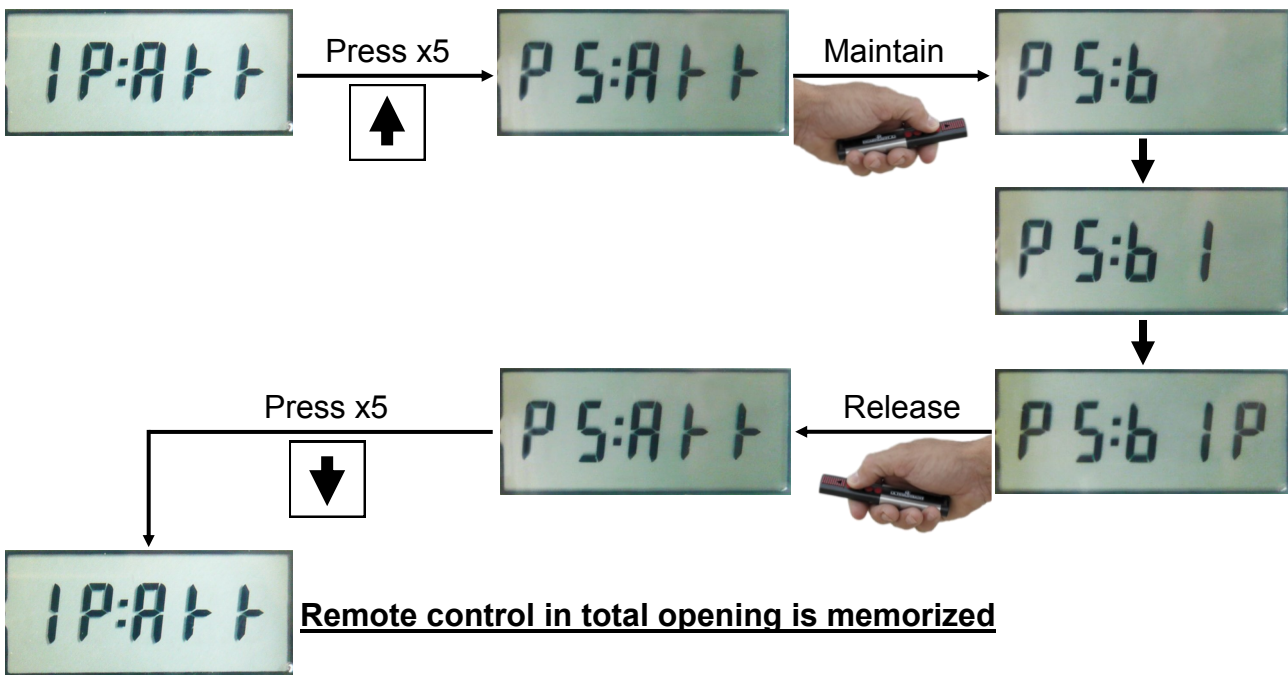

➤ **Operation :**



Note : Operation is different for each mode (see corresponding paragraph).

Important : If screen display an error, see chapter : Operation errors.

Partial opening *(example in impulse mode)*

Note : The memorization of the remote control in partial opening will not work until the programming of the partial opening has been achieved on the cabinet.

➤ **Memorization :** Door closed (choose another touch for partial opening).

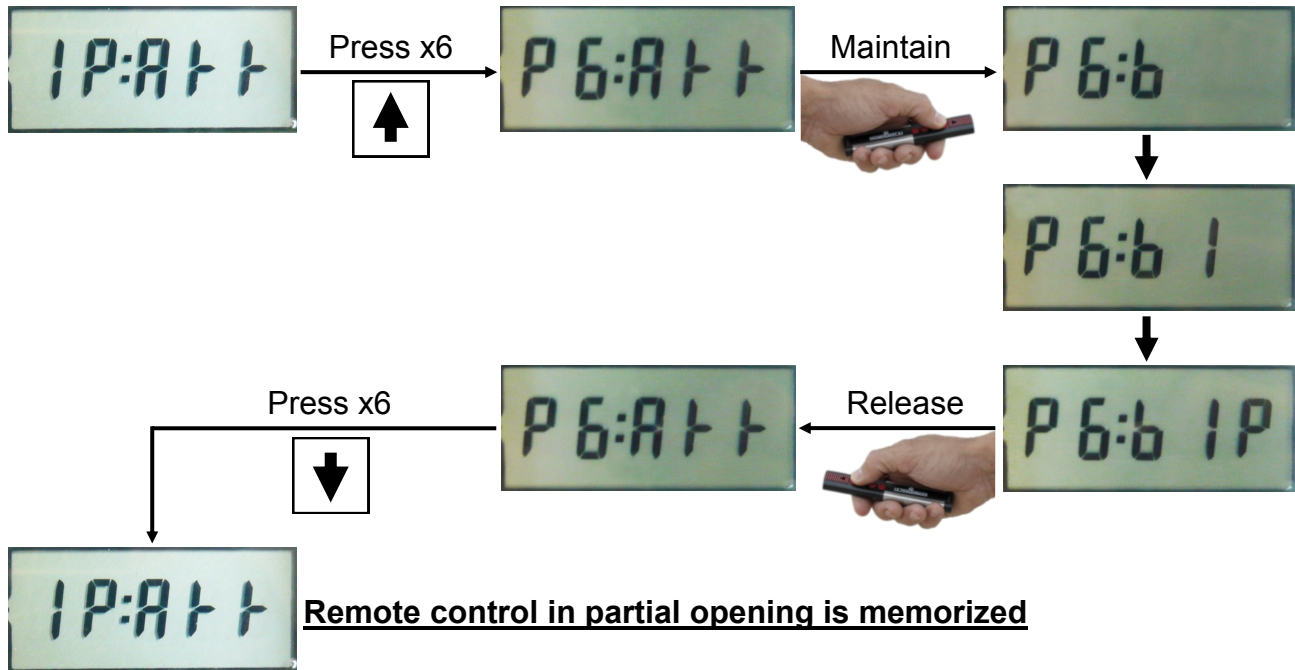

➤ **Operation and note :** identical to paragraph of total opening.

Important : If screen display an error, see chapter : Operation errors.

Number of remote controls *(in memory)*

➤ **Verification :** (example in impulse mode).

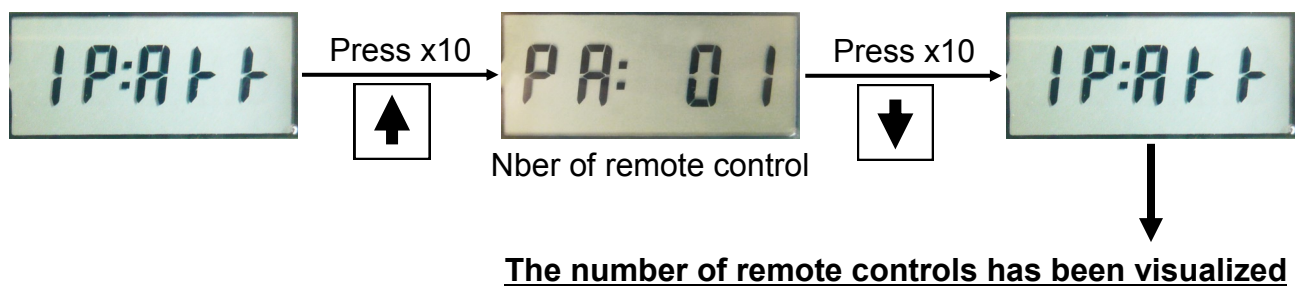

Erasing (of a touch of the remote control)

➤ **Deletion** : example in impulse mode.

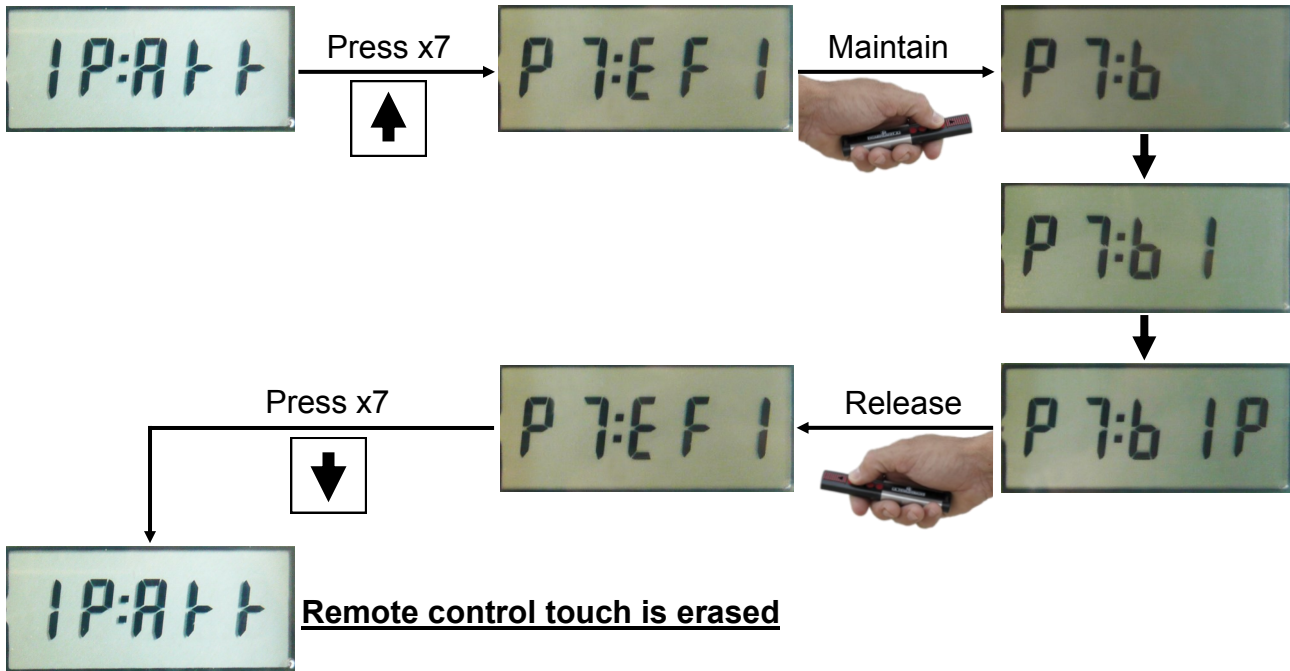

Note : To erase another touch from the remote control, start again steps.

Important : If screen display an error, see chapter : Operation errors.

Erasing (of all remote controls)

➤ **Total deletion** : example in impulse mode.

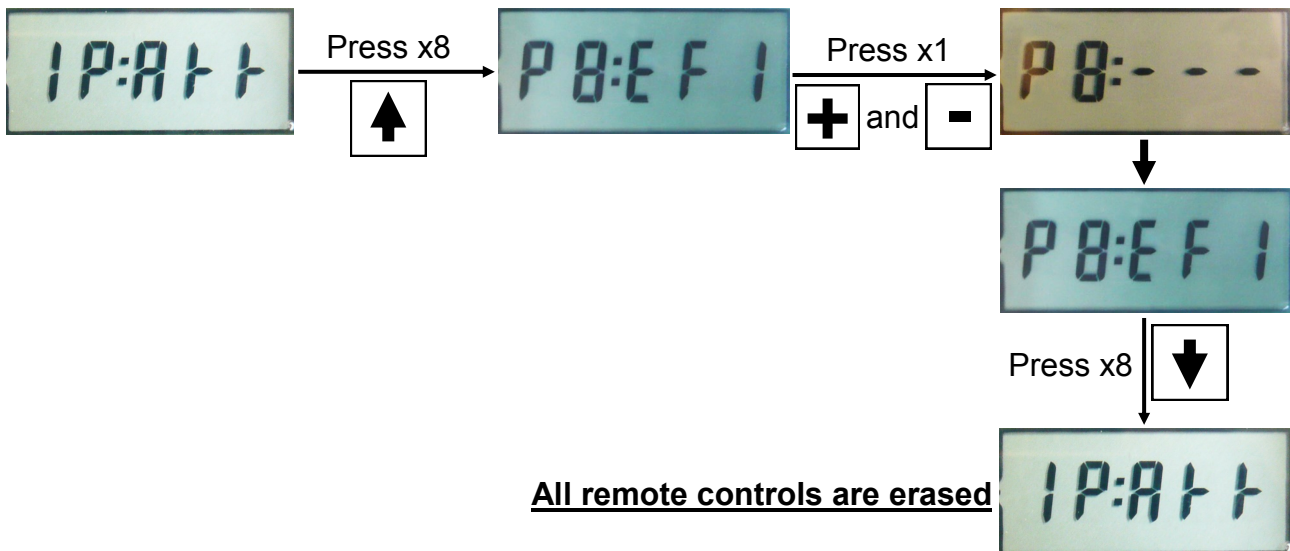

Reading the last 10 errors

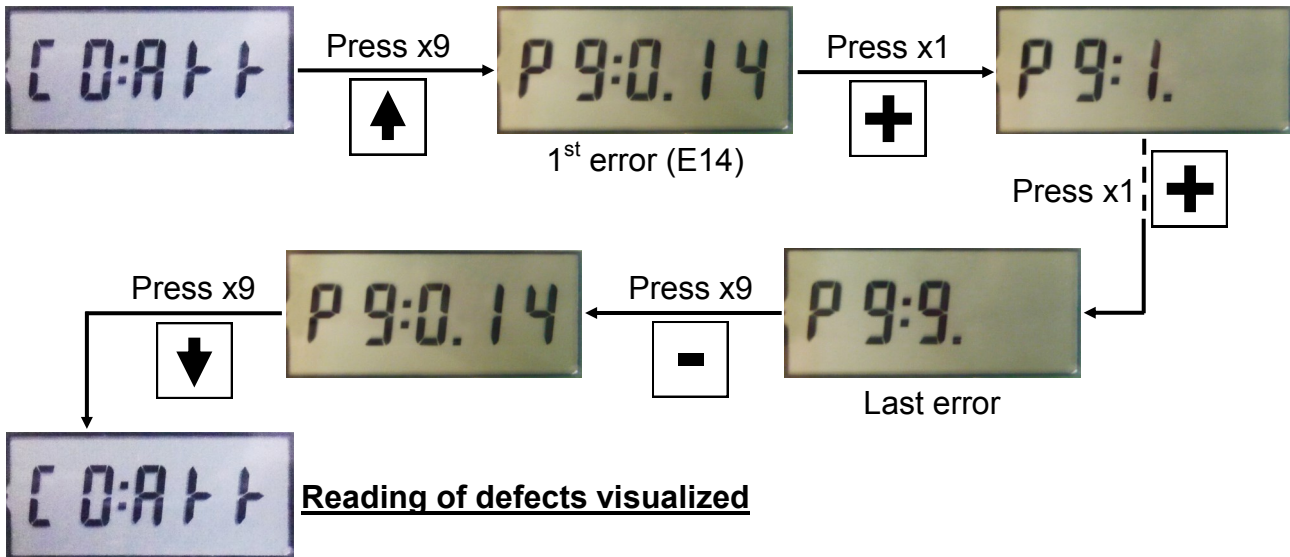

Important : If screen display an error, see chapter : Operation errors.

Reading (General cycle counter)

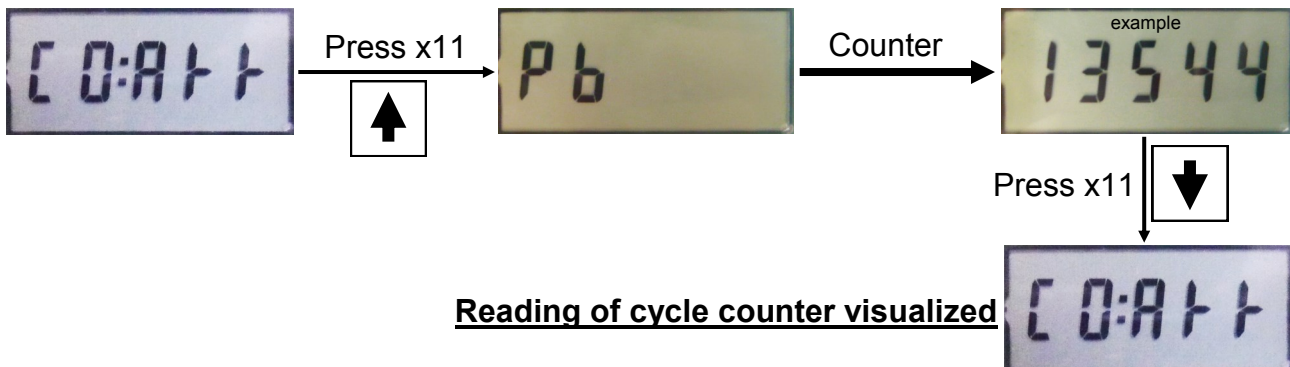

Reading or erasing (Temporary cycle counter)

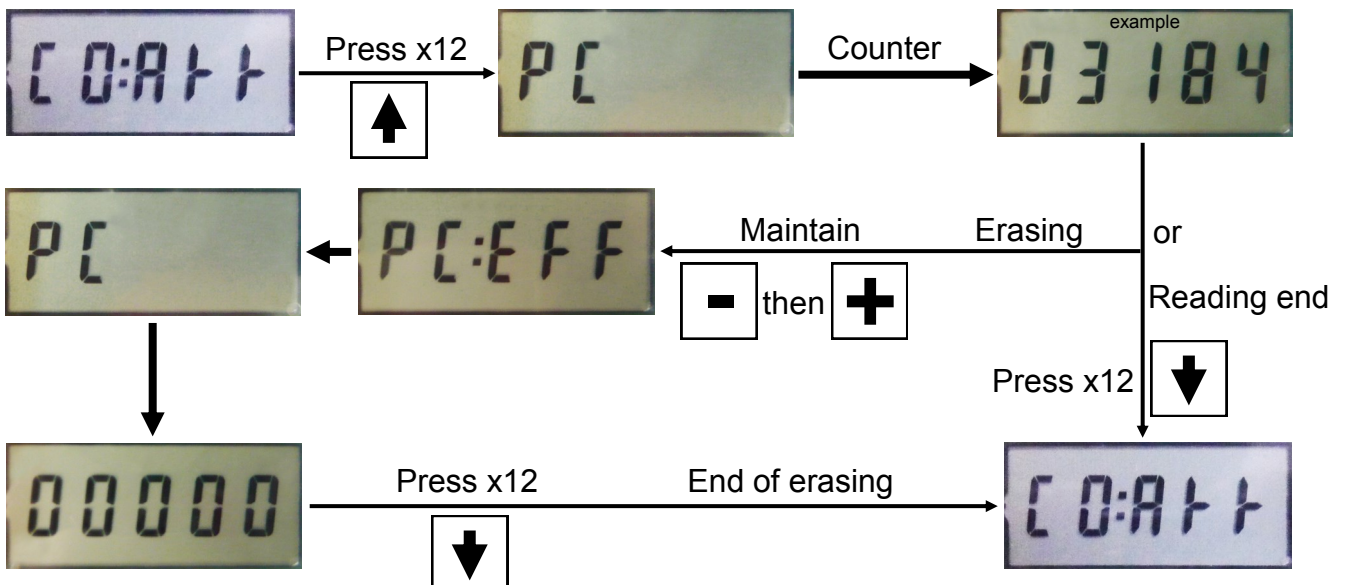

Connecting accessories

IMPORTANT :
 In the case of connection of a control member or safety device, it is imperative to perform an apprenticeship to make the entries 22/23/24/25/26 functional.
 See chapter : *Learning of the run.*

The control members shall be installed in view of the door but distant from moving parts and at a height of at least 1,5 m from the ground.

Maintained pressure operation

Only the control member requiring a maintained action must be installed and used.

2 switches box

Contacts 24V

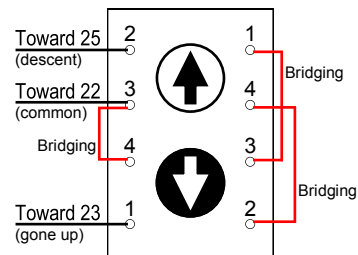
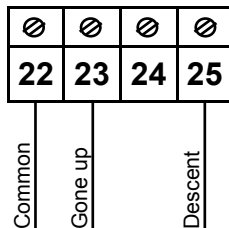

Wall-mounted 2 buttons box (BBA2)

Key box

Mandatory for maintained pressure mode in public area (EN 13241 + A2)

Contacts 24V

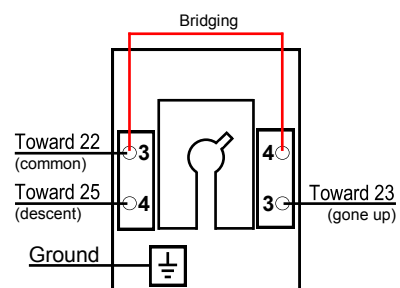
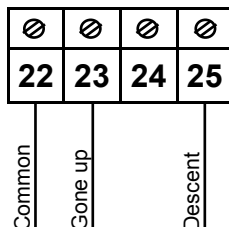

Wall-mounted/Built-in key box (BCA/BCE)

Mixed operation

3 switches box

 **Contacts 24V**

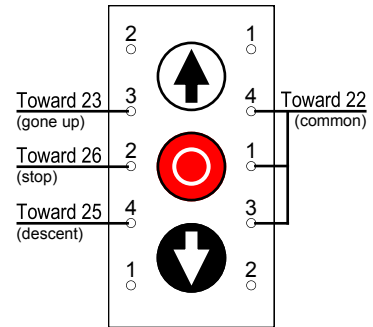
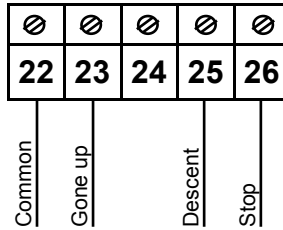

Wall-mounted 3 buttons box (BBA3)

Impulse or automatic operation

1 switch box

 **Contacts 24V**

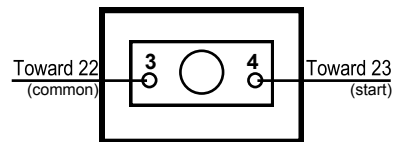
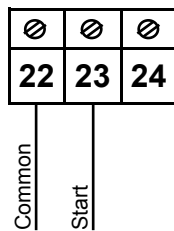

Wall-mounted button box (BBA)

Key box

 **Contacts 24V**

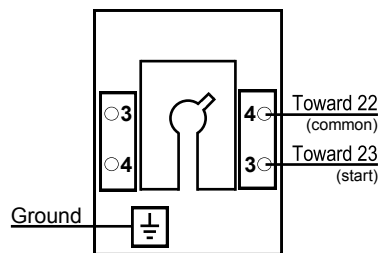
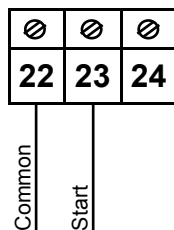

Wall-mounted/Built-in key box (BCA/BCE)

Partial opening operation

2 Boxes to 1 button (BBA)

Key box (BCE2/BCA1)

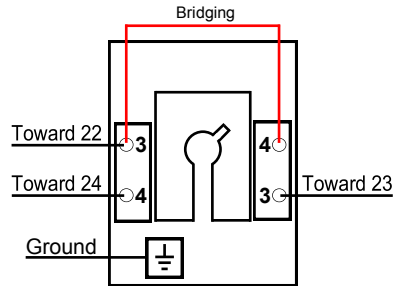
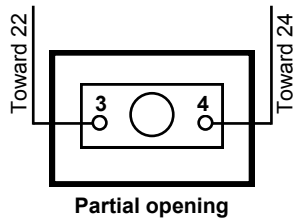
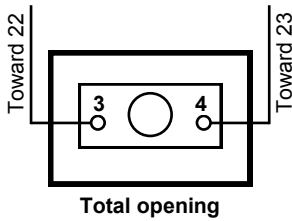
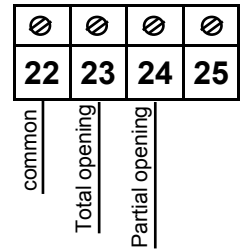
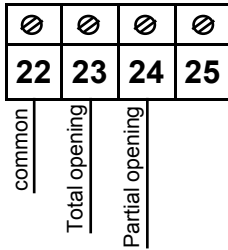

Cells emitting/receptors bass

Before connecting the cells, cut imperatively the power supply of the cabinet.

2 sets of cells mandatory in automatic or impulse modes
in public area out sight of the door (Standard EN 13241 + A2)

Remove the bridge between 19 and 21

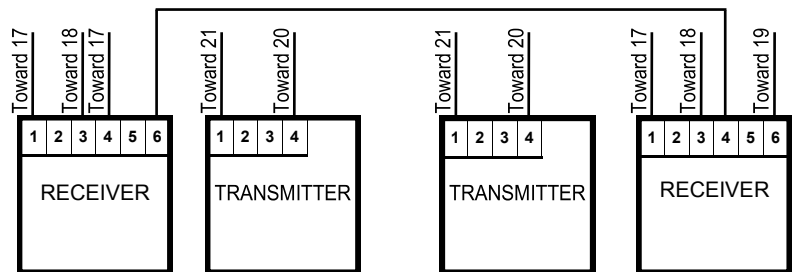
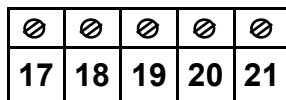

Interior cells

Exterior cells

Wicket door with opening safety *(option)*

⚠ Before connecting the contact radio, it is imperative to achieve learning for render the entries functional. See chapter : Learning of the run.

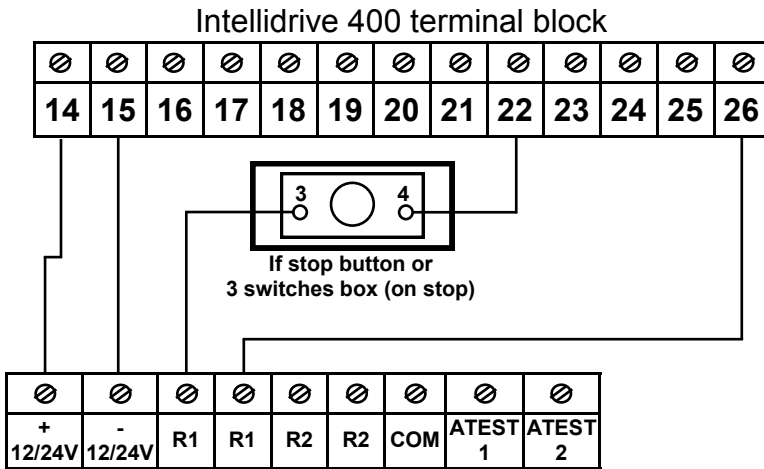

Important : Remove the bridge between 22 and 26.

Radio contact receiver terminal block

illuminating light *(option)*
2 maximum

230V and 250W maximum per light

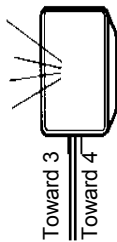

Orange flashing light *(option)*
2 maximum

24V and 15W maximum per light



Note : The connection of flashing lights automatically gives approximately 3 seconds notice.

Battery *(option)*

- Fix the battery at inside of cover.

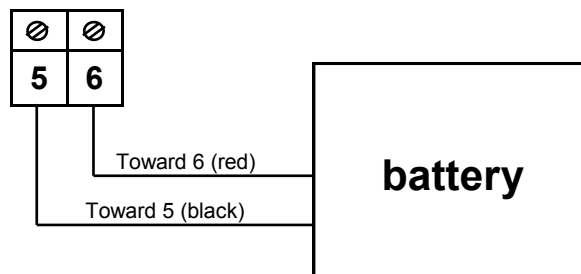

Warning :

- Battery plugged in at least 48 to 72 hours to obtain full charge.
- If you cut the power supply to the cabinet, the message IP:BAT (impulse/battery mode) must appear on the LCD screen.
- For more details on the operation of the battery mode, see the chapter "Battery option" in the user manual.

LED indication

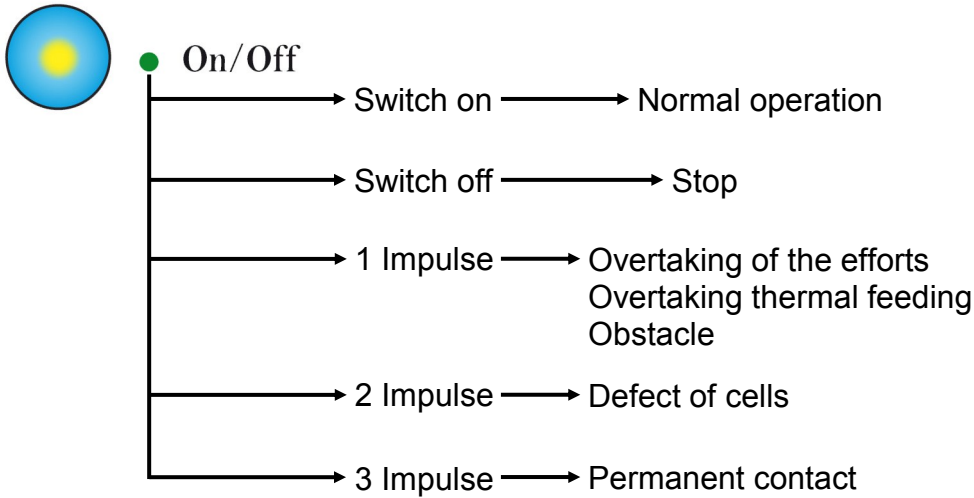

Come back "maintained pressure" mode from the other operating modes

► **Example** : IP = Impulse

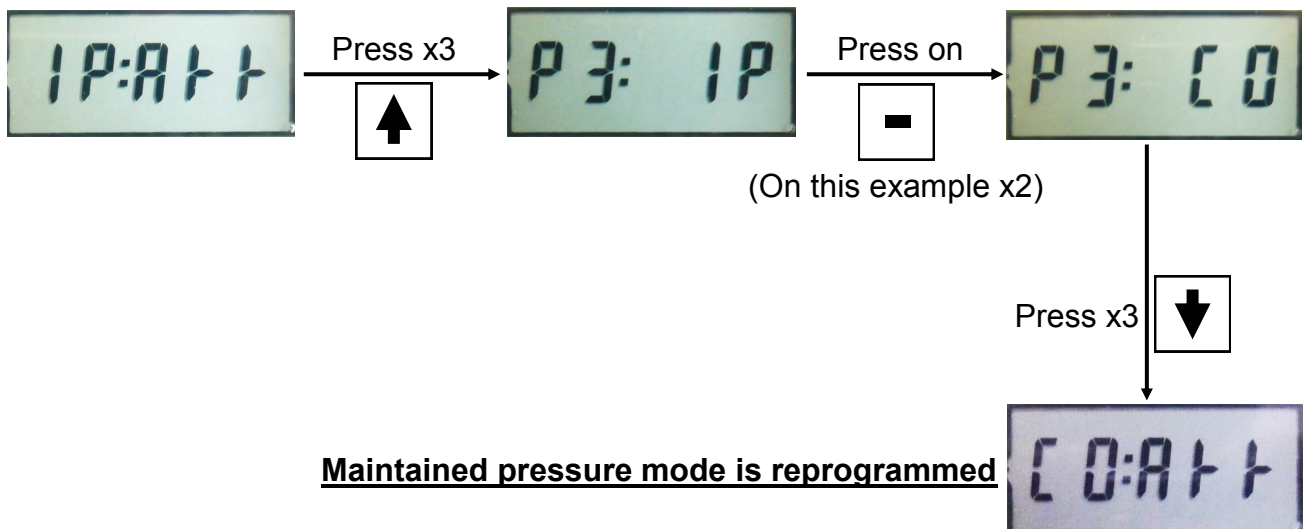

Summary of screen messages

Operating mode :

C0:	Maintained pressure mode	AS:	"Sequential" automatic mode
C1:	Mixed mode	AR:	"Auto" automatic mode
IP:	Impulse mode	Ab:	"Blocking" automatic mode

Operation of the door :

:A11	Awaiting	:bA1	Battery operation
:OU	Opening by command	:OU1	Opening by remote control
:FE	Closing by command	:FE1	Closing by remote control
:01	:05	, Etc...Timeout of reclosing	

Counter :

00000	Cycle counter	Pb	General cycle counter
:APP	Learning of the run	PC	Temporary cycle counter
P:0000	Learning of the efforts	PC:EFF	Ongoing of erasing the temporary cycle counter
P0:000	Learning of the partial opening		



Program information :

P1:	P2:	P3:	, Etc...Program
P1: 70	P1: 75	, Etc...Program 1, closing speed	
P4: 00	P4: 10	, Etc...Program 4, timeout of reclosing setting	
PA: 01	Program A, number of remote controls		
P9:0.	P9:1.	, Etc...Program 9, list of errors	
U2 - 15	Card number (example : 15)		

Remote control information :

:b IP	Programming remote control total or partial opening and deprogramming
:EF1	Erasing a touch from the impulse remote control
:- - -	Ongoing of erasing all remote controls

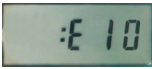
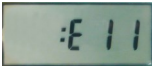
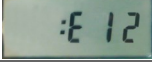
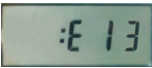
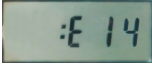
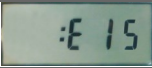
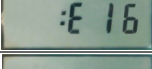
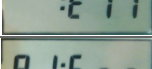
Operation errors

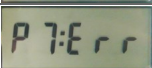
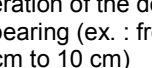
Display/Symptom	Cause	Remedy
	<ul style="list-style-type: none"> - Obscured cells - Misalignment of cells - Misconnection of cells or disconnected wires - Passage to automatic mode without having connected the mandatory cells 	<ul style="list-style-type: none"> - Remove the obstacle in the cell beam - Align cells face to face - Check cells connections - Connect the mandatory cells (EN 13241-1)
	<ul style="list-style-type: none"> - Bridge between terminals 19/21 and selection of operating mode AS or AA or Ab 	<ul style="list-style-type: none"> - Remove bridging between terminals 19 and 21 or change mode of operation
	<ul style="list-style-type: none"> - Defective cells (transmitter cut without receptor reaction) 	<ul style="list-style-type: none"> - Replace defective cells
	<ul style="list-style-type: none"> - Permanent contact on the entrance of control (terminals 22, 23 and 24) - STOP (terminals 22 and 26) activated 	<ul style="list-style-type: none"> - Check connections and operation of control devices - Check the STOP button and if applicable, the wicket door contact
	<ul style="list-style-type: none"> - Exceedance of authorized efforts (anti-lift/ anti-crushing) - Imbalance of the door (on or under offset) - Wicket door opening during operation - Hard spot during door operation - Poor learning of efforts - Power cut and return during operation - Return of current during battery mode operation (option) 	<ul style="list-style-type: none"> - Remove the obstacle - Relax or tender the springs - Close the wicket door - Suppress hard points - Redo learning of the run
	<ul style="list-style-type: none"> - Temperature limit reached (85°C) 	<ul style="list-style-type: none"> - Waiting for the temperature to drop
	<ul style="list-style-type: none"> - Blocking after 3 reopenings consecutive on the obstacle 	<ul style="list-style-type: none"> - Check manual operation of door
	<ul style="list-style-type: none"> - Learning not realized 	<ul style="list-style-type: none"> - Realized a Learning of the run
	<ul style="list-style-type: none"> - Touch of the remote control already memorized in total opening 	
	<ul style="list-style-type: none"> - Touch of the remote control already memorized in partial opening 	
	<ul style="list-style-type: none"> - Touch of the remote control already erased 	
Operation of the door by bearing (ex. : from 10 cm to 10 cm) or the motor does not work	<ul style="list-style-type: none"> - Misconnection of terminals 7, 8 and 9 - Misconnection to the motor - Cut-off or false contact problem - Motor connector disconnected 	<ul style="list-style-type: none"> - Check the connections conformity at terminals 7, 8 and 9 - Check the connection to the motor - Check the continuity of the wires - In case of a persistent anomaly, redo a learning of the run
Snap of the motor sprocket in end of the high or low stroke	<ul style="list-style-type: none"> - Cable of emergency maneuver not stretched enough 	<ul style="list-style-type: none"> - Tender the cable from the emergency maneuver (see paragraph : mounting the emergency maneuver)
The door stops in low part without display of errors	<ul style="list-style-type: none"> - The door is too offset - Lack of greasing of springs - Apron too tight on seals 	<ul style="list-style-type: none"> - Relax the springs - Grease the springs - Adjust the apron (roller supports)

Emergency maneuver

(power outage without battery option)

The green light of button On/Off is off.

- If the light is on, press On/Off 1 time to turn off the box.

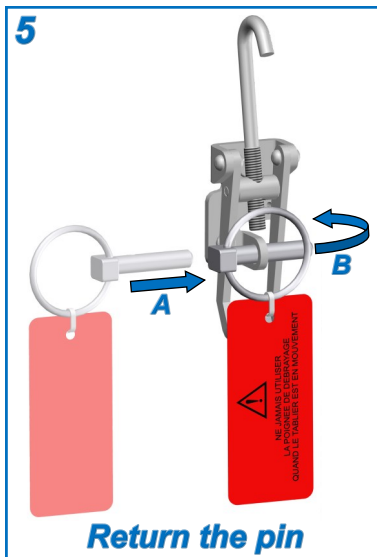
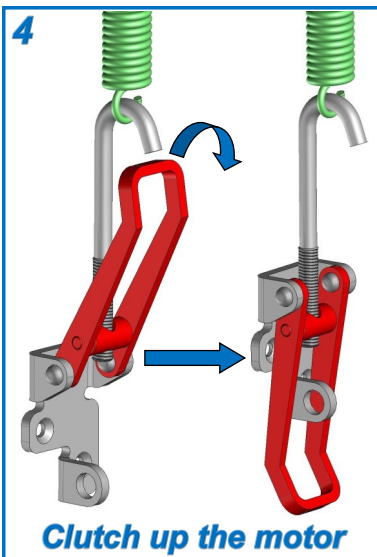
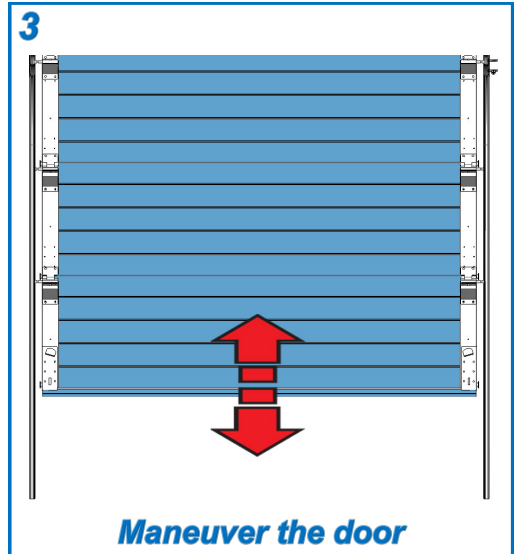
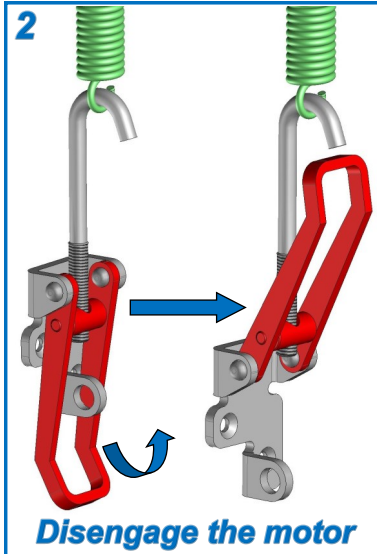
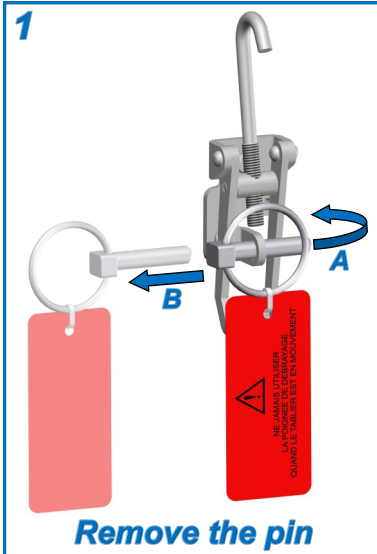

If **operation 4** is **major effort**, move the apron slightly to facilitate the interlocking of the motor.

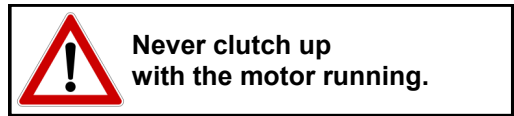

! If it is not a power outage, that the green light flashes and that a message error appears on the LCD screen, please refer to the operation errors.

Technical assistance contact

(Stamp of the installer)

