

# Installation and connection manual

No.1431

05/18

## Murax P110 Shutters and Dentel grille

## Operator E400 - E750 with CS110 Box

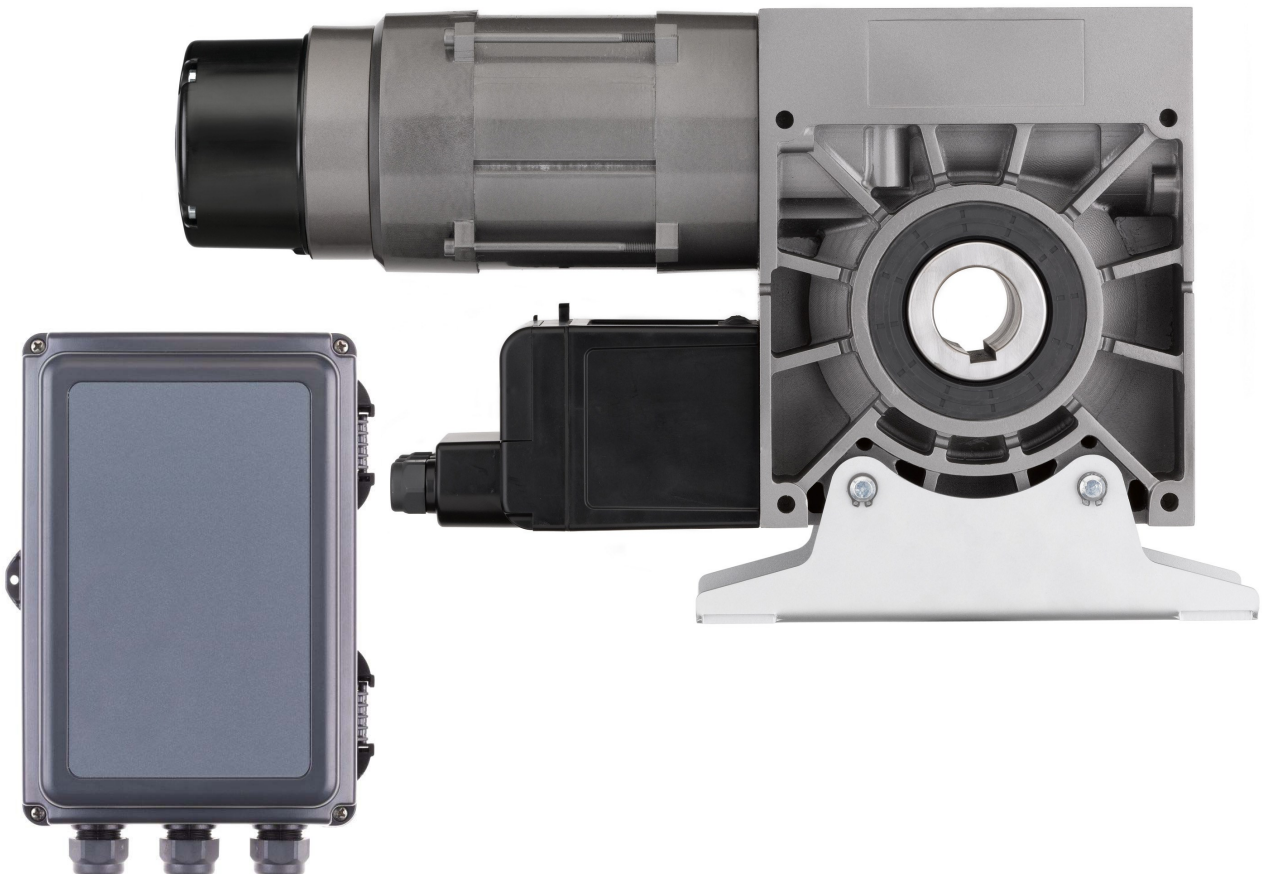

(Document reserved for installers)

# Contents

Equipment required for installation .....	p.2
Installation instructions .....	p.3
Information on the operators .....	p.4
Installing the guiding rails and the axle .....	p.5
Shutter installation principle .....	p.8
Assembling the Murax shutter .....	p.9
Assembling the Dentel shutter .....	p.12
Connecting the CS110 box .....	p.13
Connecting the operator .....	p.14
Setting the end positions .....	p.14
Sustained pressure operation .....	p.15
Combined operation (outside public areas) .....	p.16
Display and rectification of faults .....	p.17
Reinitializing factory settings .....	p.17
Finishes .....	p.18
In case of problems maneuvering the shutter .....	p.18
In case of incorrect functioning of the operator .....	p.18
Assembling the hoist on the E400 operator (Option).....	p.19
Assembling the hoist on the E750 operator (Option).....	p.20
Emergency operation using the crank or the hoist (Option) .....	p.21 or p.22

## Equipment required for installation

- |                     |                                      |
|---------------------|--------------------------------------|
| - Lifting equipment | - Flat wrenches: 8, 10, 15 and 17 mm |
| - Clamps            | - Hexagon keys: 5 mm                 |
| - Spirit level      | - Socket wrenches: 10, 15 and 17 mm  |
| - Plumb bob         | - Screwdriver                        |
| - Tape measure (5m) | - Grease and brush                   |
| - Hammer drill      | - Multi-grip pliers                  |

# Installation instructions



## **CAUTION!**

To ensure that this product is assembled, used and maintained in complete safety, it is important to follow the instructions provided in this document.

For everyone's safety, please observe the precautionary measures below.



- \* Before beginning the assembly, read this manual carefully.
- \* This closure must be installed by a professional technician.
- \* All the parts delivered are specifically sized for this product. Adding and/or using other parts may be detrimental to safety and may affect the product's warranty.
- \* Any modification or improvement of this closure must be compliant with the standard EN 13241 + A2. In this case, a "modification/transformation" file must be created by the installer as per the standard EN 12635 annex C.
- \* Considerable force is exerted in the case of a shutter or a grille. This work must therefore be carried out in accordance with the safety instructions. Use the appropriate tools to install these products. Ensure that the work is carried out on a stable floor.
- \* Ensure that the assembly area is adequately lit, clear, clean and clearly marked out.
- \* Ensure that no other people are present at the assembly site apart from the installers. Non-authorized persons (children for example!) who are present at the site risk injury during assembly.
- \* All the components of this closure must be installed in compliance with the installation instructions provided in this manual.
- \* All the requirements of the standards EN 13241 + A2 must be met and verified if necessary.

### **Max. locking torque:**

- Assembly screw: **10 Nm**
- Shutter clip screw: **12 Nm**

### **Min. working load per attachment point:**

- Plates: **300 daN**
- Guiding rails: **40 daN**

**Please note:** If installing on an iron structure, the guiding rails and plates can be welded to the building. In this case, a cord of approximately 50 mm must be attached to each side, roughly 800 mm apart.

## Information on the operators

	E400 Operator		E750 Operator
Output torque (Nm)	420		750
Output rotation speed (min -1)	12		10
Operator power (Kw)	1.1		1.4
Operating voltage (V)	230/3~	400/3~	400/3~
Power supply frequency (Hz)	50		
Control circuit voltage (V)	24		
Nominal motor current (A)	8.83	5.1	3.9
Operator continuous operation time (%)	60		25
Power supply under your responsibility (mm <sup>2</sup> )	5 x 1.5		
Protection under your responsibility (A)	10		
Protection class (IP)	54		
Temperature range (°C)	-20 / +60		
Continuous sound pressure level (dB (A))	< 70		
Unit weight (kg)	27		29

# Installing the guiding rails and the axle

 **The clearances for the hurricane slides and the noise reduction clips vary, refer to the corresponding manual which is included in the accessory pack.**

End-slat	
The inner clearance on each side must be observed in accordance with the depth of the guiding rail	
Bottom clearance of guiding rail	Depth of guiding rail
8 mm	40 / 60 mm
8 mm	80 / 100 mm

Intermediate slats or Corrugated tubes	
The inner clearance on each side must be observed in accordance with the depth of the guiding rail	
Bottom clearance of guiding rail	Depth of guiding rail
8 mm	40 / 60 mm
12 mm	80 / 100 mm

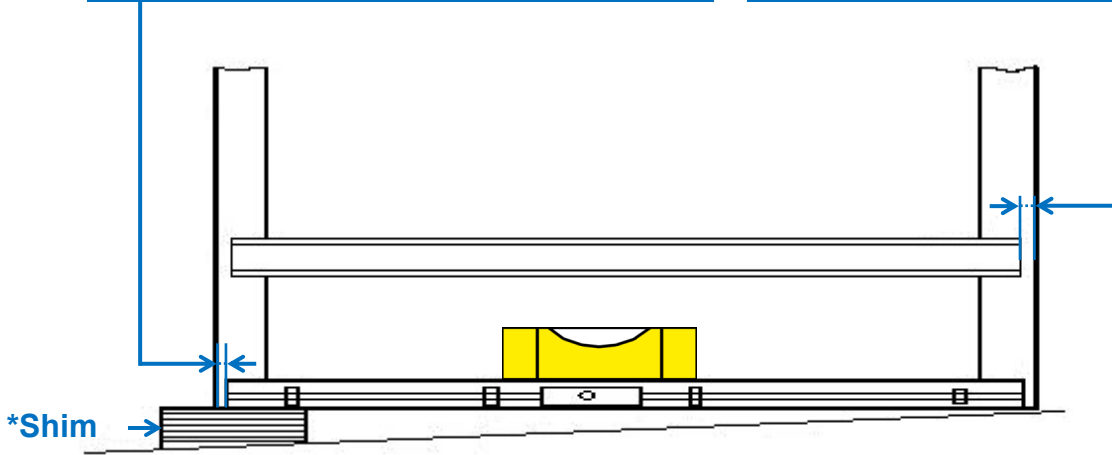

 **Operator side:** It is essential to leave a space of 180 mm at the back of the guiding rail to accommodate the operator.  
**Opposite side to the operator:** It is essential to leave a space of 100 mm at the back of the guiding rail to install the bearing and the clamping washer

- 1 - Provisionally attach the guiding rails using the clamps.
  - Position the end-slat horizontally (a shim may potentially be needed at the bottom of the guiding rail\*), ensuring that the clearance is respected.
  - Check that the guiding rails are plumb.
  - Permanently attach the guiding rails and the upper section of the winding plate.
  
- 2 - Opposite side to the operator (OO):
  - Attach the reinforcement brackets to the winding plate with the screws FZ M8x20 ZN and the nuts HE M8 ZN.
  - Attach the assembly to the wall using the brackets (pins and screws not provided)

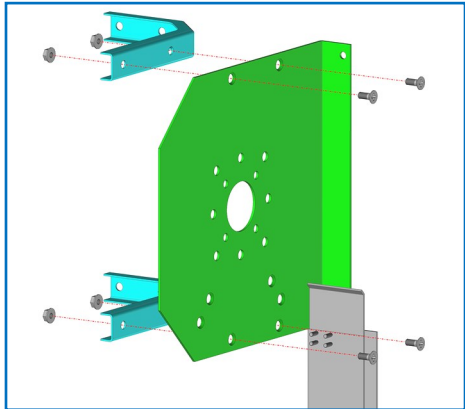
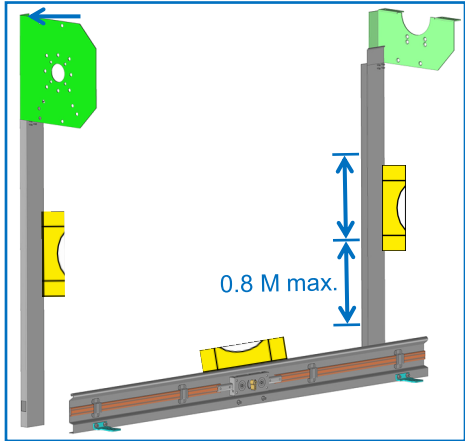

- 3** - Operator side (OS):  
 - Disassemble the upper half winding plate.

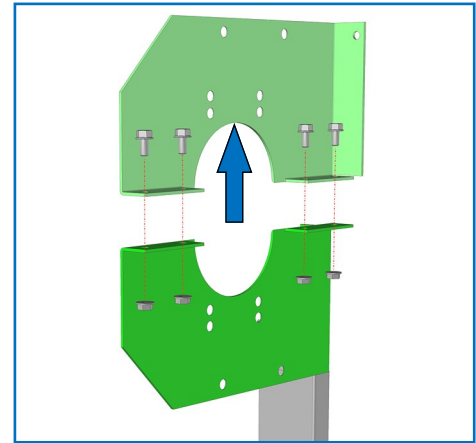

**3**

- 4** - Operator side (OS):

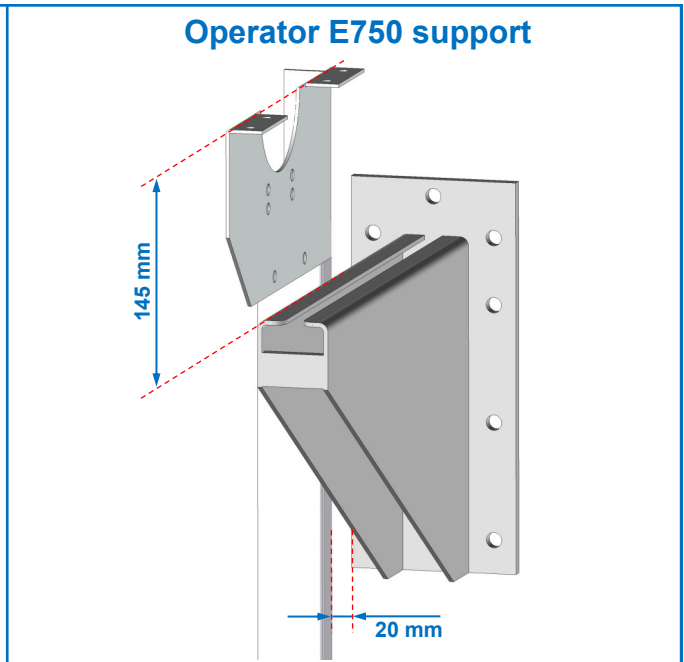
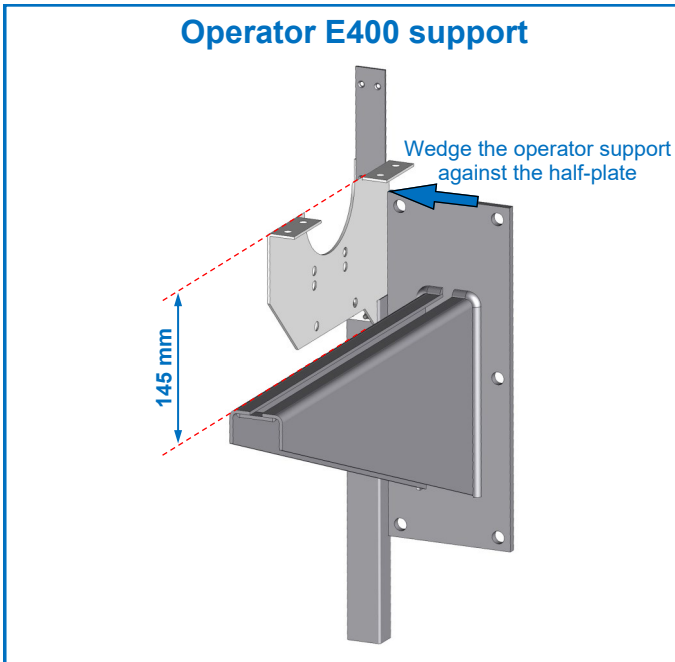

**4**

Firmly attach the support to the wall with the steel pins and 6 screws TH M14 (pins and screws not provided).

Firmly attach the support to the wall with the steel pins and 10 screws TH M12 (pins and screws not provided).



**The weight of the shutter is carried by the winding plate (OS) and the operator support; therefore, the support must be attached to the wall very carefully.**

**5 - Installing the shaft**

- Fit the bearing onto the shaft, screw the clamping washer to the end of the shaft with the FHC M8x16 screw with threadlock.
- On the operator side, position the keyed shaft on the lower half-plate.
- On the opposite side, screw the bearing to the plate with the corresponding screws, inserting shims in between them.

**Opposite side to the operator (OO)**

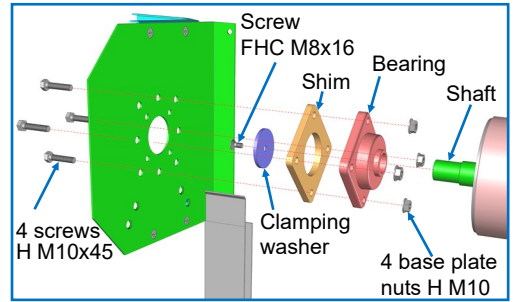

5

**6 - Installing the operator** Fit the operator onto the keyed shaft.

**Operator side (OS)**

**! The axle must be parallel with the header and the keyed shaft must be centered on the plate.**

Position the operator on its support and attach it with 2 bolts M12x45 and 4 washers of 12 mm. Reassemble the upper half winding plate and attach it to the wall.

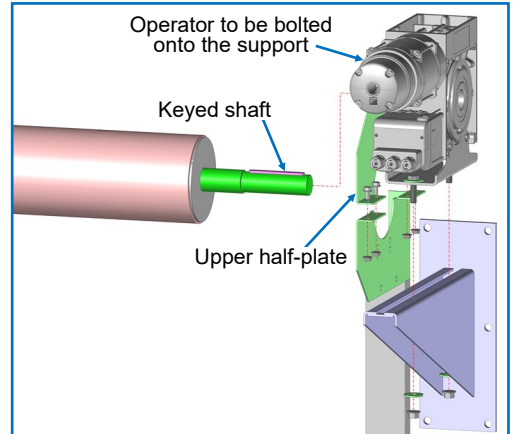

6

**! The front plates must remain parallel throughout the entire operation, so use additional supports (not provided).**

**7 - Once the structure is assembled, check**

**Opposite side to the operator (OO)**

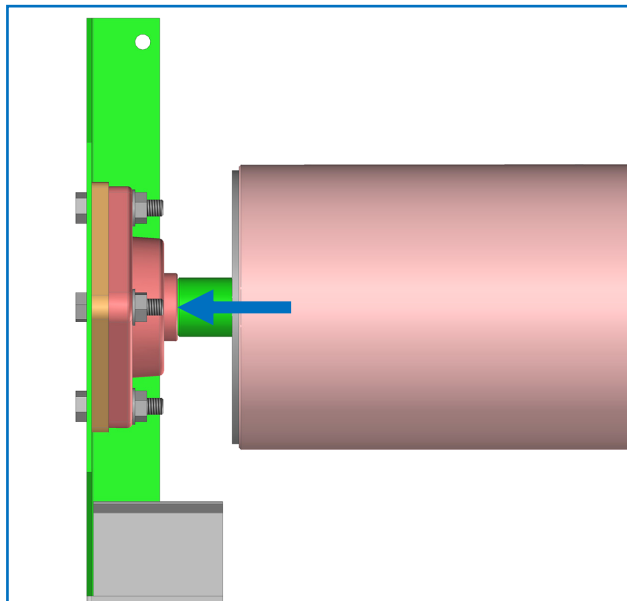

Shoulder abuts the bearing

**Operator side (OS)**

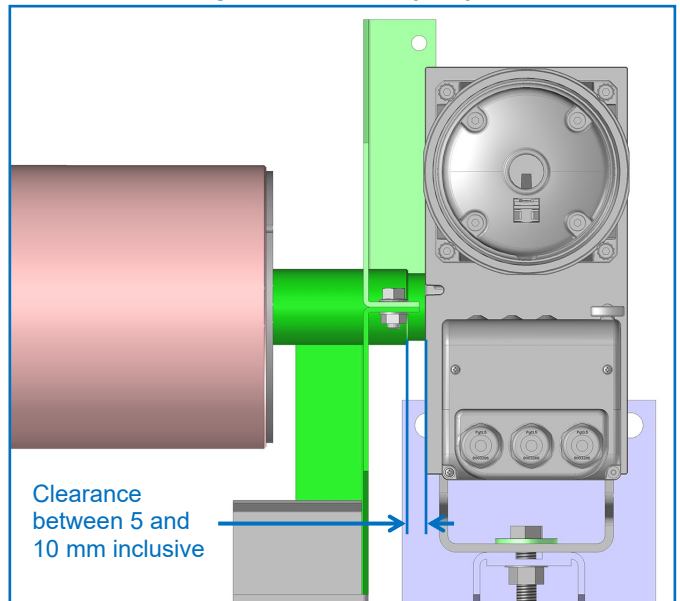

Clearance between 5 and 10 mm inclusive

Between the shoulder and the operator

7

# Shutter installation principle

## Rolling direction

### SOLID OR MICROPERFORATED MURAX SHUTTER

A Microperforated shutter always requires 3 full roller slats in the upper section

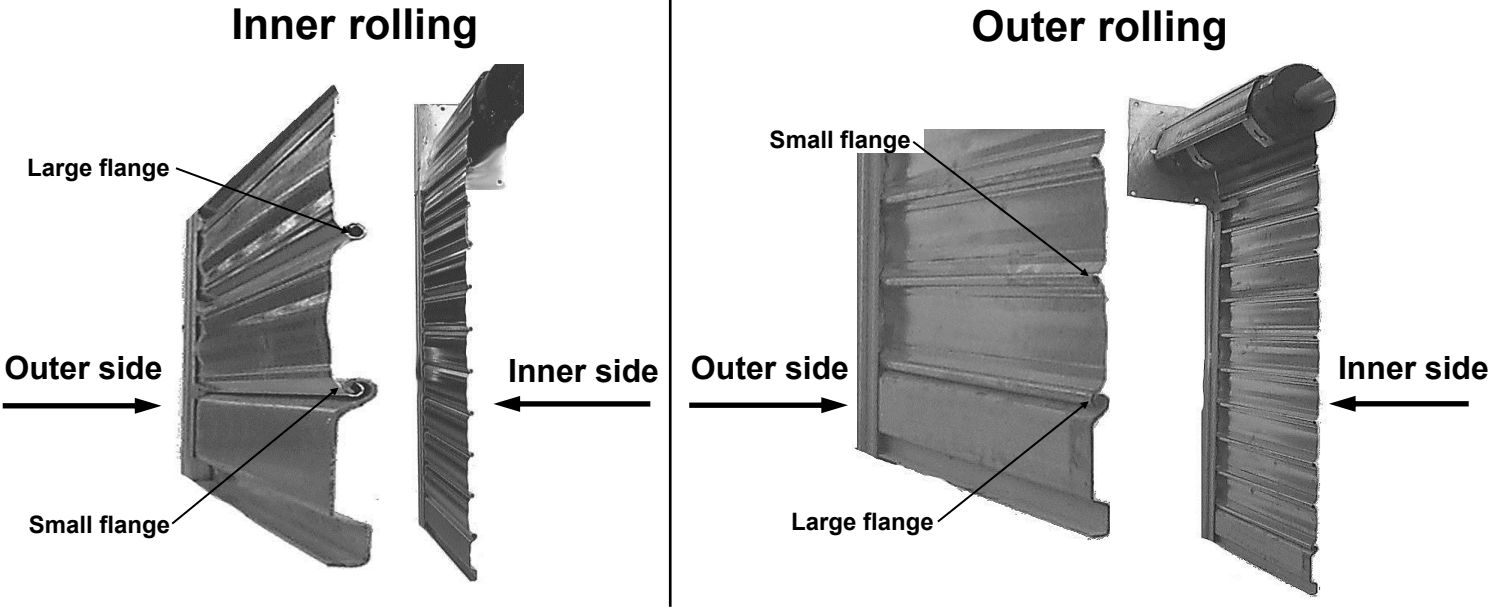

### DENTEL SHUTTER

A Dentel shutter always requires 3 full roller slats in the upper section

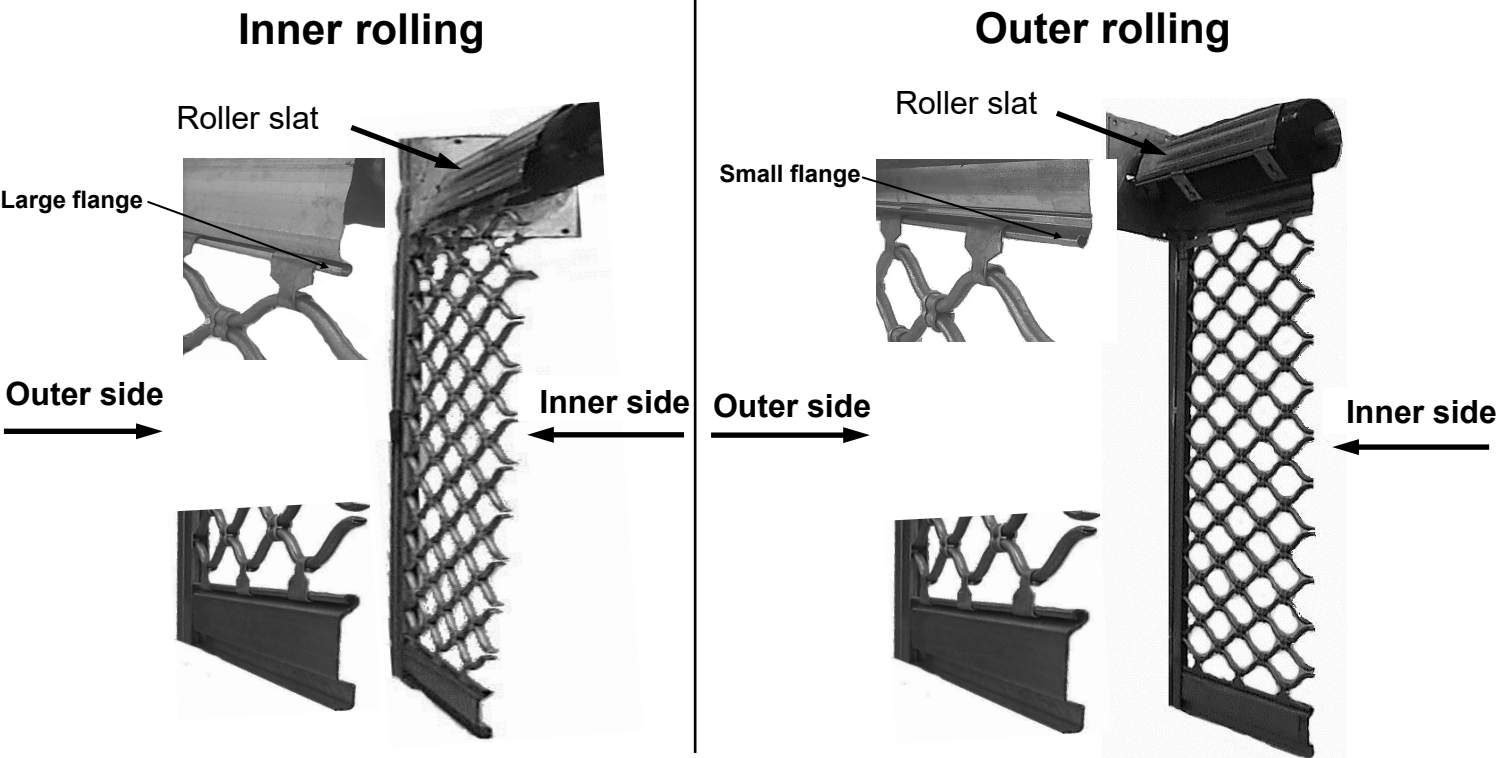



# Assembling the Murax shutter

**The height and the rolling of the shutter are calculated with a precise number of slats. All the slats provided must be installed.**

How the shutter is assembled depends on the space available on the assembly site at the back of the guiding rails.

## **Case No.1: You have plenty of space**

You have, on one side at least, a length longer than the length of the slats  
(for example: installation on the facade of a building)

1 - Assemble (roughly) a meter's length of the shutter on the floor using the shutter clips.

**The rolling direction**

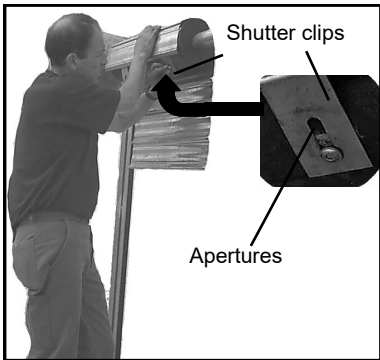

2 - Attach the shutter to the axle, letting the slats hang outside of the guiding rails. ①

**Before fully tightening the clamp screws, ensure that the screw heads are not touching the slat flange during rolling. If so, adjust all the clips so that they are at the same distance using the apertures.**

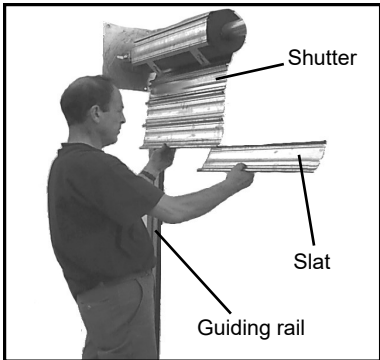

3 - Then, insert each slat from the side until the end-slat. ② ③

- Align the ends of the slats.

**If using hurricane end-pieces refer to the corresponding manual for the order of slats with end-pieces.**

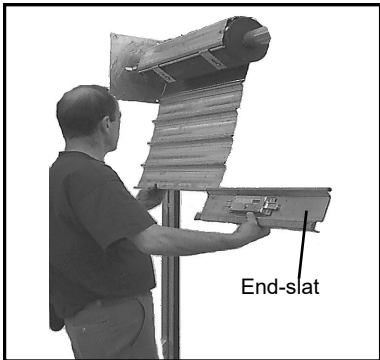

4 - Roll the shutter above the start curves.  
- Unroll the shutter in the guiding rails. ④

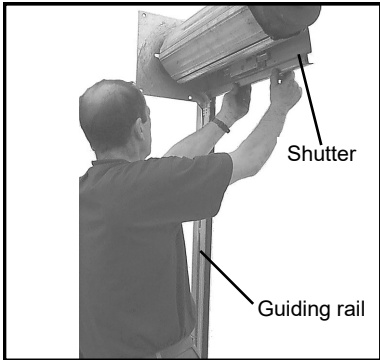

5 - Lower the shutter while checking that the slats are aligned.

6 - Remember to adjust the start curves.

## Case No.2: You do not have any space

You do not have any space at the back of the guiding rails  
(for example, installation in a corridor)

- 1 - Create the shutter by threading the slats together, without forgetting the clips. ①

**! The rolling direction**

- 2 - Roll the assembled shutter starting from the clips and moving towards the end-slat. ①
- 3 - Lift the shutter up to the tube using a hoist or an alternative lifting system.

**! To avoid scratching the slats while unrolling them, ensure that the axle is protected (e.g. with a box, etc.).**

- Unroll the shutter in the guiding rails starting from the end-slat. ②

- 4 - Slide each clip into place until it is opposite its corresponding hole. ③

- 5 - Attach the shutter to the tube using the clips. ④

**! Before fully tightening the clamp screws, ensure that the screw heads are not touching any of the slat flange during rolling. If so, adjust all the clips so that they are at the same distance using the apertures.**

- 6- Remember to adjust the start curves. ⑤

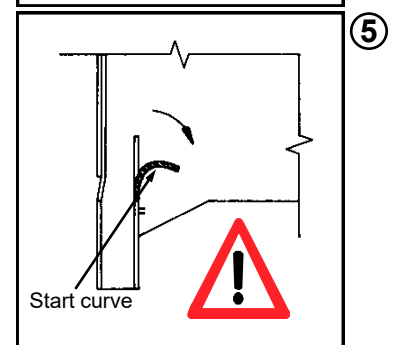
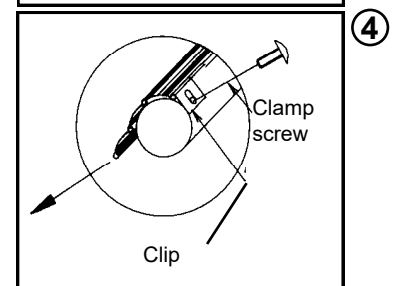
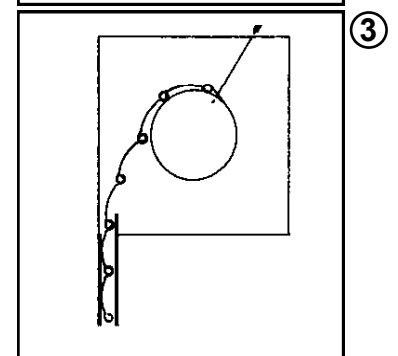
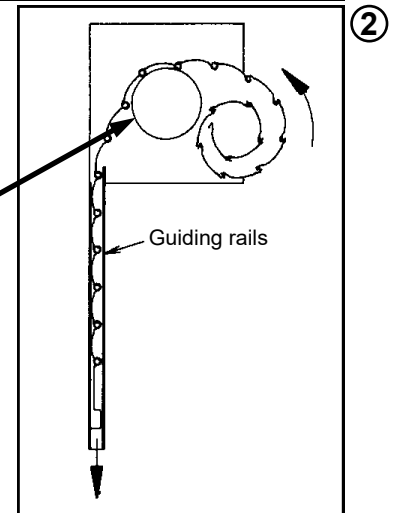
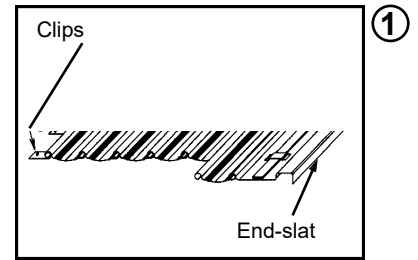

### **Case No.3: You do not have enough space**

You do not have enough space inside and the board is not very thick  
(for example: Installation inside a building with small reservations)



The rolling direction

- 1 - Assemble 12 to 15 slats on the axle outside of the guiding rails.
- 2 - Position them to the side of the assembled part of the shutter.
- 3 - Slide on the slats one by one from the outside until the end-slat.
- 4 - Reposition the shutter behind the guiding rails.
- 5 - Align the ends of the slats.
- 6 - Raise the shutter and insert the end-slat in the guiding rails.
- 7 - Lower the shutter checking that the slats pass through the guiding rails.
- 8- Remember to adjust the start curves.

# Assembling the Dentel shutter

1 - Insert the end-slat into the bottom clips. ①

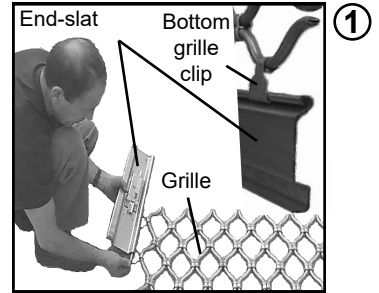

2 - Insert the 3 full slats into the top clips. ②

**! The rolling direction**

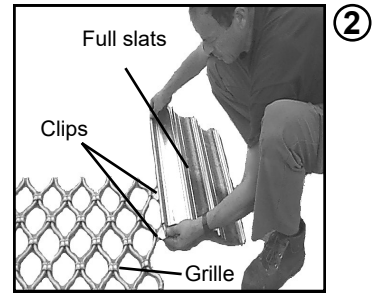

3 - Insert the shutter clips into the top slat. ③

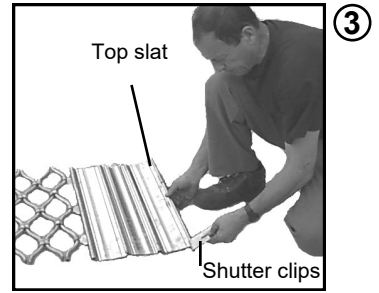

4 - Attach at least 2 hoists to the wall above the axle.  
 - Attach the hoists to the grille 1 m above the shutter.  
 - Mount the grille using the hoists and position the slats around the axle. ④

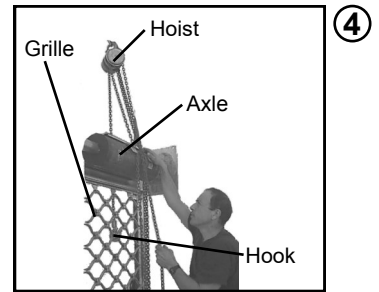

5 - Slide each clip until it is opposite its corresponding hole.  
 - Screw the shutter clips to the axle using the screws HC M8x16. ⑤

**! Before fully tightening the clamp screws, ensure that the screw heads are not touching the slat flange during rolling. If so, adjust all the clips so that they are at the same distance using the apertures.**

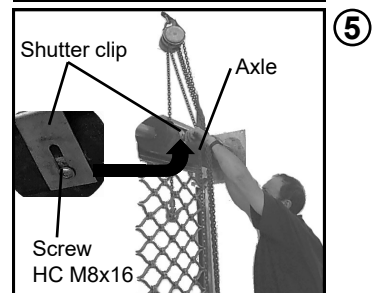

6 - Roll the shutter above the start curves  
 Unroll the shutter in the guiding rails. ⑥

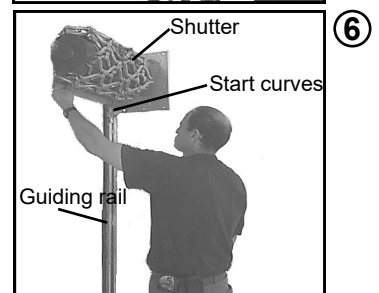

7 - Remember to adjust the start curves.

# Connecting the CS110 box

**⚠ The fixed controls must be installed within sight of the door but away from any moving parts and at a height of at least 1.5 m from the floor.**

**⚠ Use one switch for a single operator. It is completely prohibited to order several operators with a single monopolar switch.**

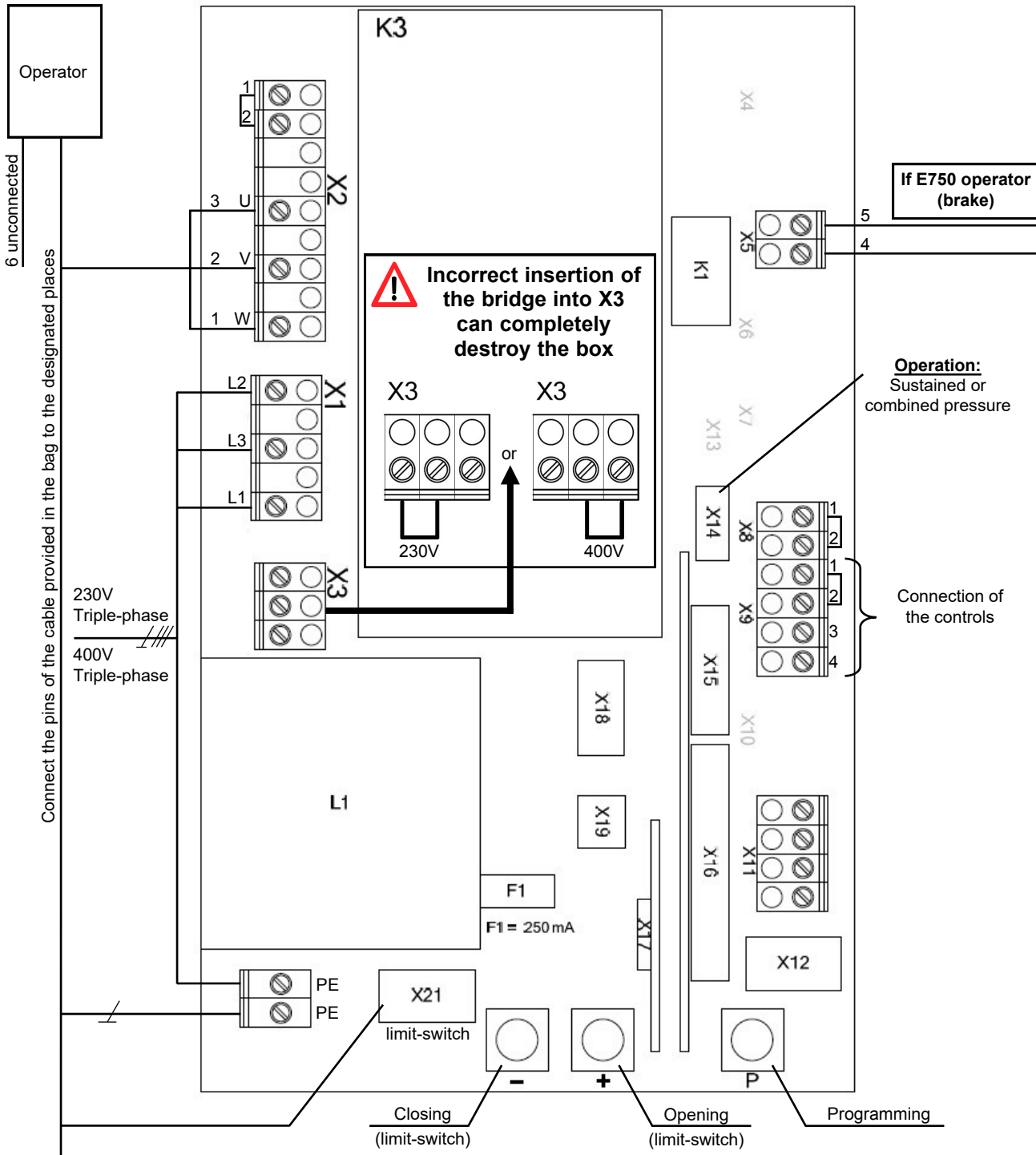

Ensure the power line is protected using an upstream differential circuit-breaker.

Ensure that in close proximity to the operator, there is:

- A thermal protection device for the operator
- A power cut-off system, which is accessible to the user

## Connecting the operator

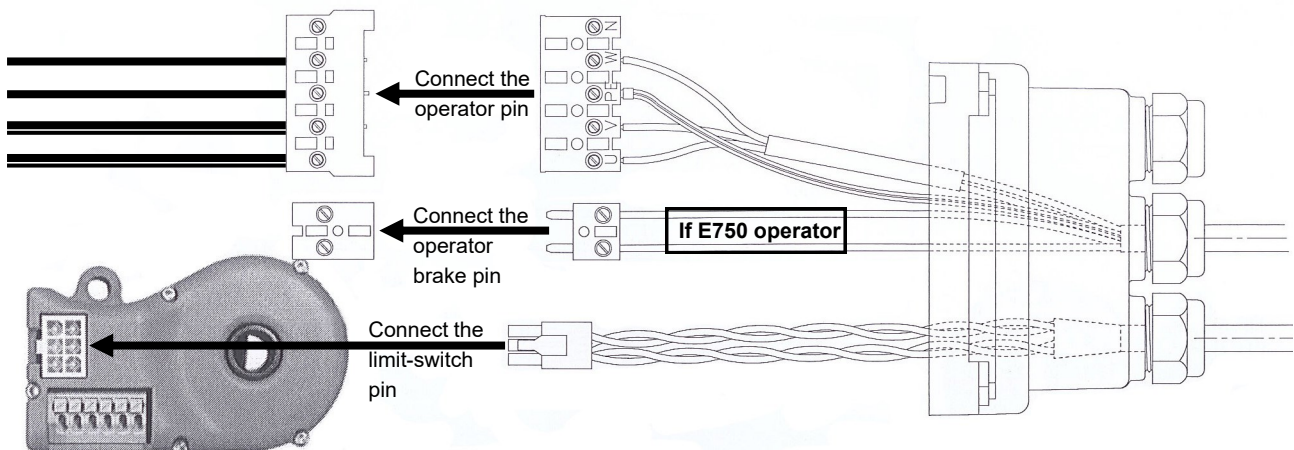

## Setting the end positions

### On the bearing plate of the box:

- Press and hold down the **P** key (programming) **for 5 seconds**, the red **LED** will flash slowly.
- **Setting the top end position**  
Open the door by pressing the **+** key (opening).



**If the door does not rise up, change the rotation direction of the operator by pressing the + and - keys for 5 seconds (the red LED flashes quickly) or by switching the U and V wires on the X2 terminal.**

Move the door to the final opening position required (adjust with the - key (closing) or + key (opening), if necessary).

Record the **final position** by pressing the **P** and **+** keys at the same time.

The red **LED** will flash quickly for **1 second**.

### **- Setting the bottom end position:**

Close the door by pressing the - key (closing)

Move the door to the final opening position required (adjust with the - key (closing) or + key (opening), if necessary).

Record the **final position** by pressing the **P** and **+** keys at the same time.

The red **LED** will flash quickly for **1 second**.

The end position settings will disappear automatically (wait 10 seconds), the red **LED will switch off**.

# Sustained pressure operation

-  - Set the final positions (end positions) before selecting the operating mode.
- Only the control requiring sustained action should be installed and used.

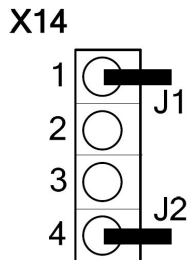

### On the bearing plate of the box:

Place the cable clips as indicated opposite.

### Emergency stop

It is possible to connect an emergency stop device.



### Connection of the controls to the X9 terminal



Do not remove the bridge between 1 and 2 in X9

## Button box (BBA1/BBE1)

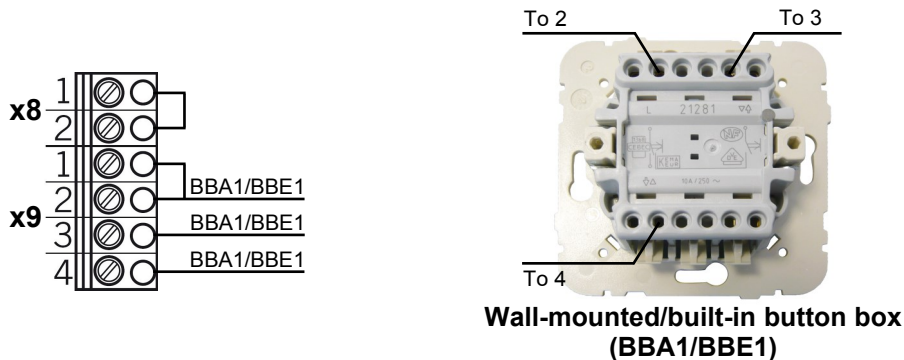

## Button box (BBA2)

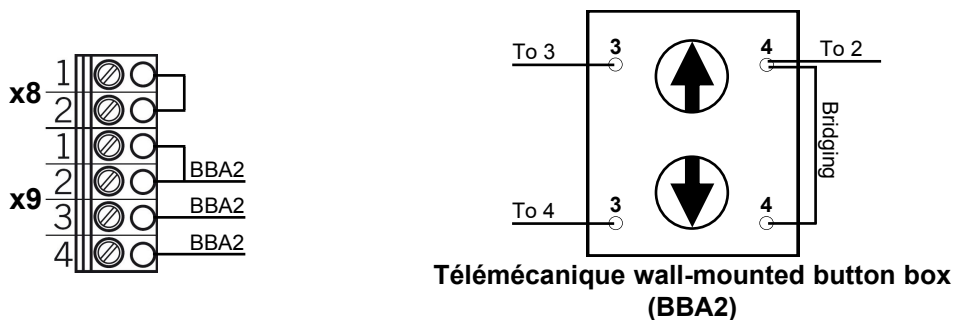

## Key switch box (BCA/BCE)

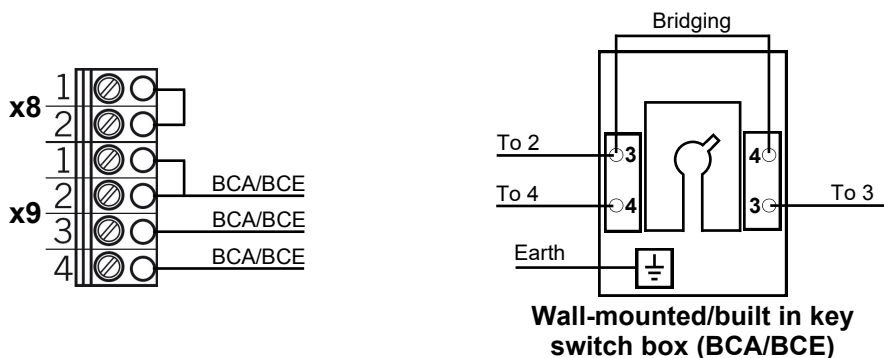

# Combined operation (outside public areas)

## Pulse ascent - Sustained descent



- Set the final positions (end positions) before selecting the operating mode.

X14

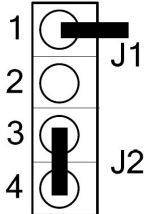

### On the bearing plate of the box:

Place the cable clips as indicated opposite.

### Emergency stop

It is possible to connect an emergency stop device.

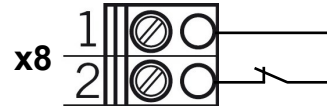

### Connection of the controls to the X9 terminal



Remove the bridge between 1 and 2 in X9

## Button box (BBA3) + Micro switch

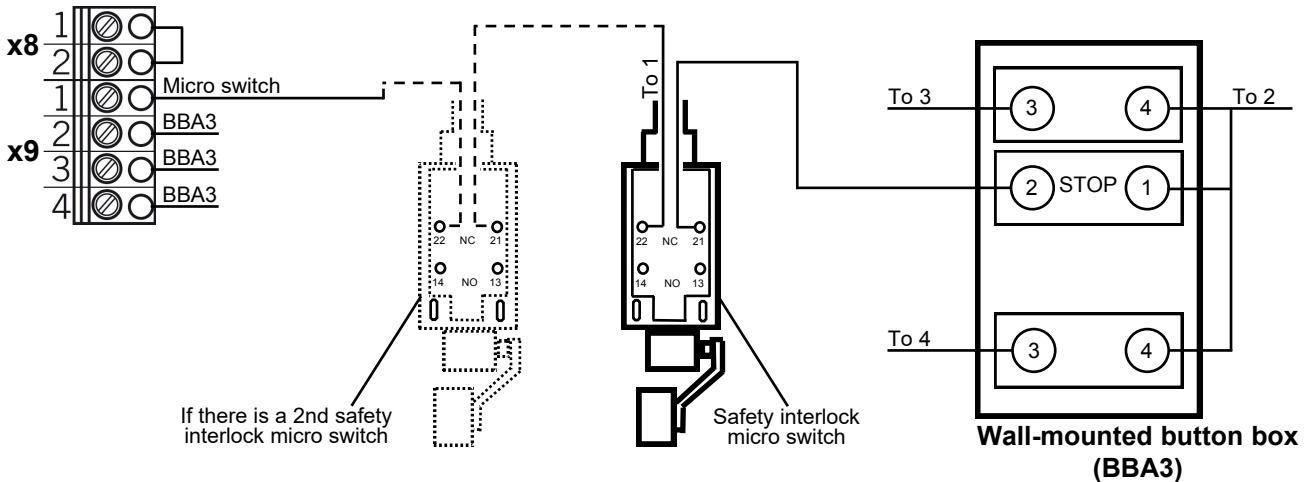

## Key switch box (BCA/BCE) + Box with stop button (BBAS) + Micro switch

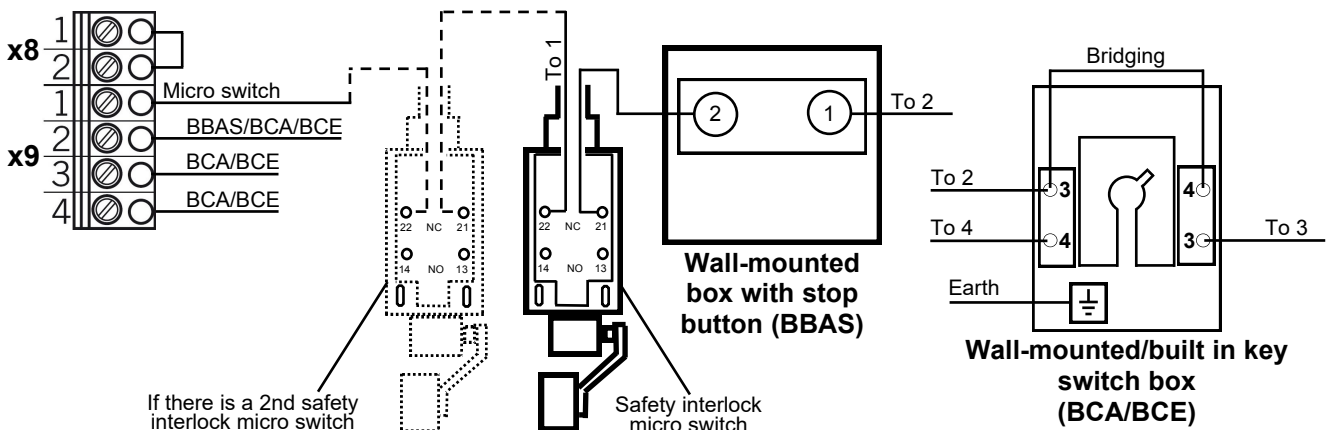



## Display and rectification of faults

### LED 1, green (extension board)

LED display	Fault	Solutions
LED 1 switched off	No operating voltage	Check the power supply at L1, L2 and L3 in X1

### LED 2, red (extension board)

LED display	Fault	Indications	Solutions
1 flashing	STOP error	Shutter stopped after the operator safety devices were activated	Switch off the power, check the safety devices in X8 and X9 and check if the emergency operation device is deactivated
2 flashing	Coding error	Shutter stopped.	Switch off the power and check the connection X21, then press up or down.
3 flashing	End position error	Shutter stopped.	Switch off the power and reprogram the end positions.
4 flashing	Rotating field error	Shutter stopped after the operator rotated in the wrong direction.	Switch the power off then switch the wires U and V on X2.
5 flashing	Forcing error	Shutter stopped. The operator is straining to function.	Switch the power off and check that the shutter is not blocked (presence of rough spots).
6 flashing	Operating time error	Shutter stopped after the operating time of the operator is exceeded.	Switch the power off and wait for the operator to cool down.

## Reinitializing factory settings

- 1 - Hold down the "-" and "P" keys on the bearing plate at the same time.
- 2 - Cut the power supply to the box.
- 3 - While holding down the "-" and "P" keys, reconnect the power supply to the box and continue to hold down the keys until the green LED light comes on.

**Results:** The recorded settings of the end positions are therefore deleted and all the parameters will return to the factory settings

# Finishes

**IMPORTANT!**  
Carefully grease the inside of the guiding rails and the winding plates

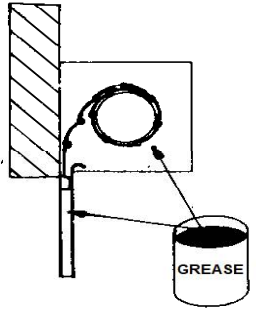

## In case of problems maneuvering the shutter

**! If the anti-fall guard is blocked, contact a trained installer**

If the shutter is crooked when moving up and down

(Gap larger than 4 cm on the end-slat)

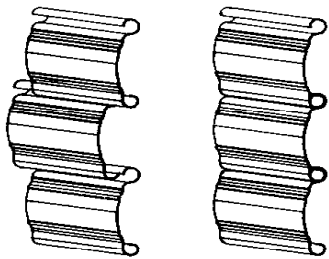

**NO**                      **YES**  
Check that the slats are correctly aligned

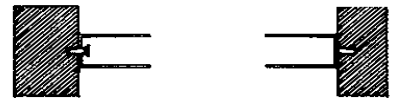

**NO**                      **YES**  
Remove any blockages from inside the guiding rails

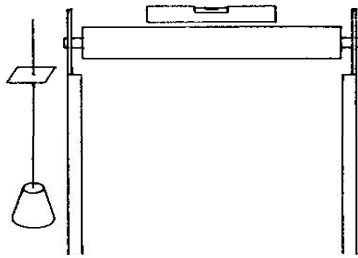

Check that the guiding rails are correctly aligned and that the axle is perfectly horizontal.

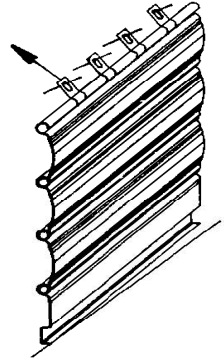

Roll up the shutter from the lowest side using the clip apertures provided for this purpose

## In case of incorrect functioning of the operator

**Most importantly, never force the operator to work by directly activating the power contactors**

**Triple-phase operator:** check the 400V or 230V voltage between each phase.  
Check that the emergency operation control is not activated.

# Assembling the hoist on the E400 operator (Option)



- To fix the hoist in place, it is essential to use the 4 screws provided with the hoist (Length = 70 mm) instead of the 4 original screws (Length = 95 mm).  
Do not use an electric screwdriver to tighten the screws as this might damage the operator.

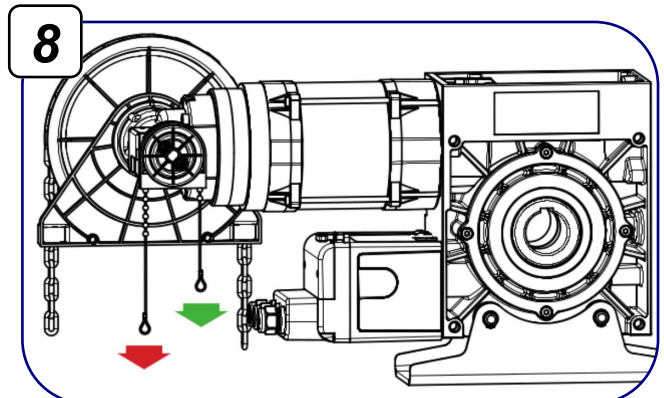
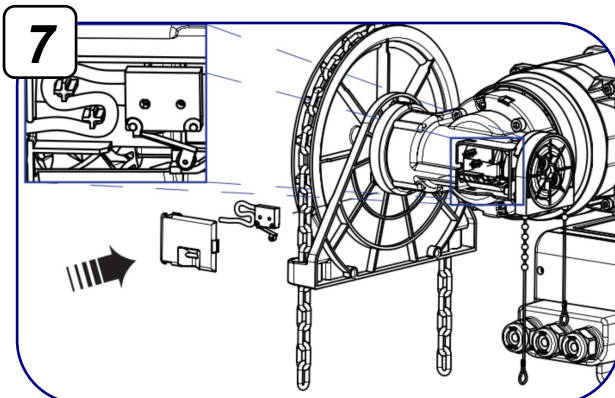
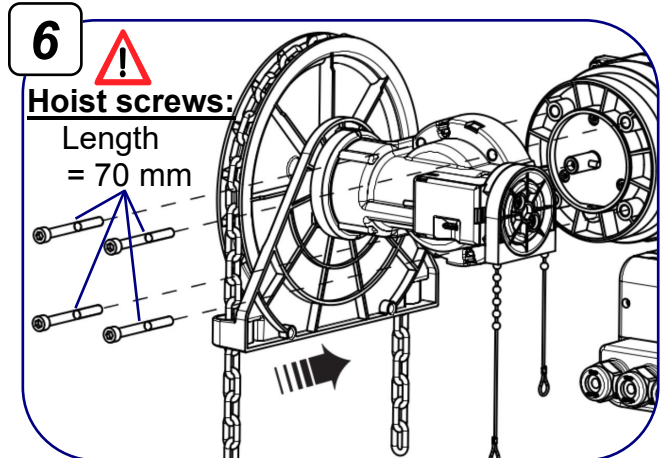
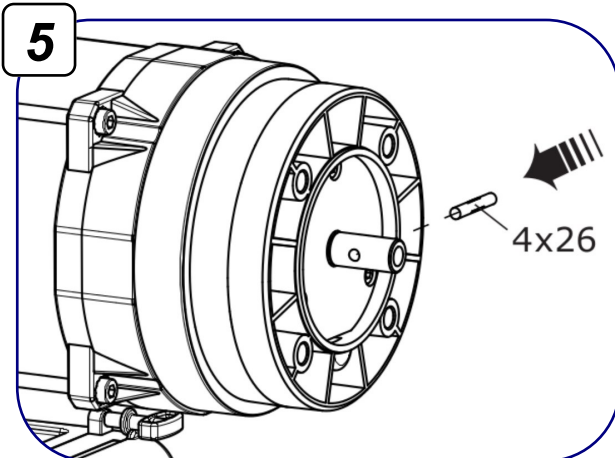
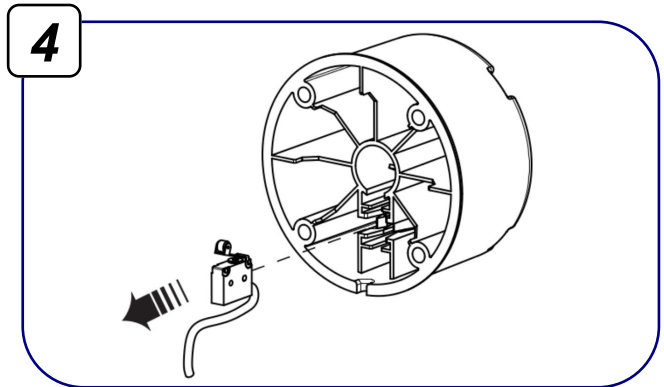
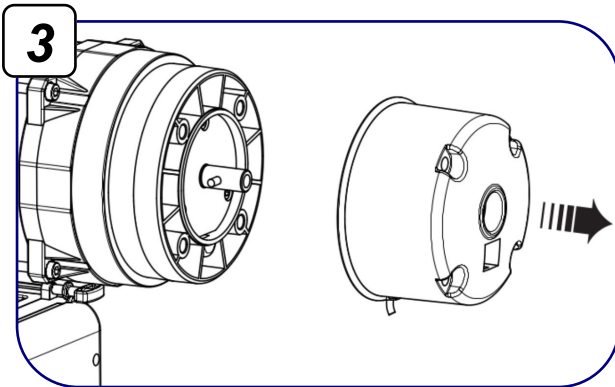
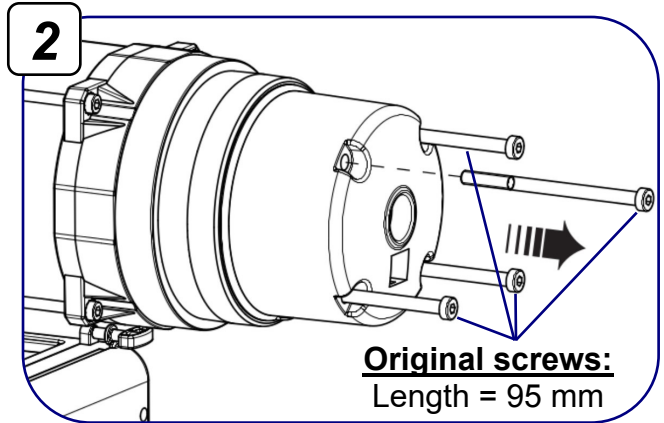
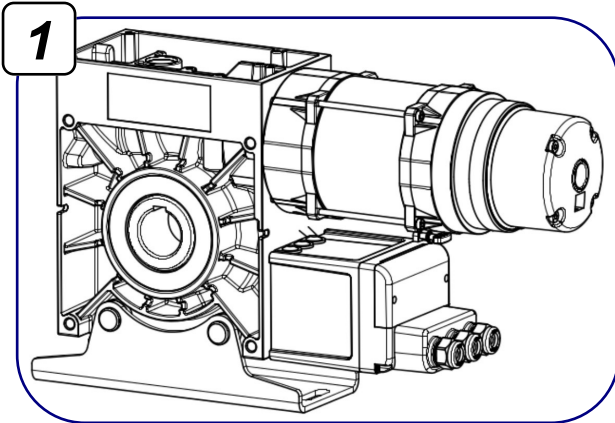

# Assembling the hoist on the E750 operator (Option)

-  - To fix the hoist in place, it is essential to use the 4 screws provided with the hoist (Length = 50 mm) instead of the 4 original screws (Length = 65 mm).
- Do not use an electric screwdriver to tighten the screws as this might damage the operator.

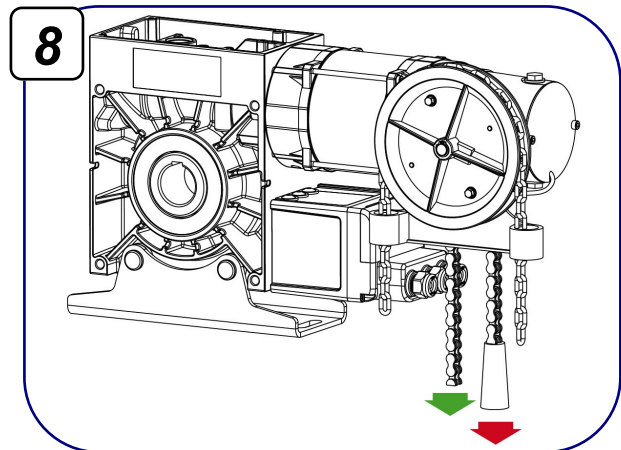
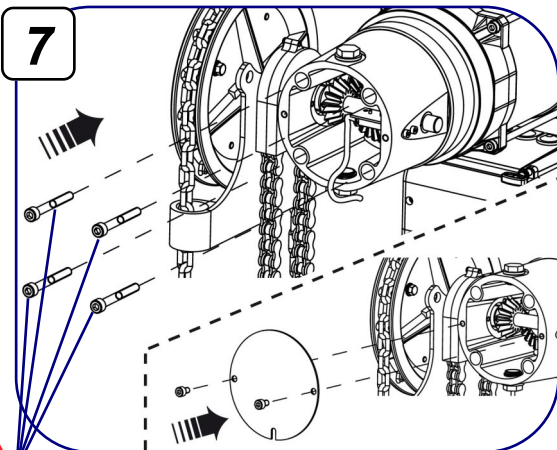
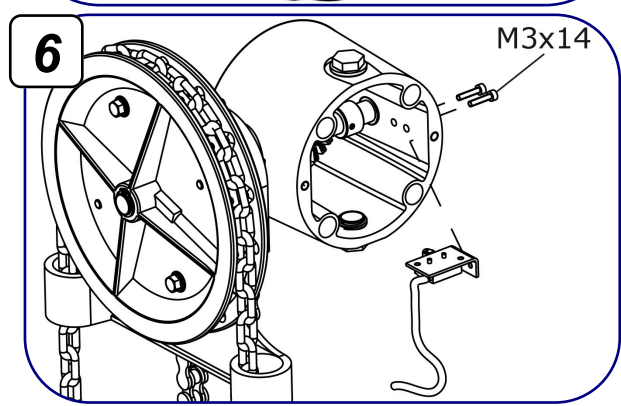
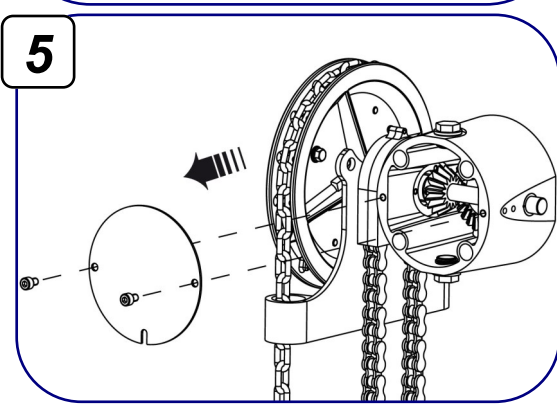
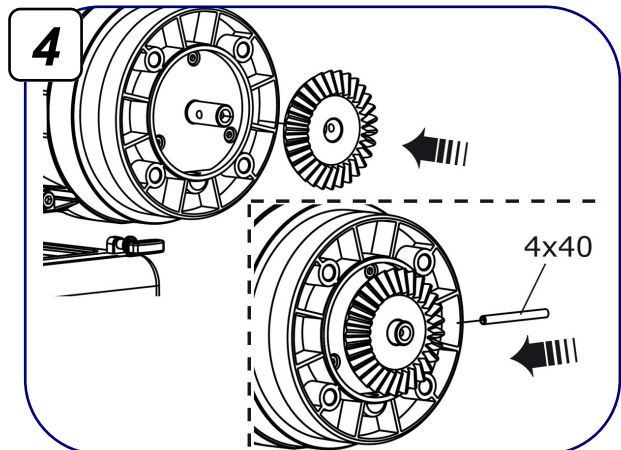
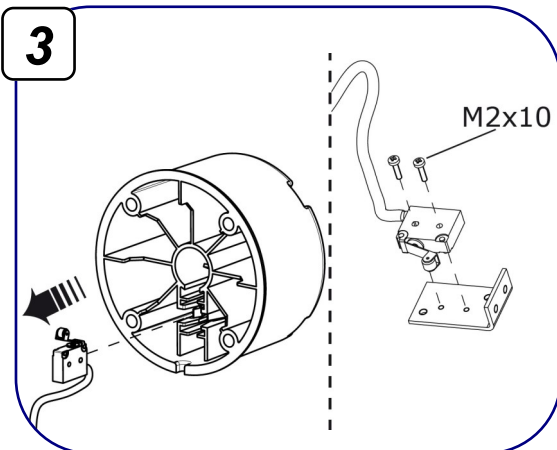
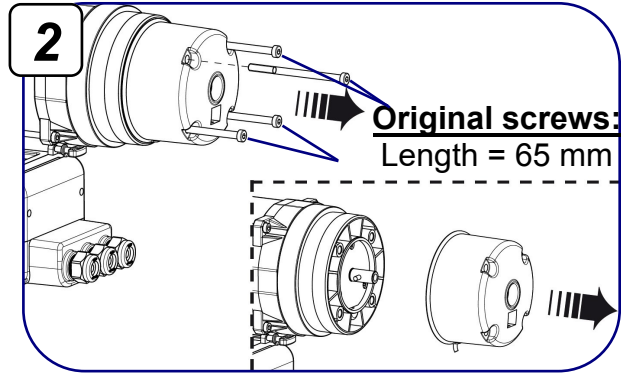
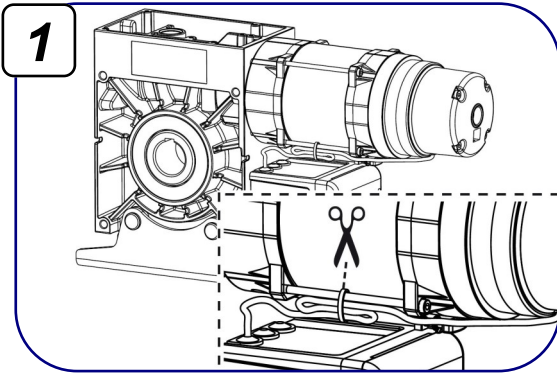

 **Hoist screws:** Length = 50 mm

to be displayed next to the closure

## Emergency operation using the crank

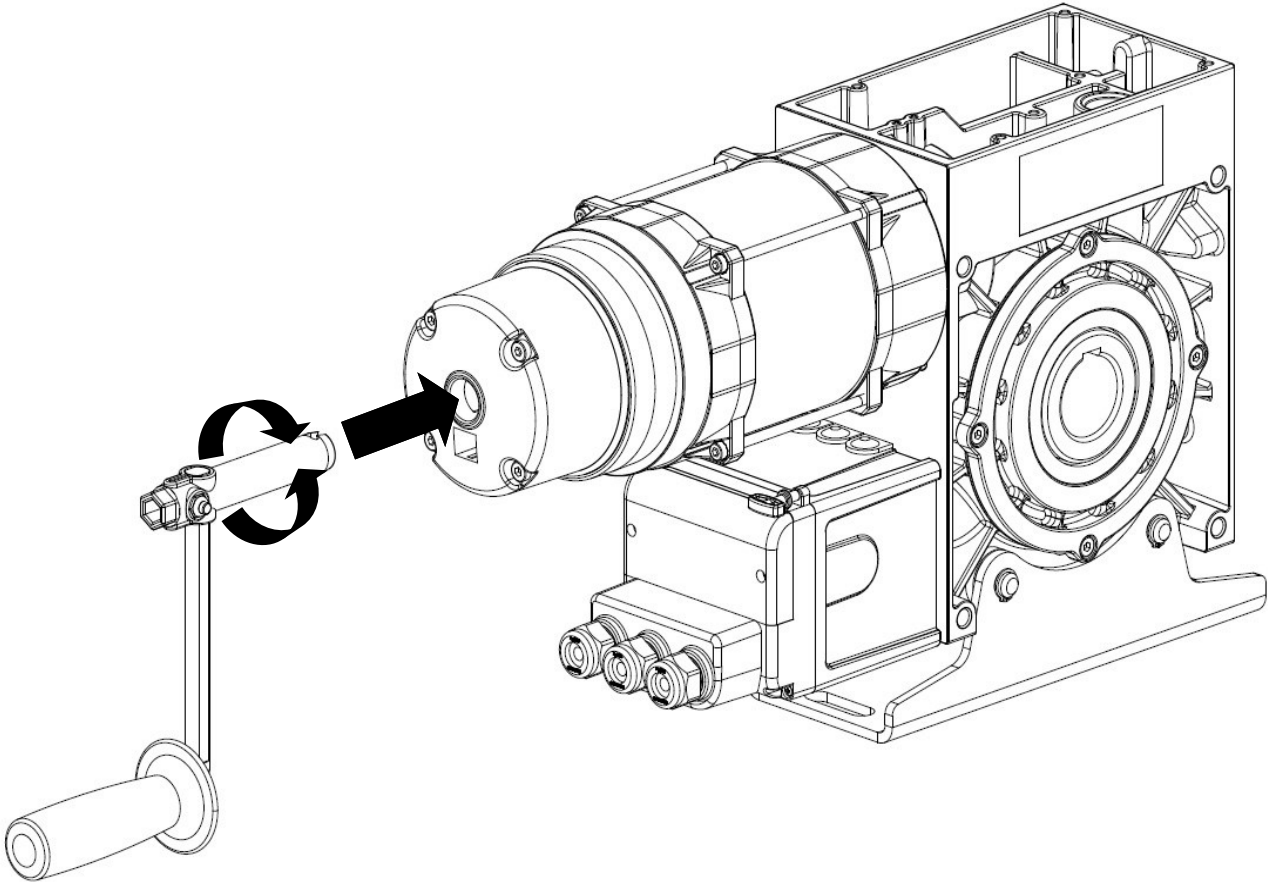

- 1- Insert the crank into the operator as far as it will go (the operator power supply is cut off and the door cannot operate electrically).
- 2 - Turn the crank in one direction to open the door and in the other direction to close it.
- 3 - Once repairs are completed, remove the crank (the operator power is reactivated and the door can operate electronically).



**Never pull the operator brake when repairing the operator or when it is in operation.**

## Technical help contact details

(Installer's stamp)

to be displayed next to the closure

**Emergency operation using the hoist (Option)**

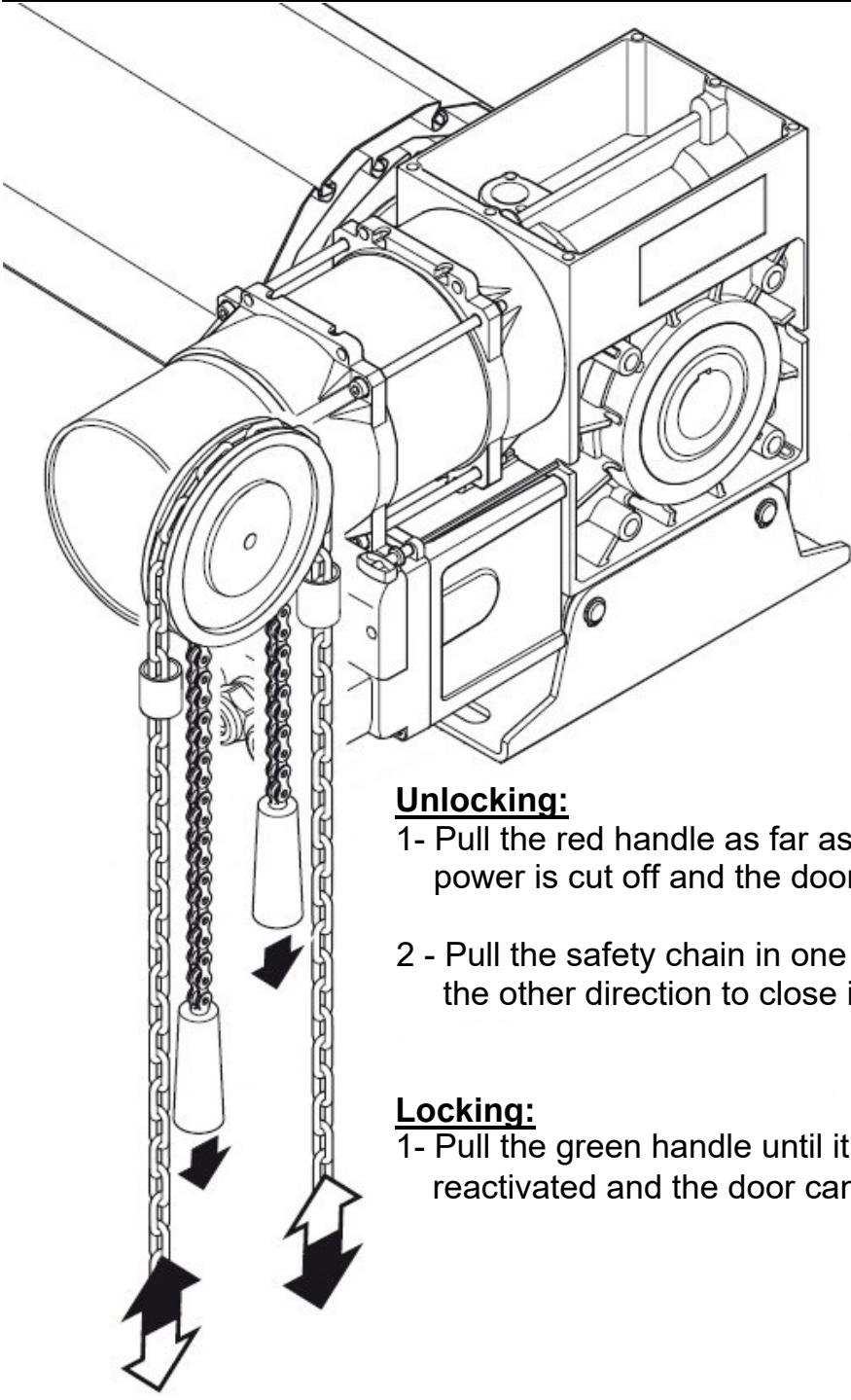

**Unlocking:**

- 1- Pull the red handle as far as it will go. (the operator power is cut off and the door cannot operate electronically).
- 2 - Pull the safety chain in one direction to open the door and in the other direction to close it.

**Locking:**

- 1- Pull the green handle until it stops. (the operator power is reactivated and the door can operate electronically).

 **Never pull the operator brake when repairing the operator or when it is in operation.**