

Notice N° 7039

02/23

INSTALLATION

Portes de garage résidentielles



Déplacement Latéral Cadre
avec Portillon côté opposé refoulement
Manuelle - Refoulement 90°



(Document réservé aux installateurs)

Sommaire

Instructions d'installation	3
Avant la pose	4
Matériel nécessaire	4
Contenu des kits selon configuration/options de la porte.....	5
Accessoires en standard	5
Accessoires portillon.....	6
Accessoires en option.....	6
Vérification des surfaces	7
Cadre support.....	7
Montage et découpe des joints.....	7
Montage des patins	8
Pièces nécessaires	9
Assemblage du cadre au sol	10
Installation du cadre	10
Cadre de refoulement (Refoulement à gauche représenté).....	12
Rail côté baie (Refoulement à gauche représenté).....	14
Assemblage du "rail de guidage haut" sur le sol	14
Assemblage et montage du support de cintre	15
Assemblage du cintre	15
Montage du rail de guidage.....	16
Assemblage du cintre (partie 2)	17
Fixer les 2 supports.....	17
Butée tablier (Refoulement à gauche représenté)	18
Montage de la butée	18
Tablier (Refoulement à gauche représenté)	19
Vue d'ensemble et montage de la poignée encastrée	19
Préparation du panneau intermédiaire portillon	20
Préparation des panneaux intermédiaires	21
Assemblage des panneaux intermédiaire portillon & intermédiaire "poignée"	22
Installation des panneaux intermédiaire portillon & intermédiaire "poignée"	23
Préparation du panneau côté refoulement.....	24
Installation des panneaux intermédiaires par 2 ou avec panneau côté refoulement	26
Contrôler la position du tablier	27
Contrôler le parallélisme	27
Préparation du panneau portillon	28
Installation du panneau portillon	29
Assemblage du "rail de guidage haut" sur le sol	30
Montage du rail de guidage.....	31
Les différents équipements côté refoulement.....	32
3 cas possibles (Refoulement à gauche représenté).....	32
Bras multiposition pour écoinçon : $300 \leq \text{ECR} \leq 585$ mm	33
Montage du bras	33
Rallonge pour écoinçon : $585 < \text{ECR} \leq 650$ mm.....	34
Préparation de la rallonge	34
Montage de la rallonge.....	34
Pas d'équipement pour écoinçon : $\text{ECR} > 650$ mm	35
Finitions pour tous les types d'écoinçons	35
Montage de la butée de fin de course.....	35
Montage des butées fixes.....	36
Réglage des patins	39
Fixer les supports de rail intermédiaires	39
Montage du guidage.....	40
Système de placage du tablier (panneau côté refoulement).....	40
Accessoires	42
Montage du verrou bas	42
Montage de l'arrêt portillon.....	43
Option.....	45
Montage du verrou haut	45

Instructions d'installation



Pour que le montage, l'utilisation et l'entretien de ce produit soient réalisés en toute sécurité, il est nécessaire de suivre les instructions données ici.

Pour la sécurité de tous, respectez les mesures de précaution ci-dessous.

- Avant de procéder au montage, lisez attentivement cette notice.
- Cette fermeture doit être installée par un installateur professionnel.
- Toutes les pièces livrées sont calculées spécifiquement pour ce produit. Ajouter et/ou utiliser d'autres éléments peut être préjudiciable à la sécurité et à la garantie du produit.
- Toute modification ou amélioration de cette fermeture doit être conforme à la norme EN 13241 + A2. Dans ce cas, un dossier " Modification/Transformation " doit être établi par l'installateur suivant la norme EN 12635 annexe C.
- Travailler en respectant les consignes de sécurité. Utiliser les outils nécessaires à la mise en œuvre des produits. Veiller à travailler sur un sol stable.
- Veiller à avoir un espace de montage suffisamment lumineux, dégagé, propre et balisé.
- Veiller à ce qu'aucune autre personne que les installateurs ne soit présente sur le chantier. En effet, les personnes non autorisées comme les enfants, pouvant être présents sur le chantier, risquent de se blesser durant le montage.
- Tous les composants de cette fermeture doivent être installés conformément aux instructions d'installations stipulées dans cette notice.
- Toutes les exigences des normes EN 13241 + A2 doivent être satisfaites et vérifiées, si nécessaire.

Couple maxi de serrage :

Vis d'assemblage = 10 Nm

Vis de montage tablier = 12 Nm

Charge de service mini par patte équerre = 40 daN

Avant la pose

Matériel nécessaire

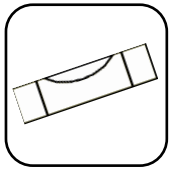

Niveau à bulle

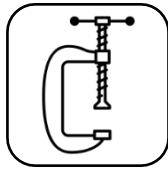

Serre-joints

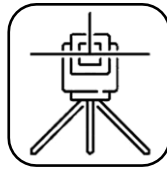

Niveau laser

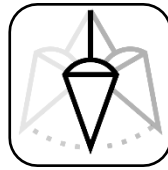

Fil à plomb

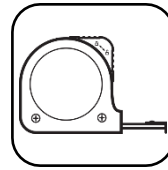

Mètre (8 m)

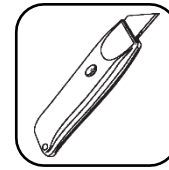

Cutter

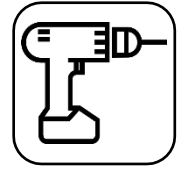

Visseuse

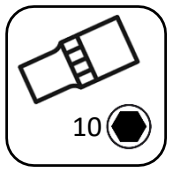

Douille



Embout
cruciforme



Embout Torx



Embout carré
(fourni)

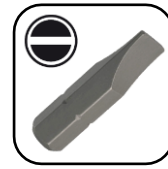

Embout plat



Embout
hexagonal



Clé plate

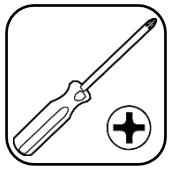

Tournevis
cruciforme



Tournevis
plat



Crayon



Maillet



Marteau

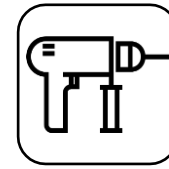

Perforateur

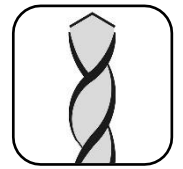

Forets acier
long. maxi 30 mm



Pince étau



Règle
de maçon



Tréteaux

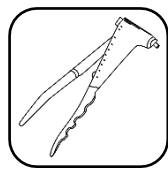

Pince
à riveter

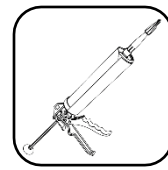

Joint silicone
(conseillé)

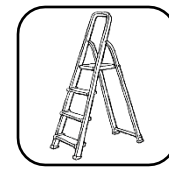

Echelle



Lubrifiant

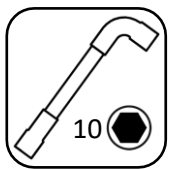

Clé à pipe

Chevilles et vis adaptées

Cales en plastique (fournies)

Contenu des kits selon configuration/options de la porte

Accessoires en standard

KIS-033 ou KIS-039
(charnières centrales)



KIS-600 (courbe)



KIS-605 ou KIS-606
(supports de rail côté refolement)

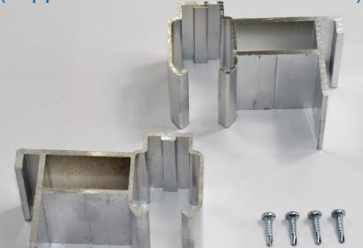

KIS-607 ou KIS-608
(supports de rail côté baie)

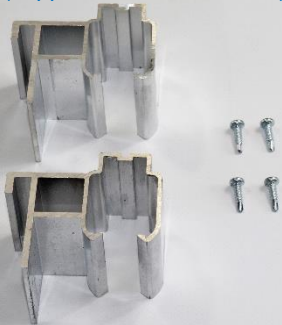

KIS-612 avec ASC-167 (bras multiposition)*



KIS-620 (kit de dépannage)



KIS-624 (support chariot)*

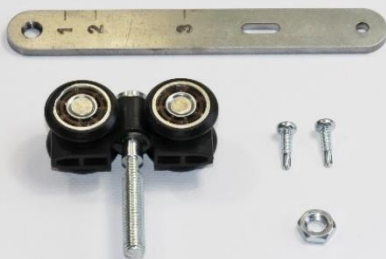

KIS-621 ou KIS-622 (rallonge)*



KIS-627 ou KIS-628*
(système de placage)



KIS-629 (système de placage)*



KIS-660 (accessoires cadre & guidage)

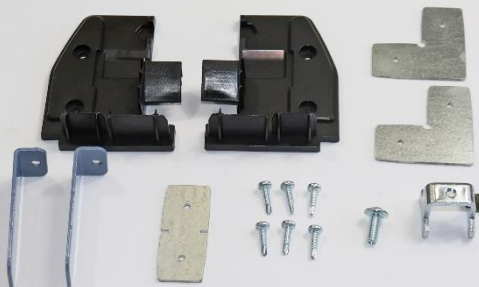

KIS-663 ou KIS-664
(patins de guidage intermédiaires)



KIS-665 (patin d'extrémité/verrou)



JNT-064 (joints brosse)



ASC-588 (tube renfort de courbe)



JNT-066 (joint caoutchouc)



*En fonction des écoinçons



Accessoires portillon



Accessoires en option



Vérification des surfaces



Vérifier les planétés des zones écoinçons et retombée de linteau

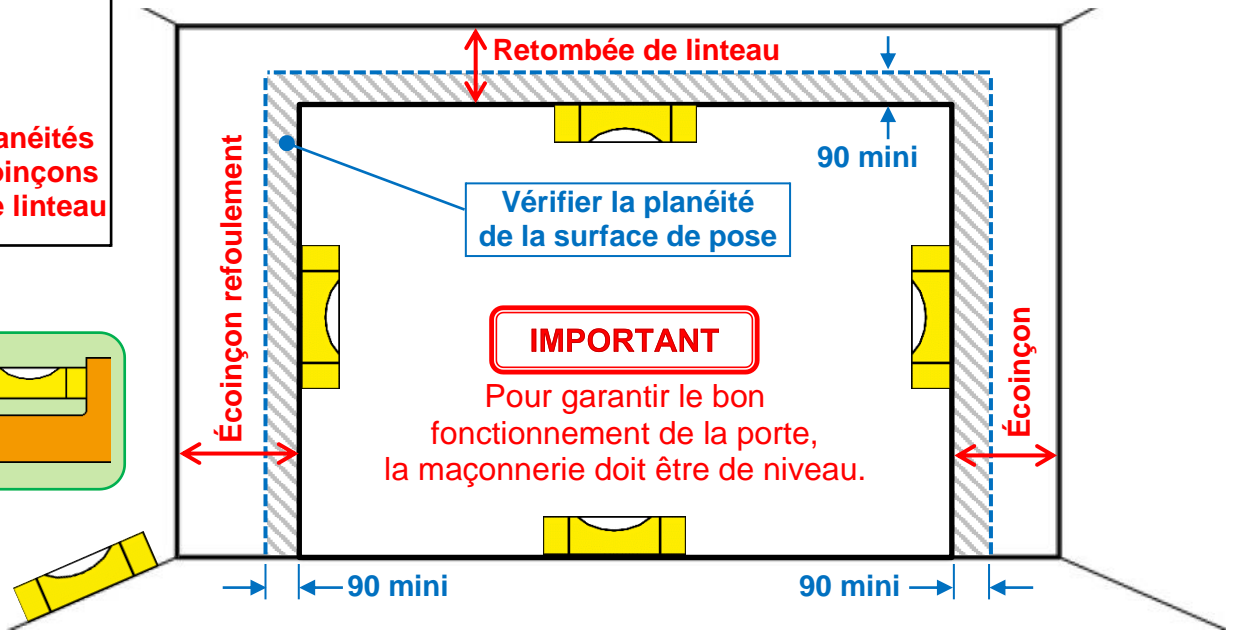
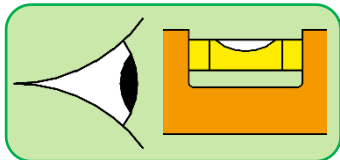

IMPORTANT : Refoulement à gauche décrit

Cadre support

Montage et découpe des joints

- Au linteau : Joint caoutchouc 35 mm

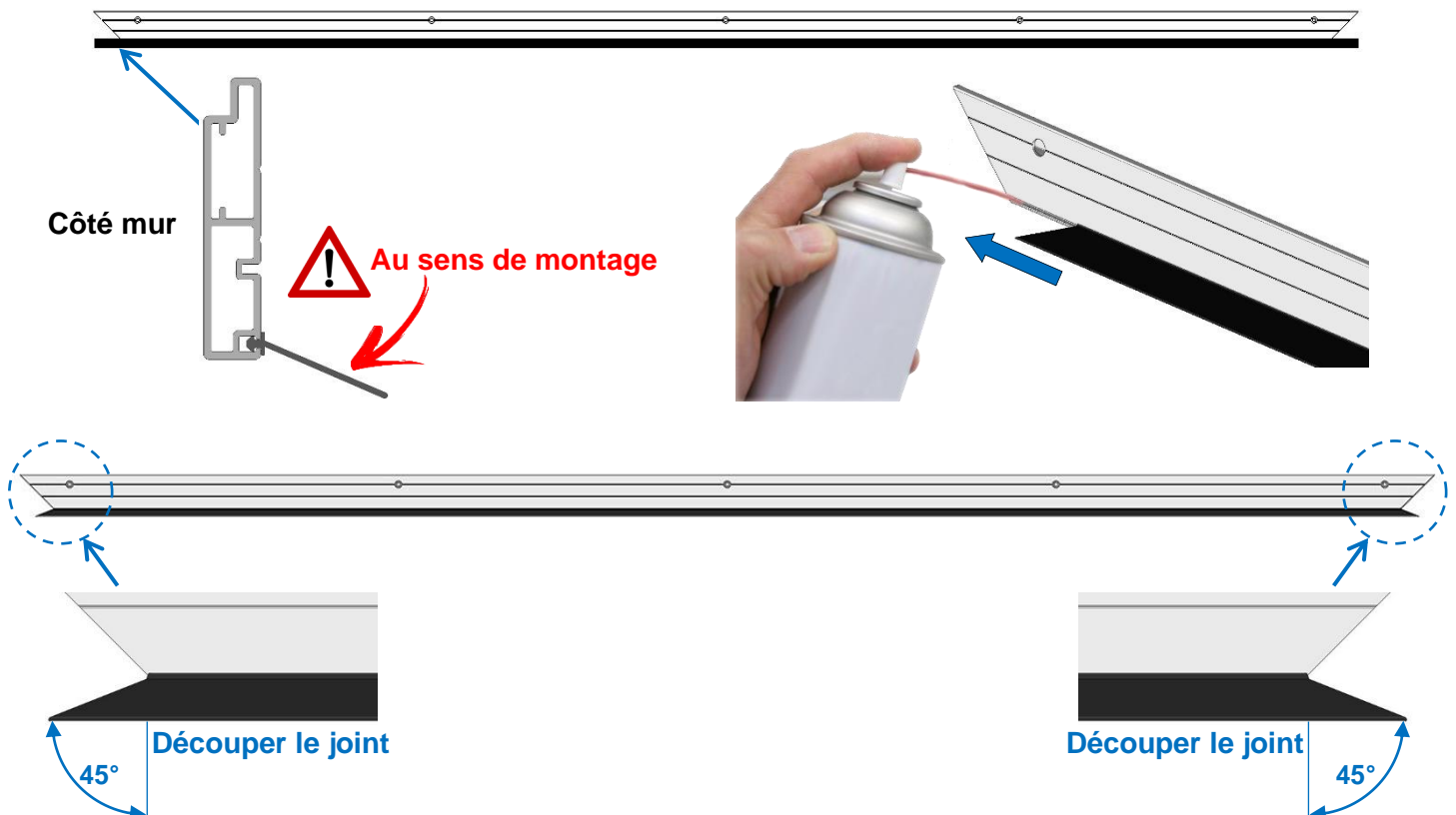

• **Côté refoulement :**

• **Côté opposé refoulement :**

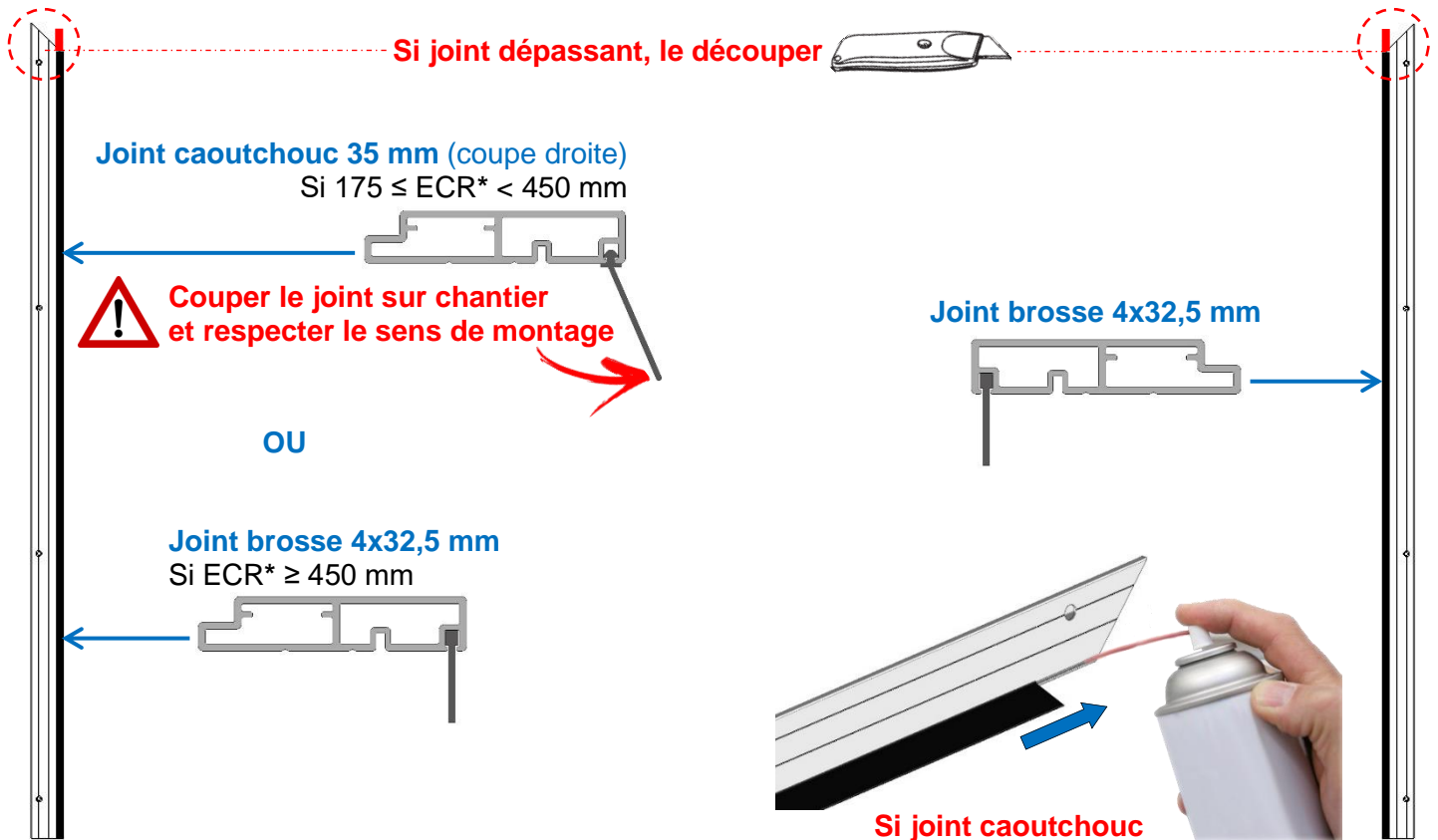

*ECR = Écoinçon Côté Refoulement

Montage des patins

1- Assembler les patins intermédiaires

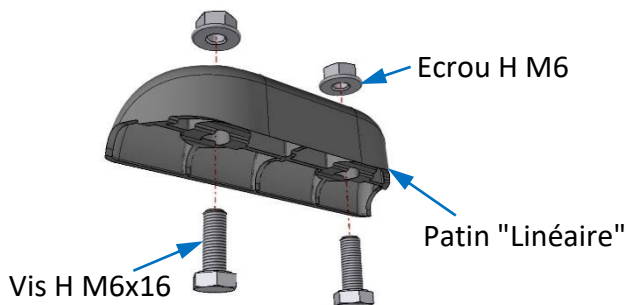

2- Assembler le(s) patin(s) Portillon/Verrou

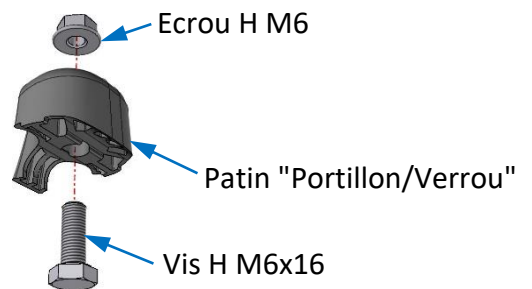

3- Glisser les patins sur le seuil, sans serrer les écrous

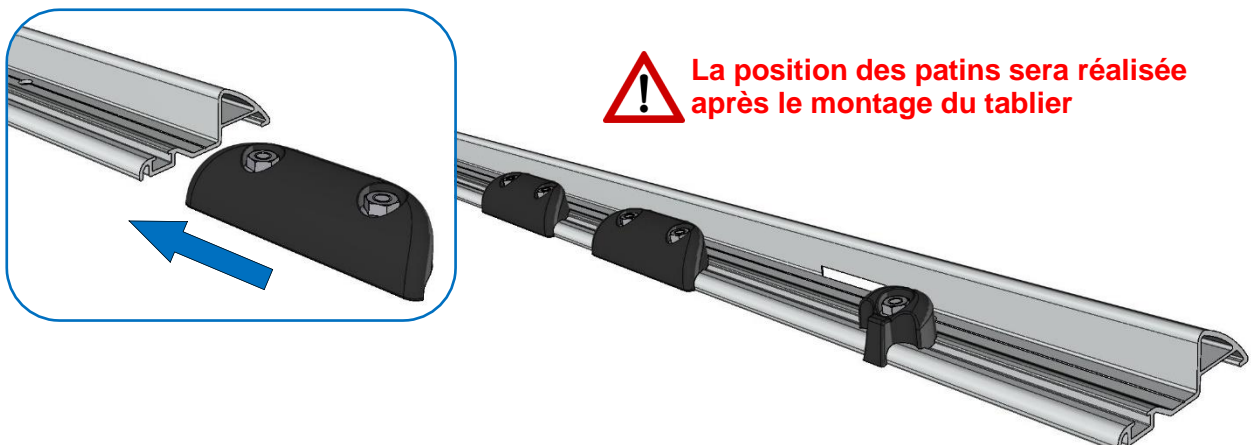

LOGIQUE DE MONTAGE DES PATINS

← Refoulement à gauche

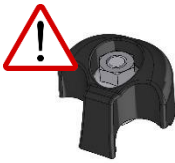

SI OPTION VERROU

Positionner le patin supplémentaire "portillon/verrou" dans la zone du panneau choisi.

Refoulement à droite →

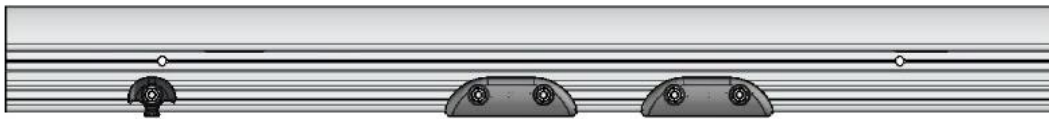

Nota : Pour plus d'informations sur la combinaison des patins, voir chapitre : "Finitions → Réglage des patins".

Pièces nécessaires

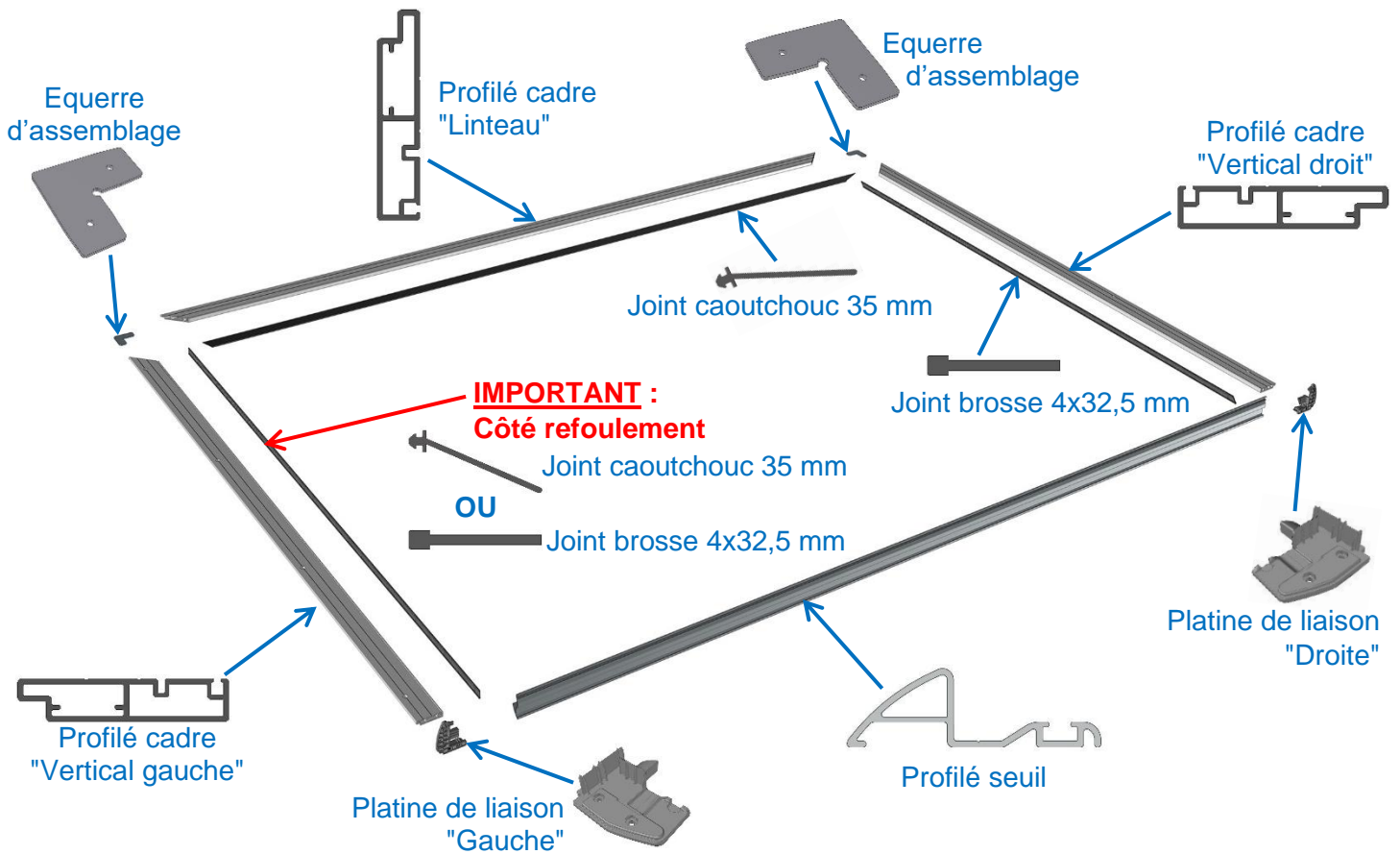

Assemblage du cadre au sol

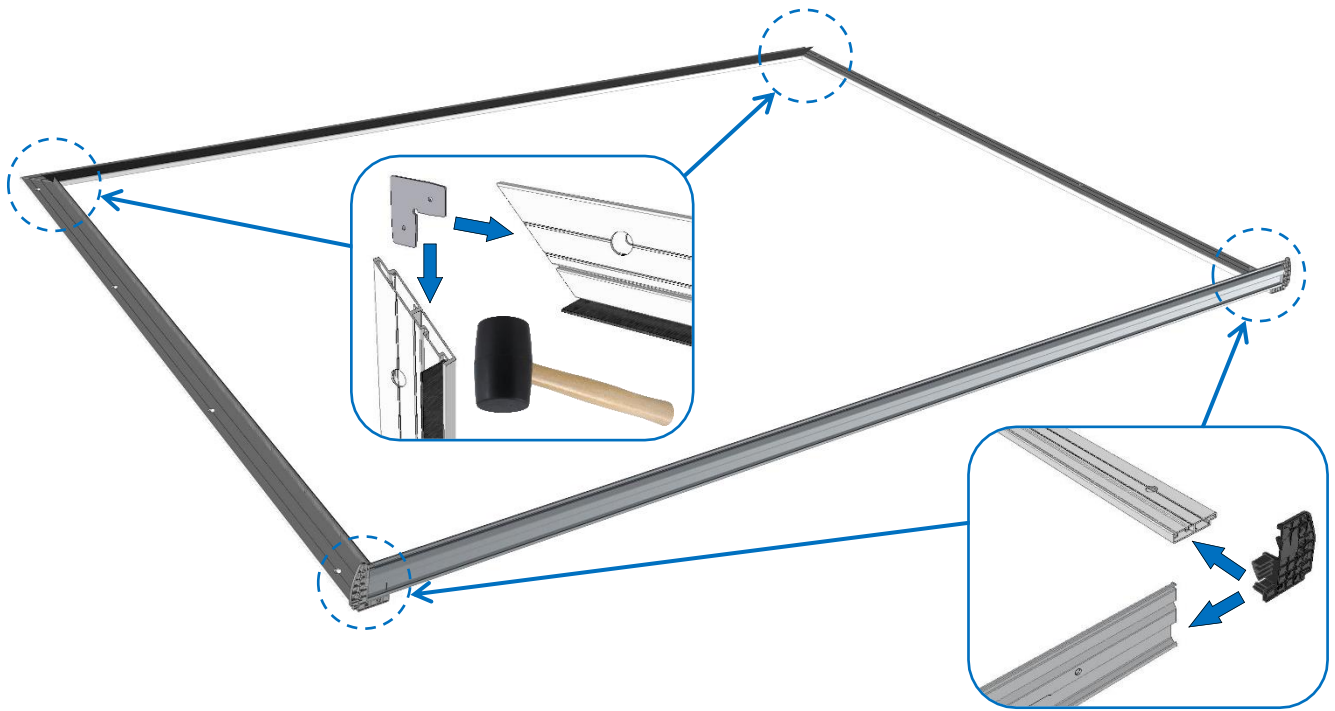

Installation du cadre

- Relever le cadre dans la baie :

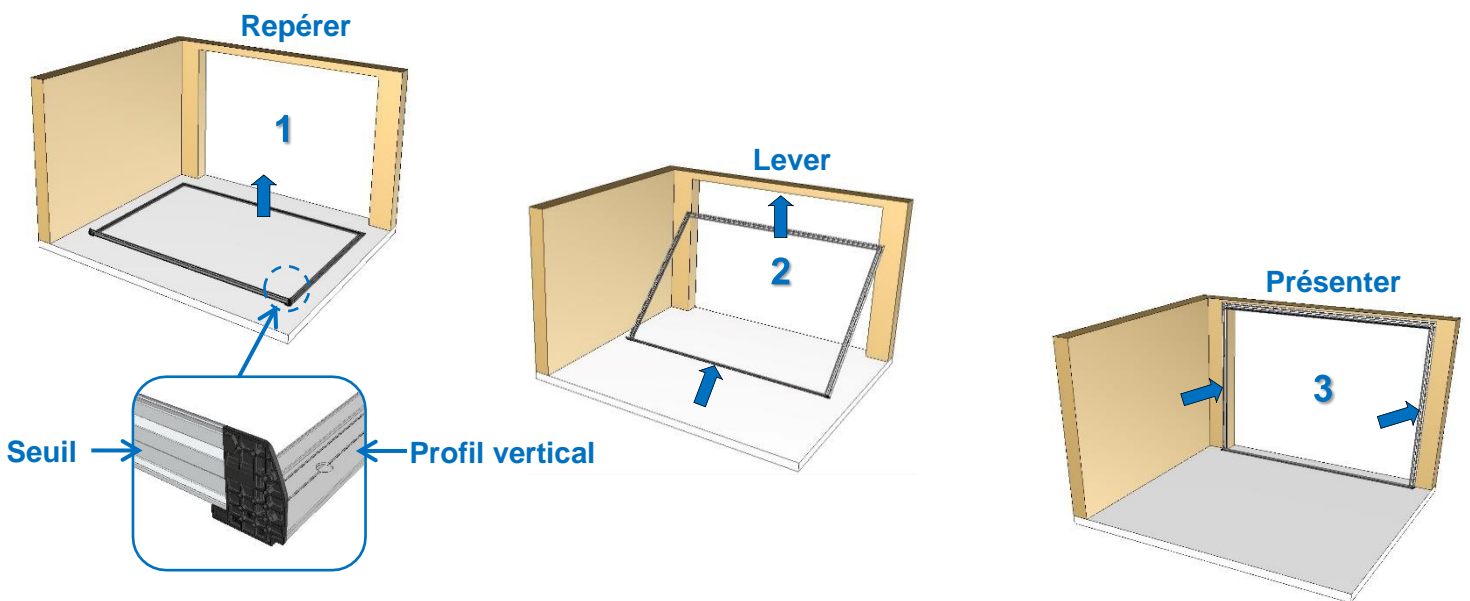

Conseil : Rajouter un **joint silicone** pour assurer l'étanchéité (silicone non fourni).

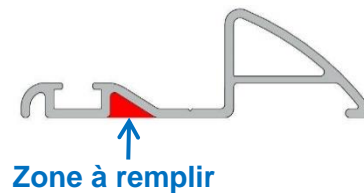

• **Positionner le cadre de niveau, d'aplomb et d'équerre :**

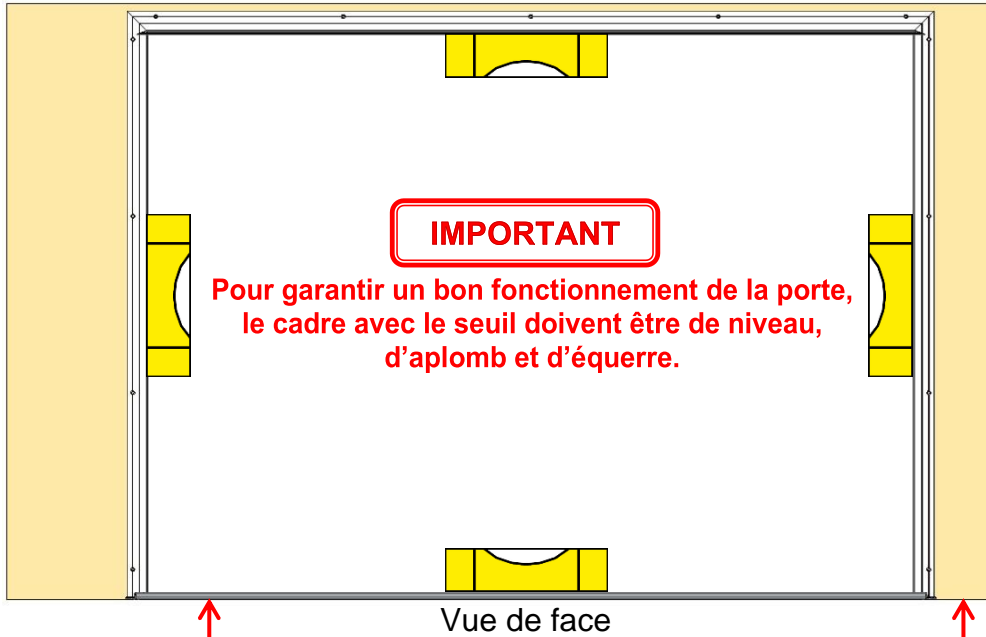
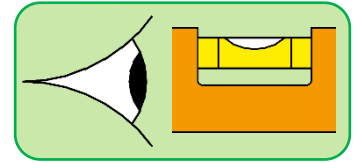

! D'aplomb et bien plan

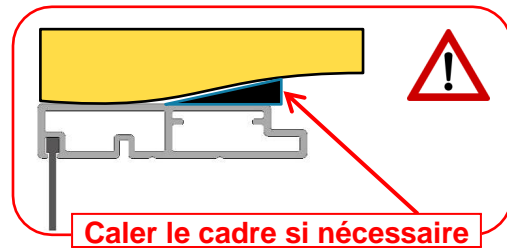
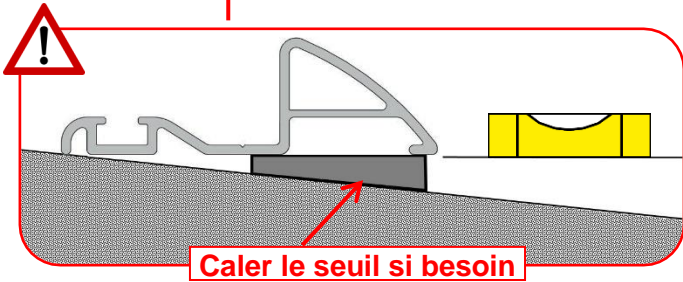
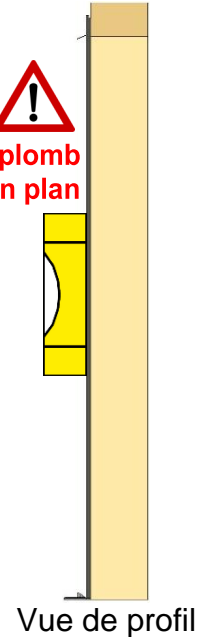

• **Fixer le cadre, le seuil et les platines de liaison :**

Utilisez des fixations (non fournies) adaptées au support

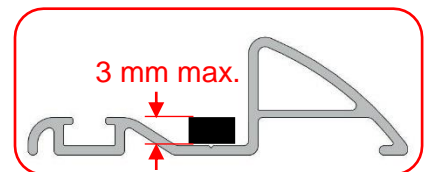
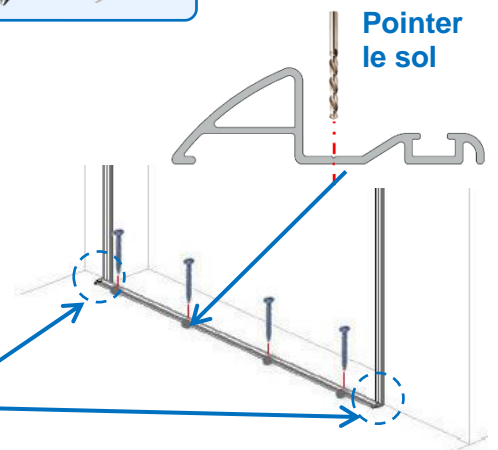
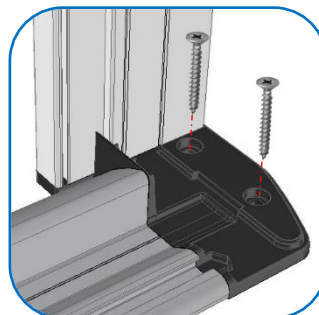
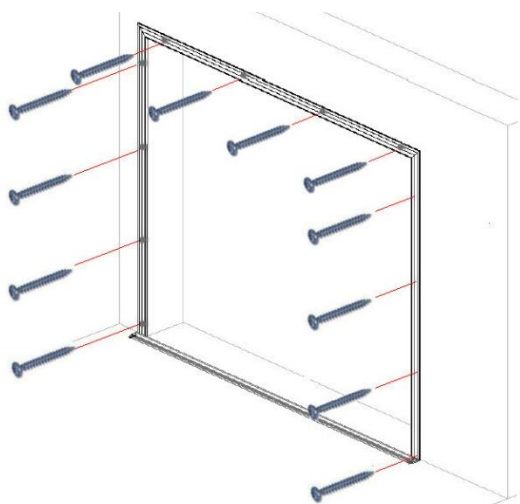
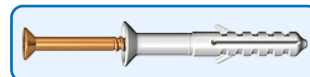

! Les chevilles à frapper ne doivent pas dépasser une hauteur de 3 mm

Cadre de refoulement (Refoulement à gauche représenté)

- Positionner de niveau le 1^{er} profilé de refoulement et le fixer (visserie non fournie)

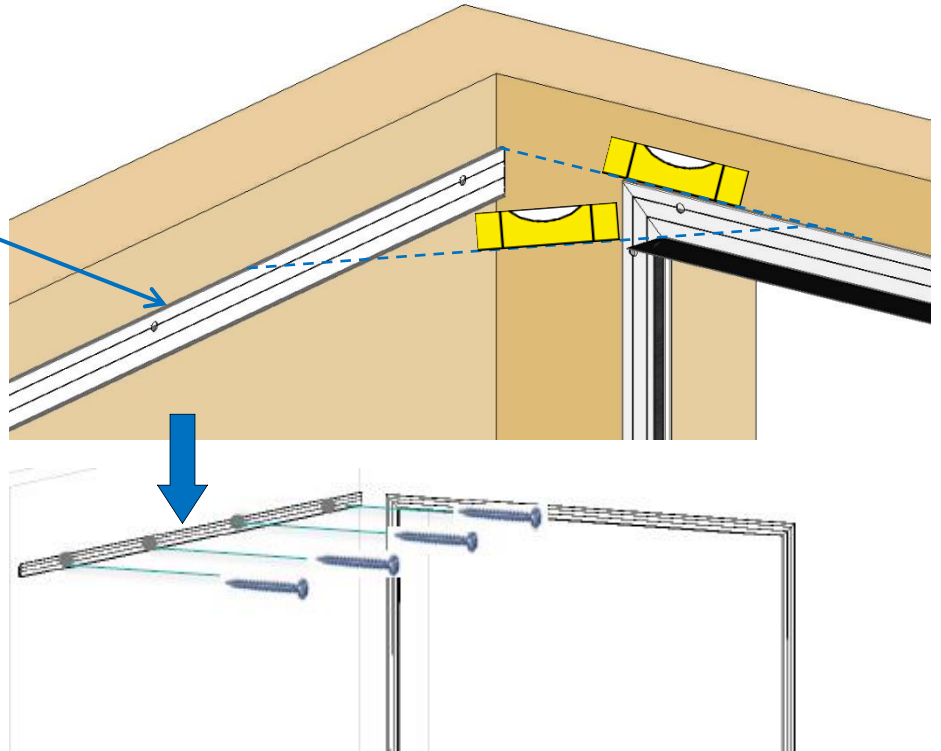
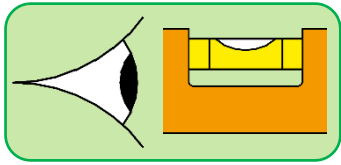

- Si profilé de refoulement en 2 parties, effectuer le montage ci-dessous :

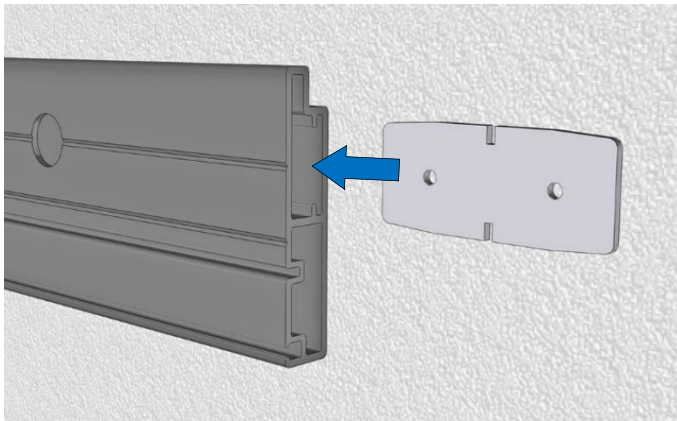

Insérer l'éclisse dans le 2^{ème} profilé

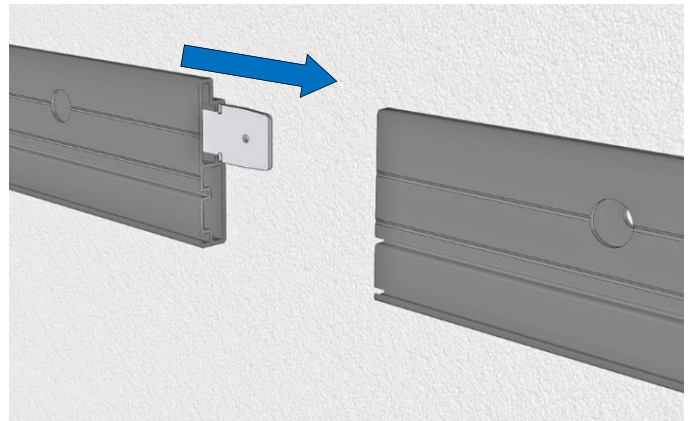

L'assembler avec le 1^{er} profilé

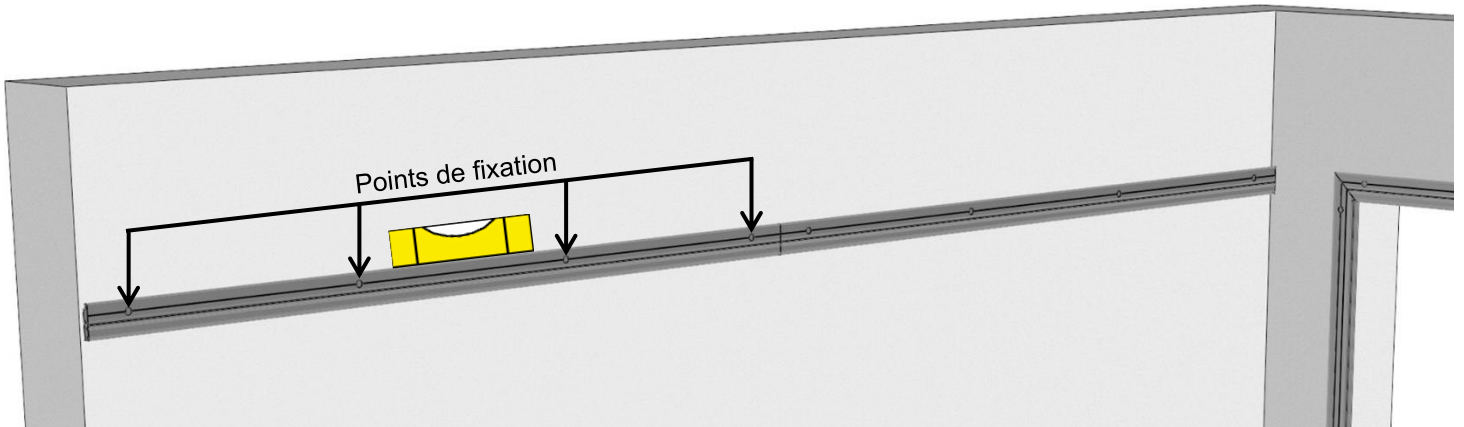

Positionner le 2^{ème} profilé de niveau et le fixer (visserie non fournie)

- **Si Écoinçon Côté Refoulement (ECR) > 400 mm :**
Positionner de niveau le 1^{er} profilé écoinçon et le fixer (visserie non fournie)

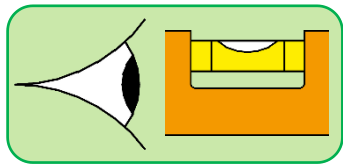

Profilé cadre "écoinçon"

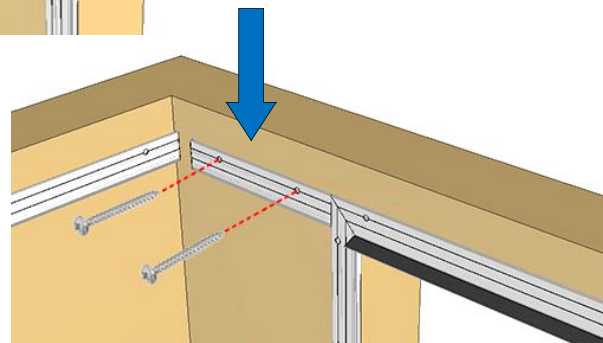
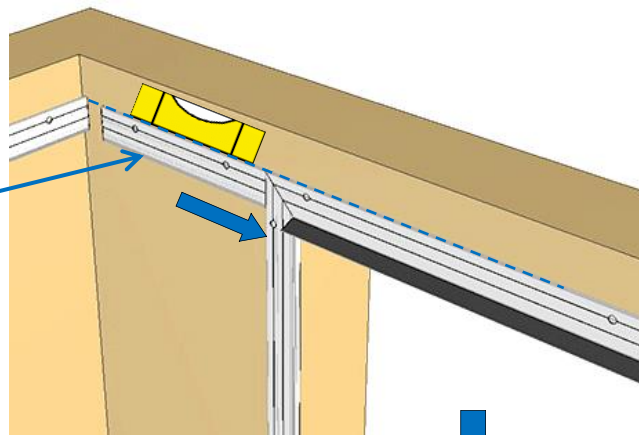

- **Si profilé écoinçon en 2 parties, effectuer le montage ci-dessous :**

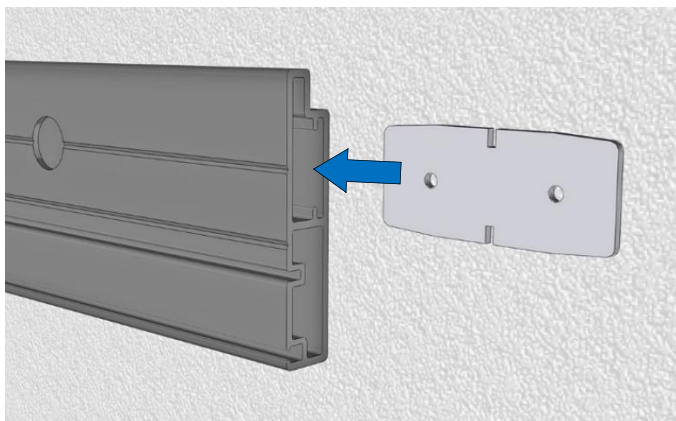

Insérer l'éclisse dans le 2^{ème} profilé

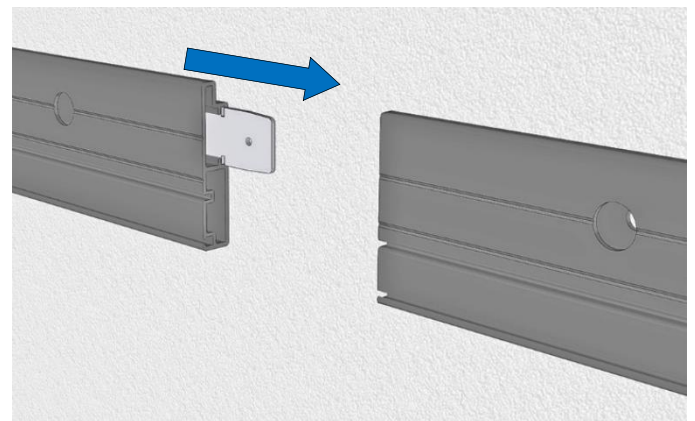

L'assembler avec le 1^{er} profilé

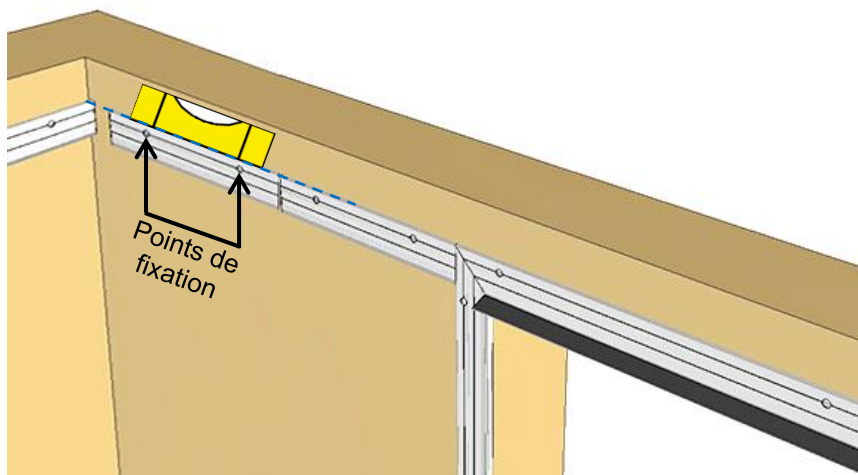

Positionner le 2^{ème} profilé de niveau et le fixer (visserie non fournie)

Rail côté baie (Refoulement à gauche représenté)

Assemblage du "rail de guidage haut" sur le sol

• Rail en 1 partie :

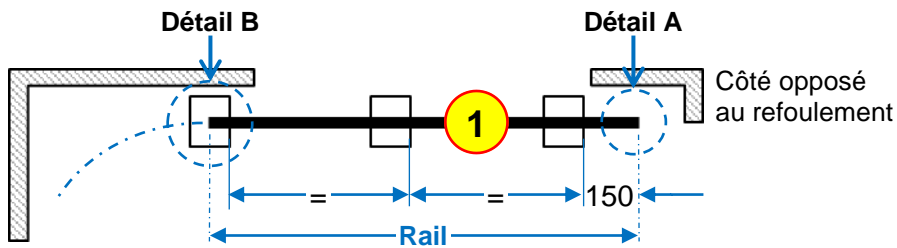

• Rail en 2 parties :

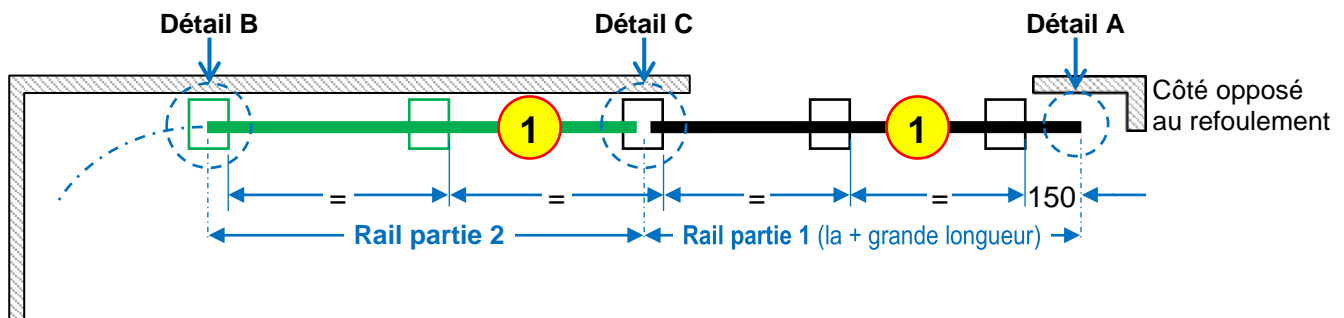

Profilé

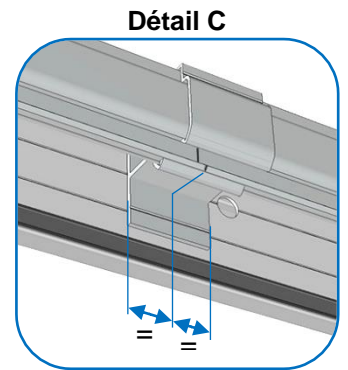
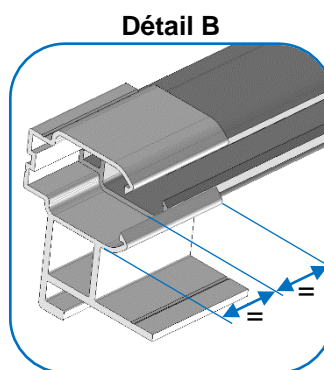
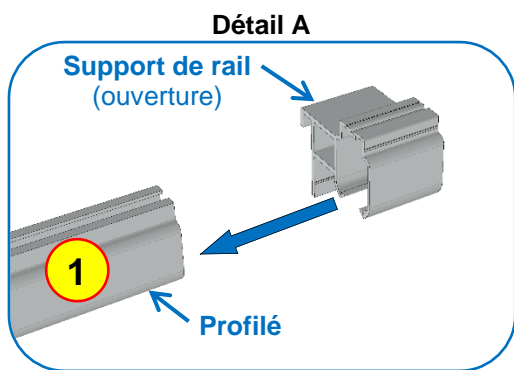
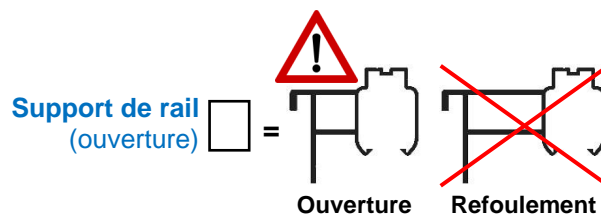
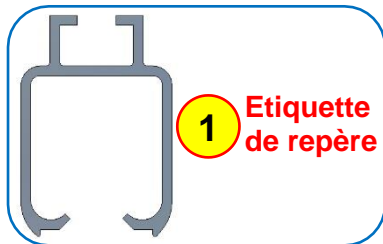

Assemblage et montage du support de cintre

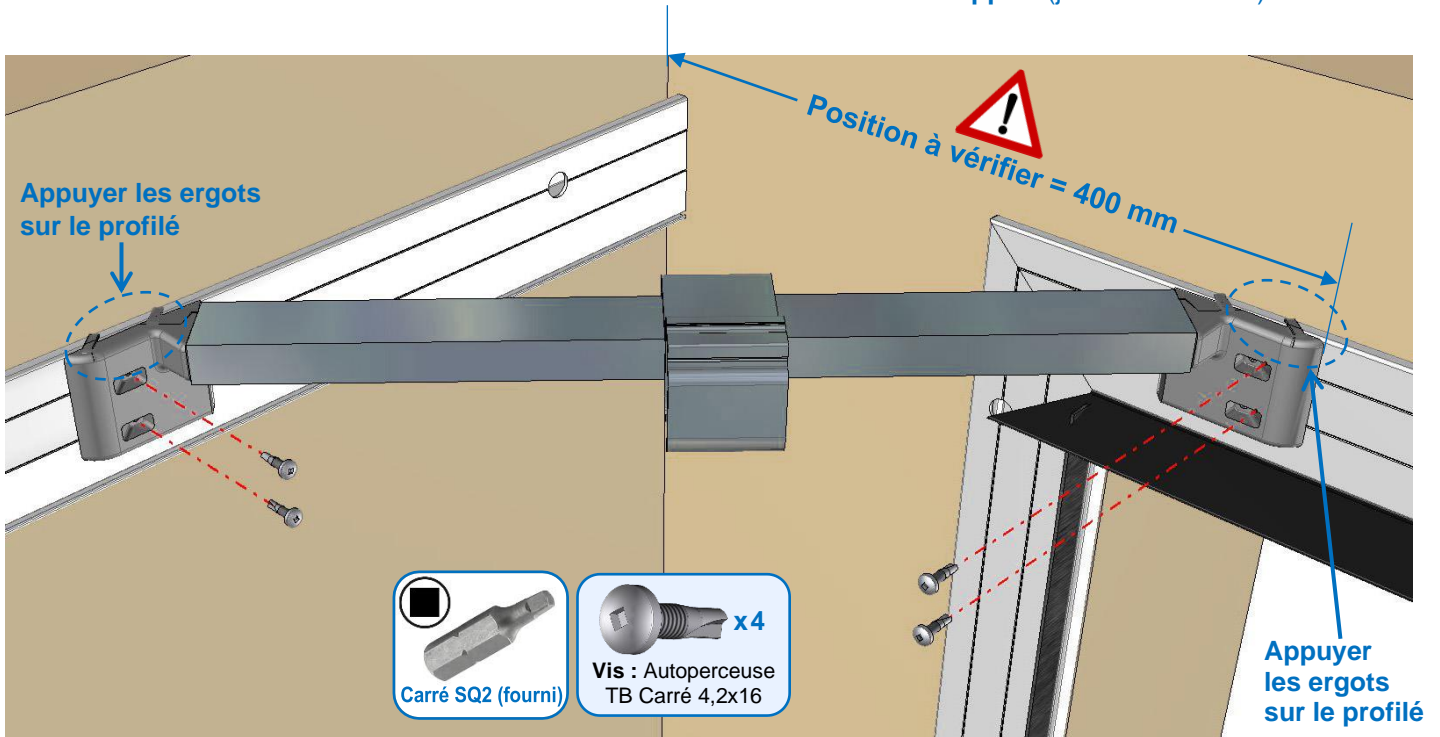
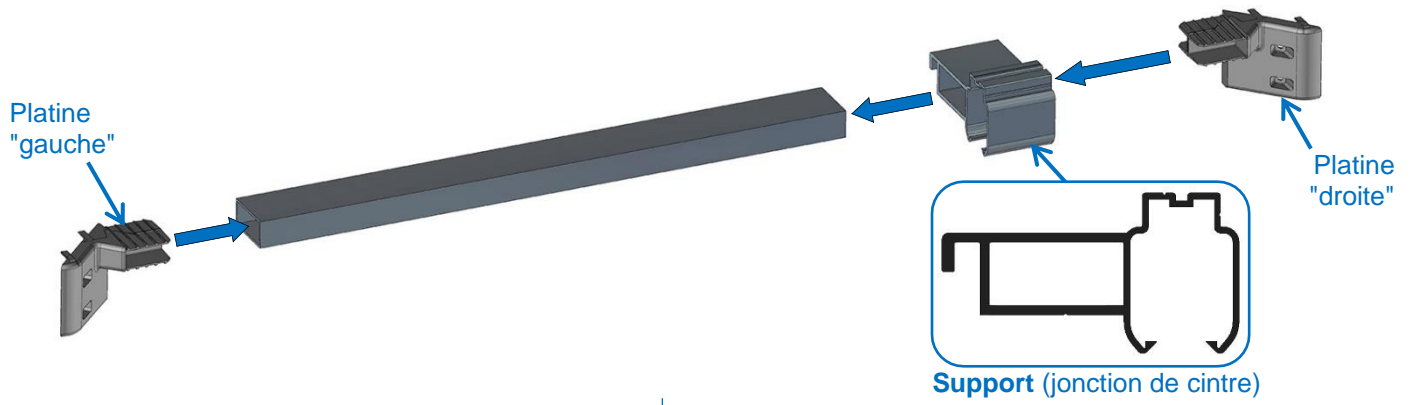

Assemblage du cintre

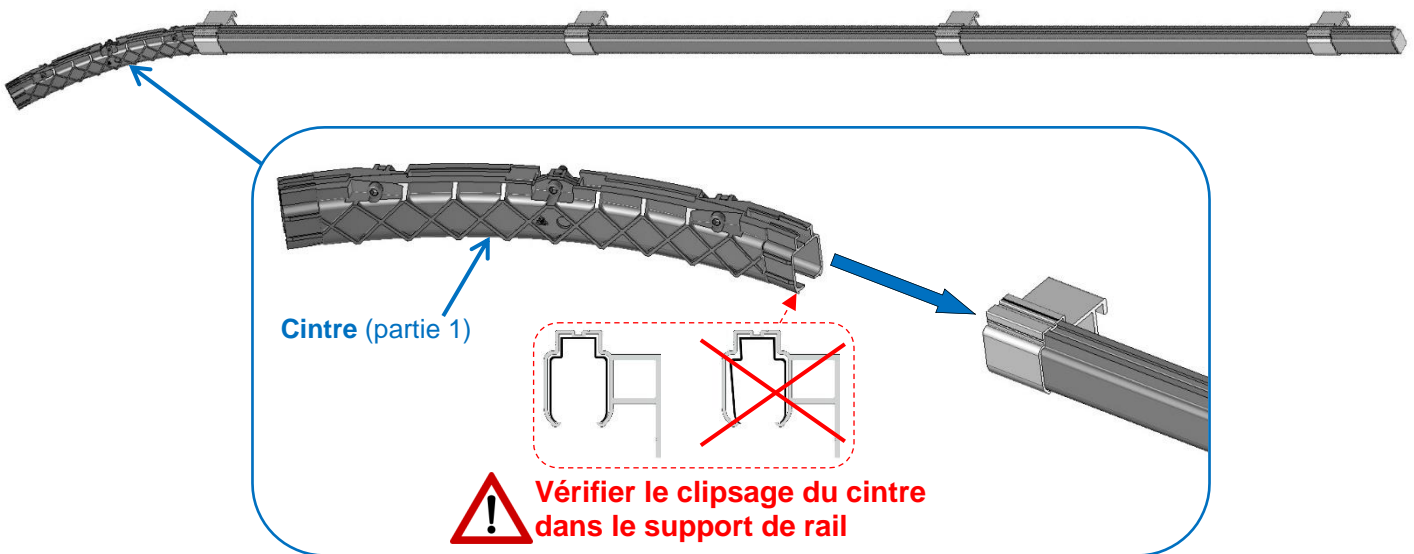

Montage du rail de guidage

• Rail en 1 partie :

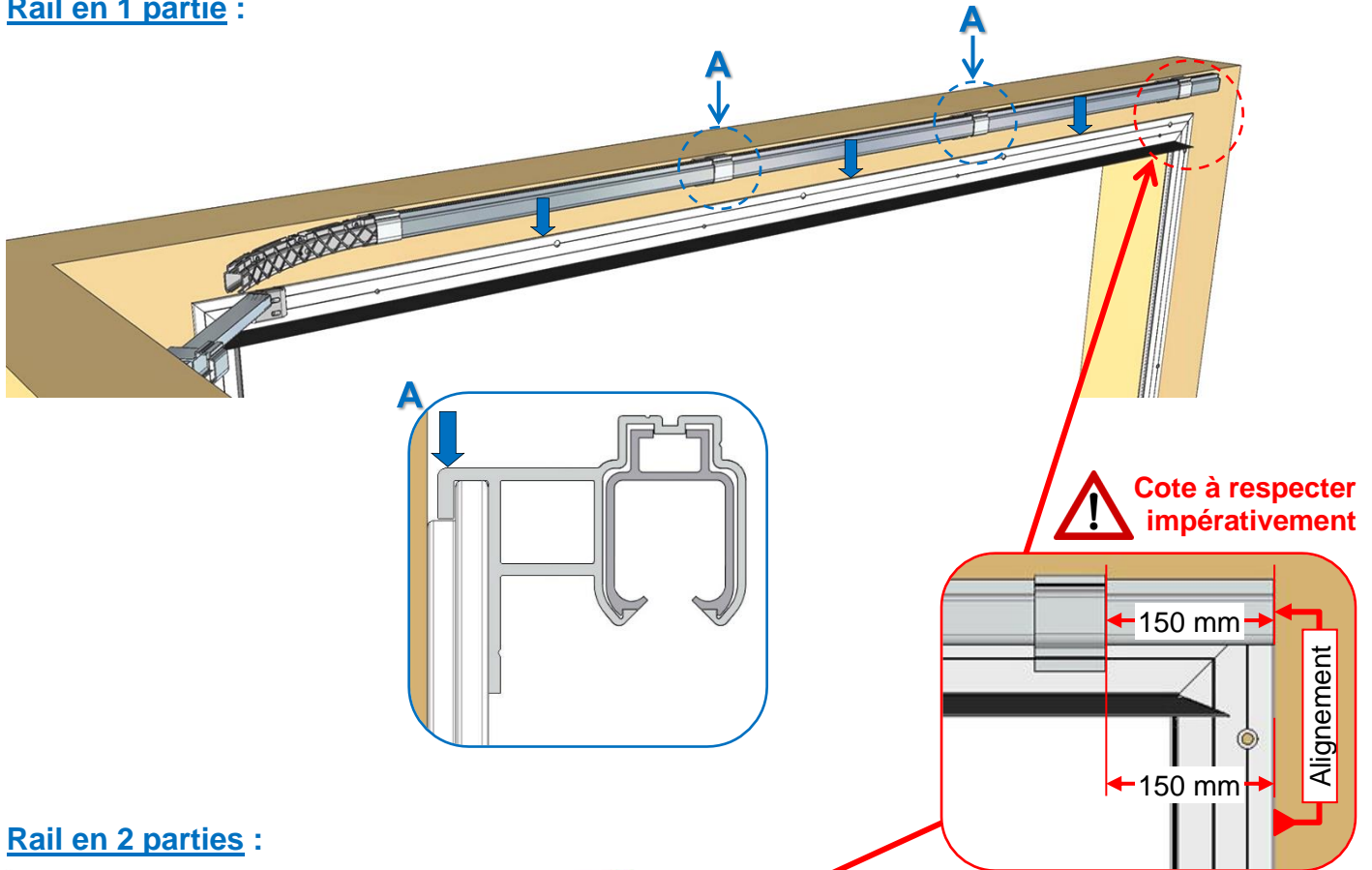

• Rail en 2 parties :

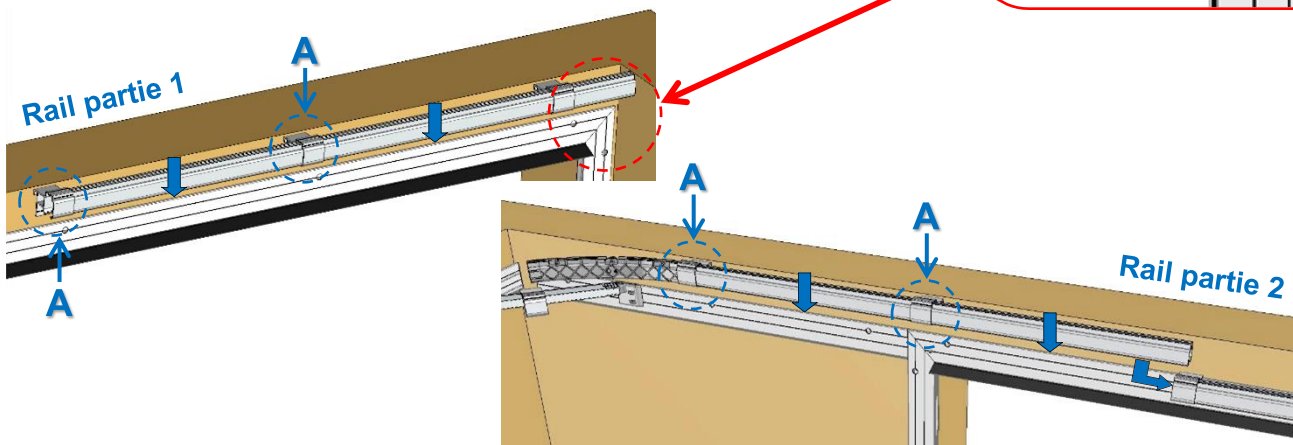

Fixation côté opposé au refoulement

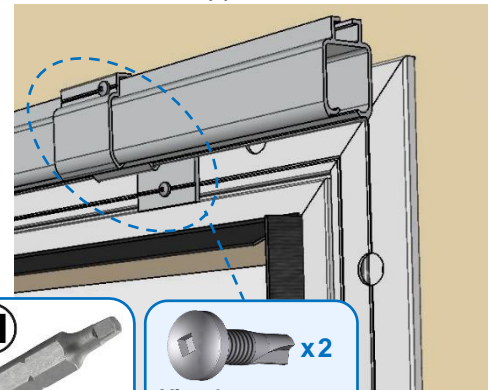

Assemblage du cintre (partie 2)

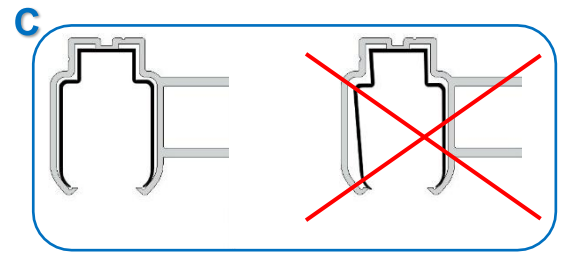
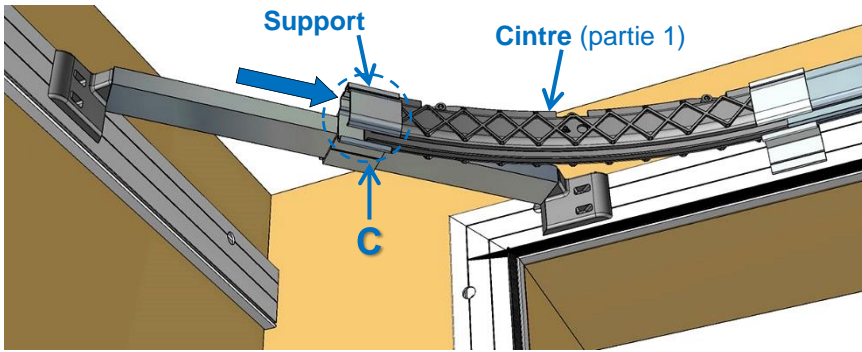

! Vérifier le clipsage du cintre dans les supports de rail

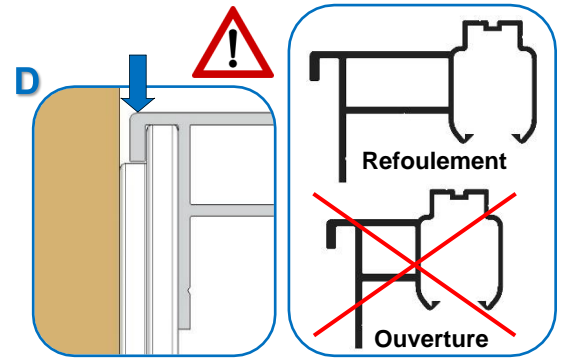
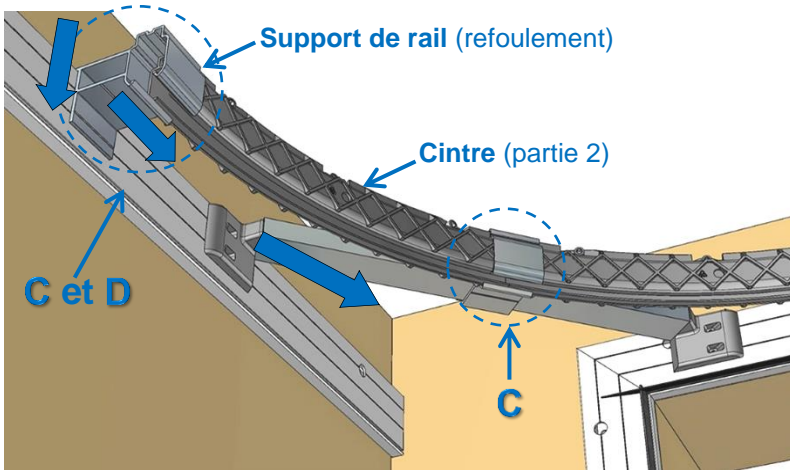

Fixer les 2 supports

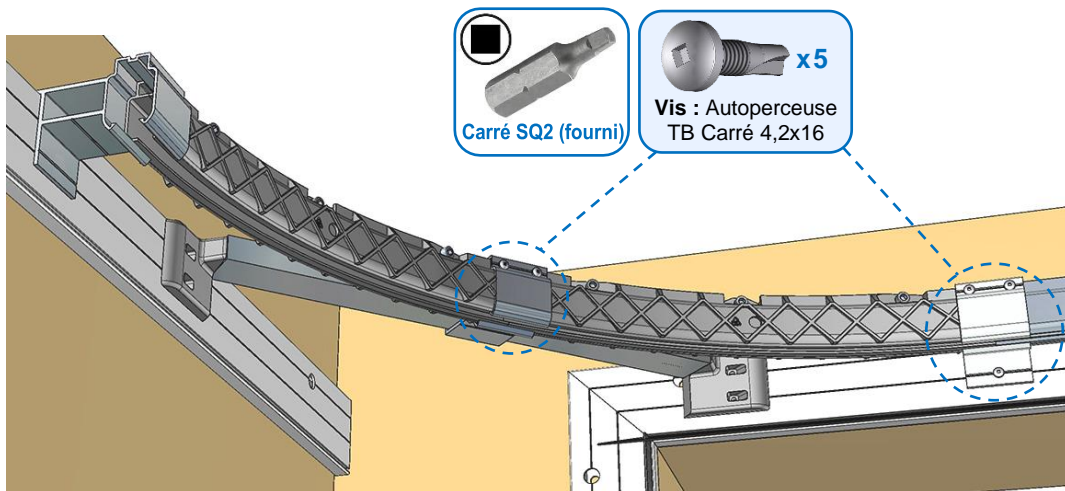

Butée tablier (Refoulement à gauche représenté)

Montage de la butée

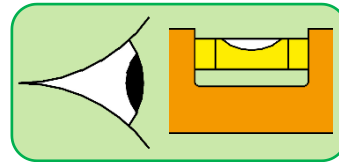
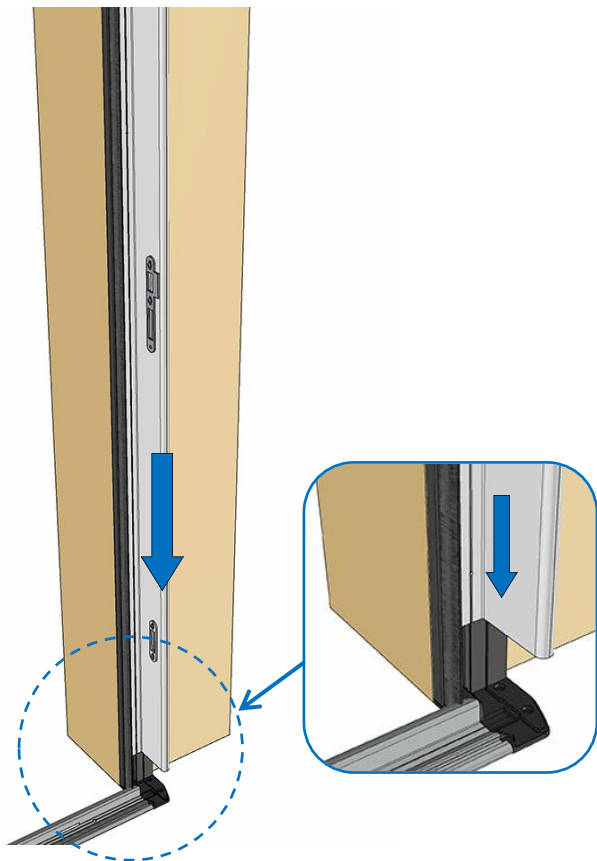
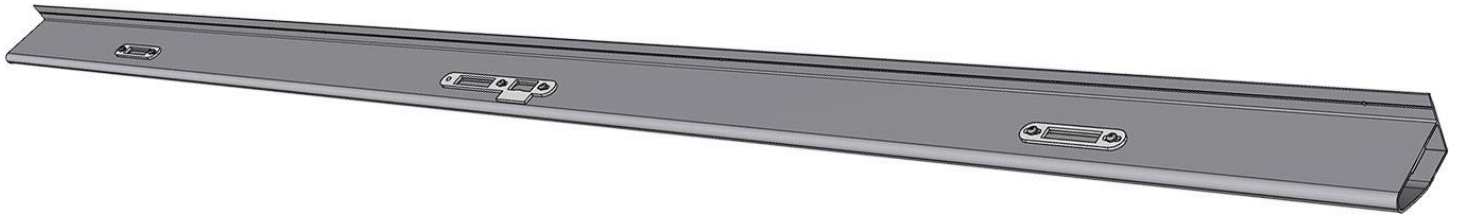

- 1- Plaquer le profilé contre le cadre
- 2- Mettre le profilé d'aplomb
- 3- Fixer le profilé à l'aide des vis

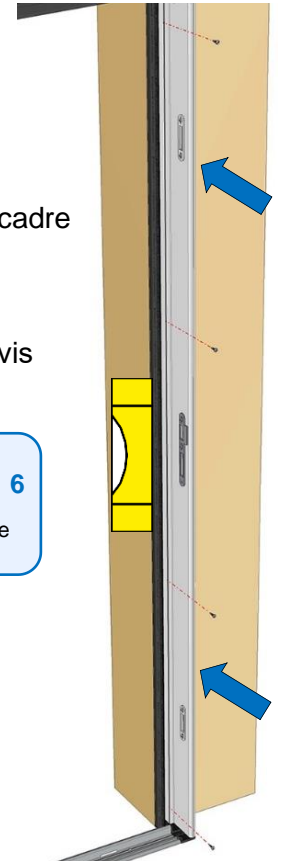

Avant de continuer, vous devez IMPÉRATIVEMENT contrôler :



- 1- Le cadre est parfaitement de niveau, d'aplomb et d'équerre.
- 2- Le cadre doit être parfaitement plan :
Eviter toute "vrille" liée aux imperfections de l'ossature.
- 3- Respectez la position du rail côté opposé au refoulement (cote de 150 mm).
- 4- Le seuil doit être parfaitement plan.

Tablier (Refoulement à gauche représenté)

Vue d'ensemble et montage de la poignée encastrée

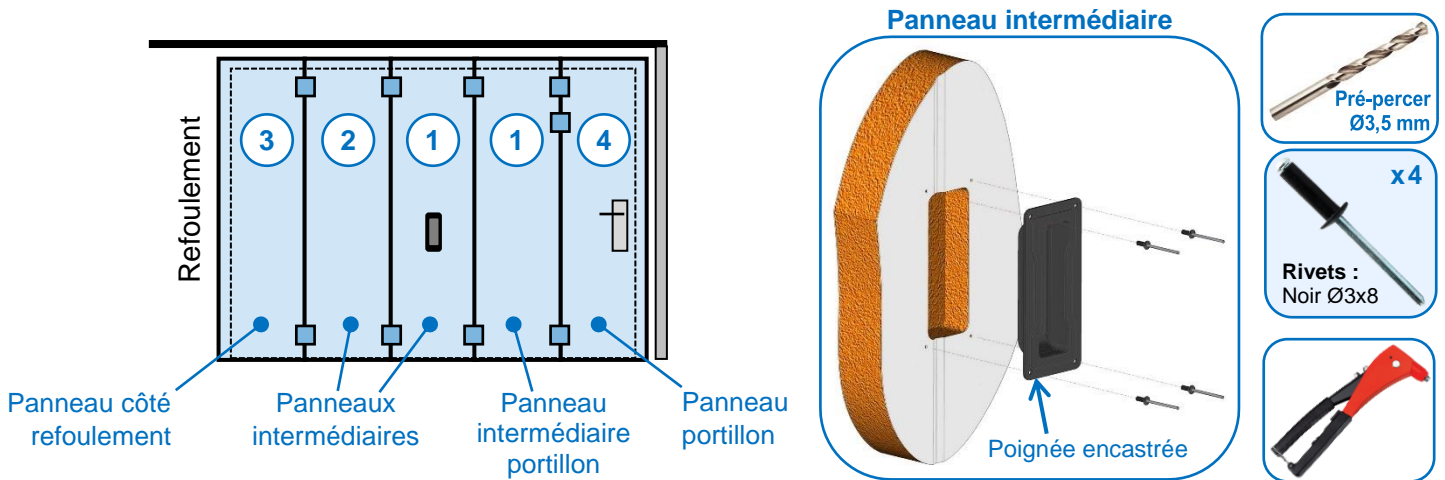

Préparation du panneau intermédiaire portillon

! Butée à plaquer sur le profil

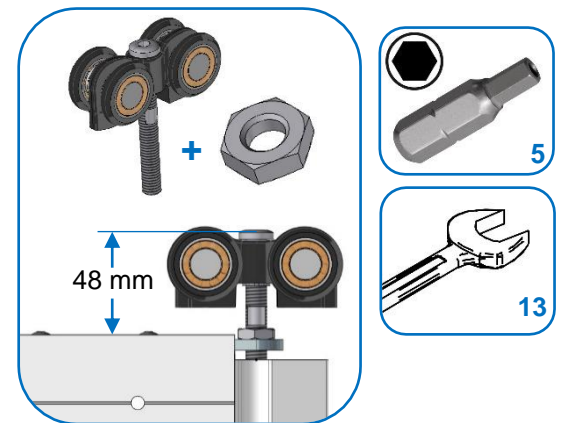
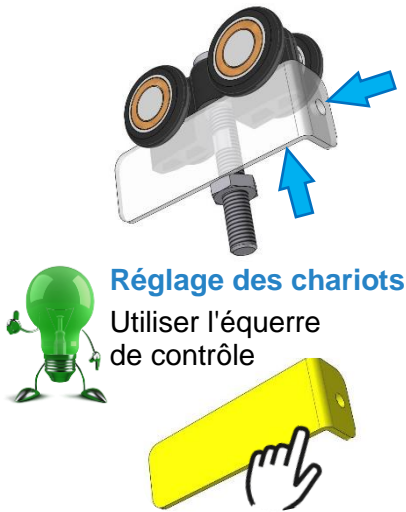
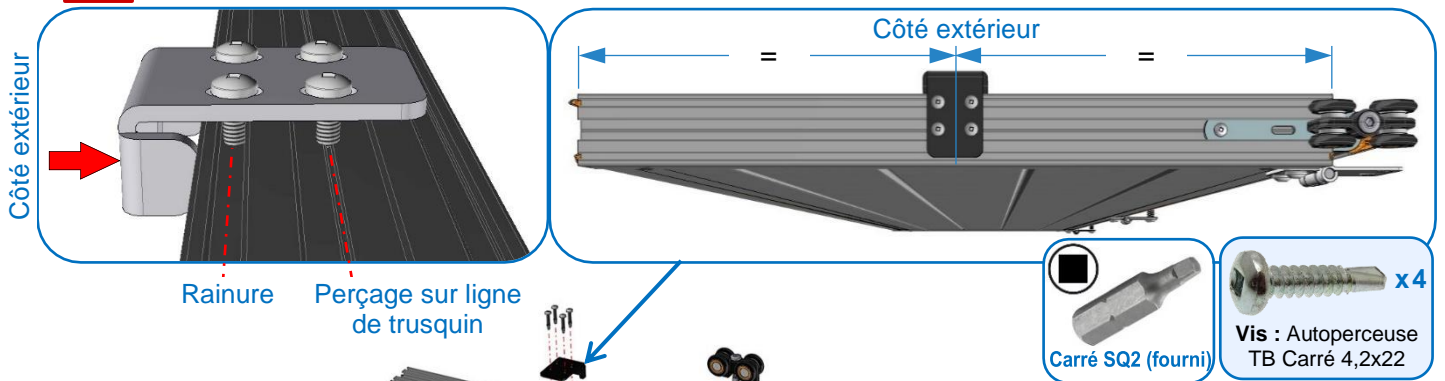

! Nœud de charnière dans la rainure du panneau

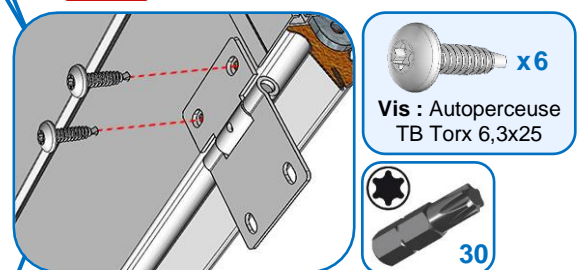

INFORMATION :

Les charnières seront retournées, lors de l'assemblage du portillon.

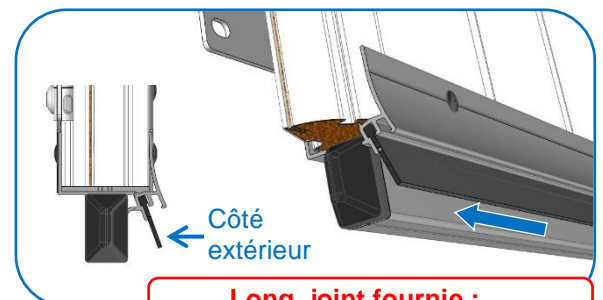
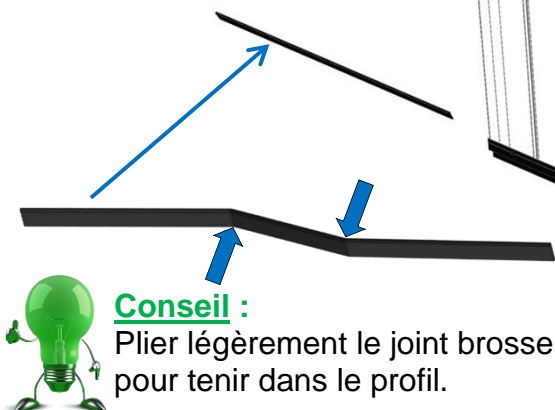

! Long. joint fournie :
 499 mm → Panneau 500 mm
 609 mm → Panneau 610 mm

Préparation des panneaux intermédiaires

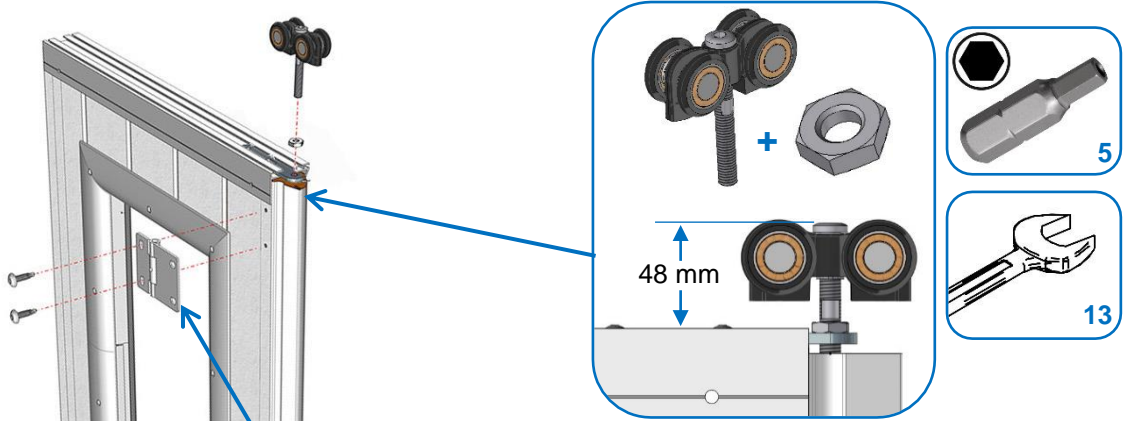

Réglage des chariots
Utiliser l'équerre de contrôle

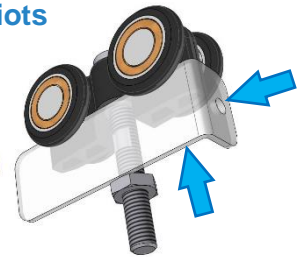
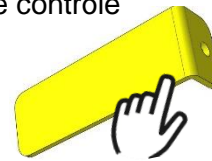

Vue intérieure

⚠ Nœud de charnière dans la rainure du panneau

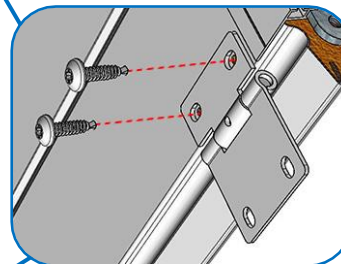

Vis : Autoperceuse TB Torx 6,3x25 x4

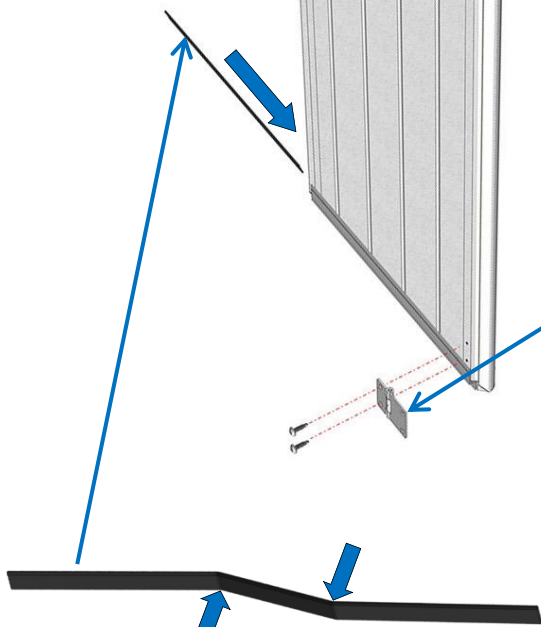

Conseil :
Plier légèrement le joint brosse pour tenir dans le profil.

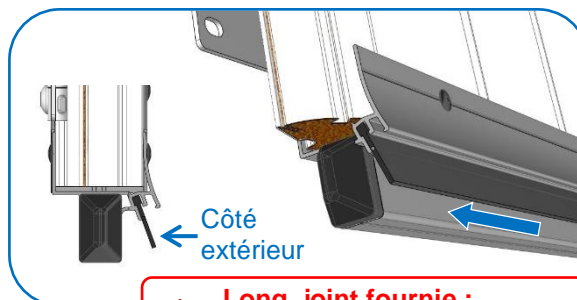

⚠ Long. joint fournie :
499 mm → Panneau 500 mm
609 mm → Panneau 610 mm

Assemblage des panneaux intermédiaire portillon & intermédiaire "poignée"

• Positionnement & alignement des panneaux :



! Contact panneaux/charnières

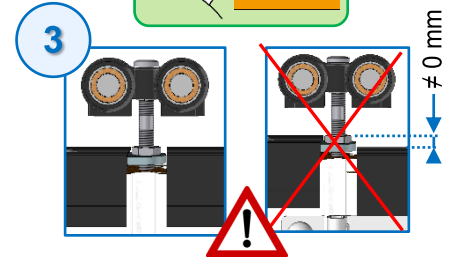
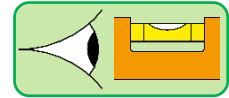
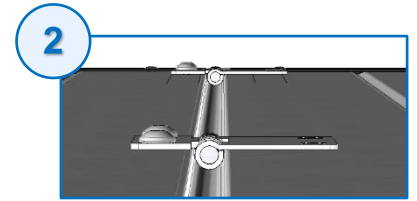

• Fixation des charnières :

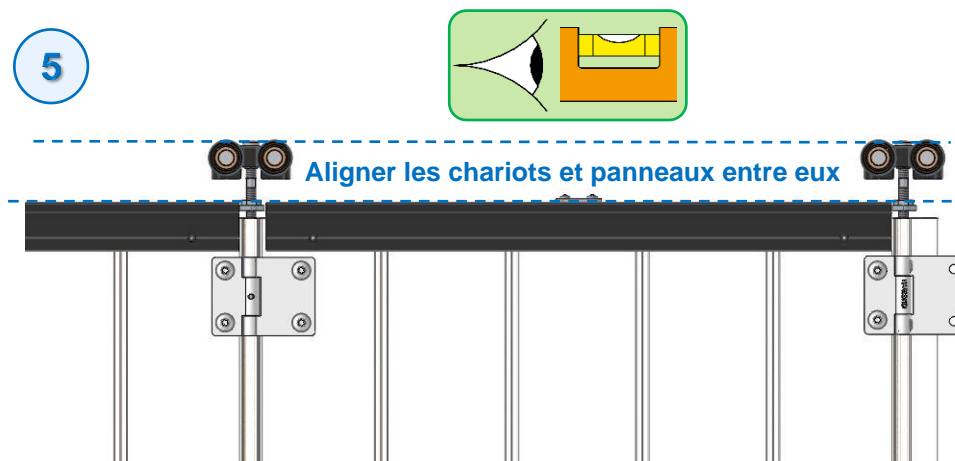
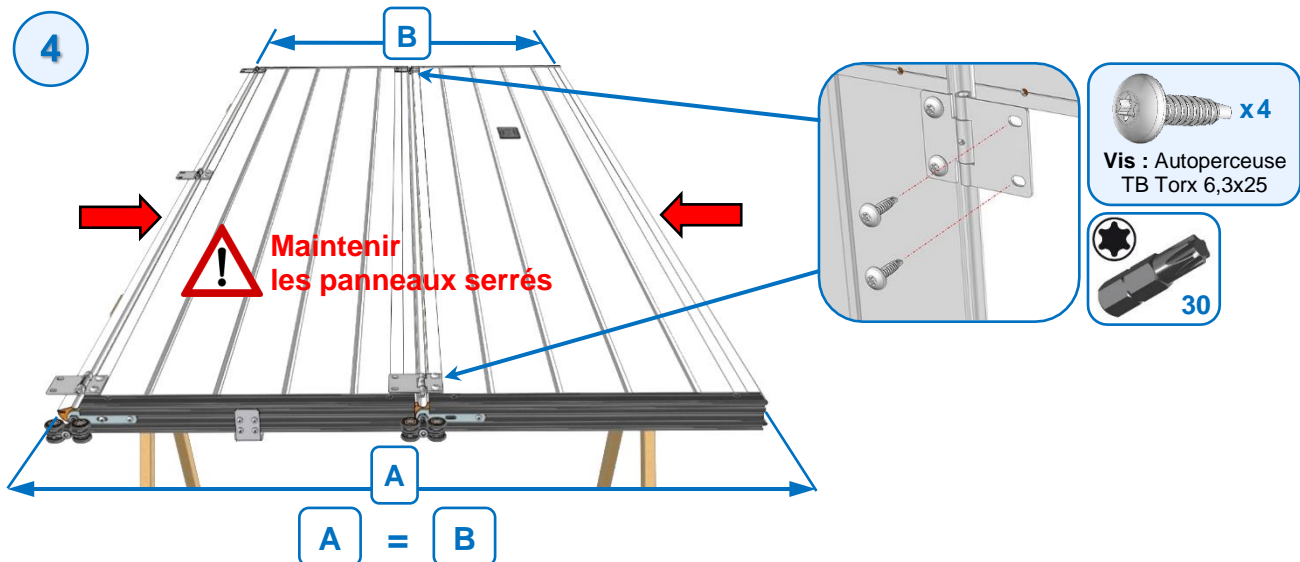

Installation des panneaux intermédiaire portillon & intermédiaire "poignée"

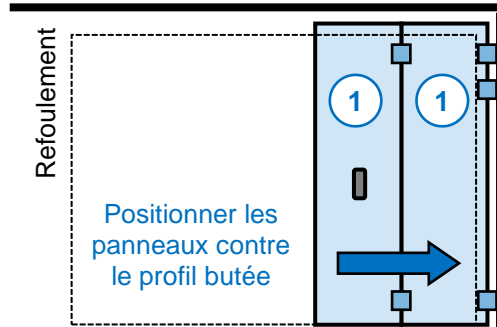
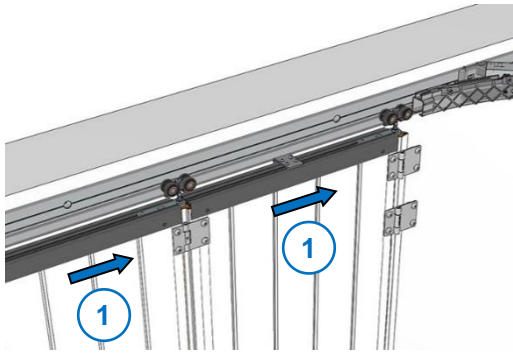

Contrôler le niveau des 2 panneaux

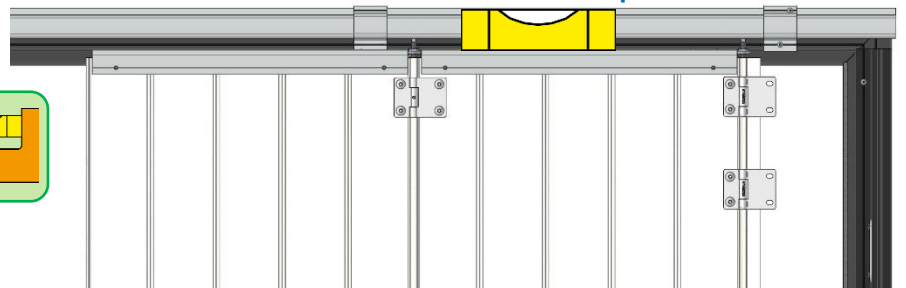
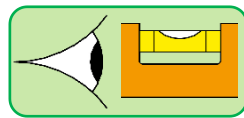

Contrôler la cote entre profil bas/seuil sur toute la longueur du seuil

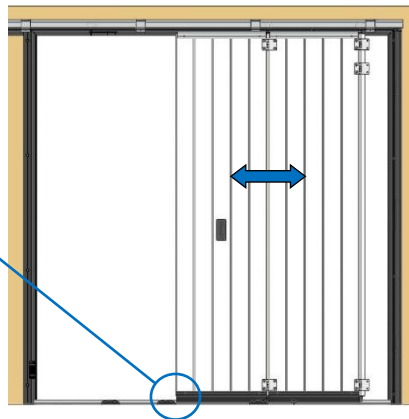
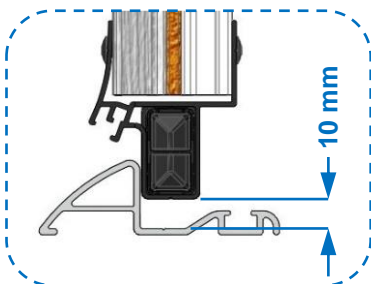

Tolérance : 10 mm +3/-2
Si valeur inférieure à 8 mm,
remonter le tablier d'autant.

Préparation du panneau côté refoulement

Système de placage

Si ECR \geq 225 mm

Glisser la double clame dans le profil vertical

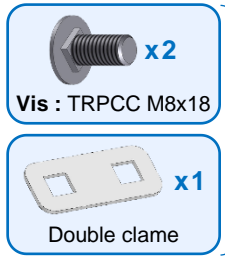

Si HP > 2500 mm

2 systèmes de placage

Régler le support chariot



Trou taraudé à l'extérieur

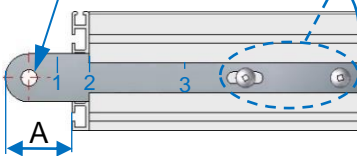

ECR (mm)	Position	A (mm)
$300 \leq \text{ECR} < 500$	2	28
$500 \leq \text{ECR} \leq 585$	3	63
Si ECR > 585 monter le chariot	1	16

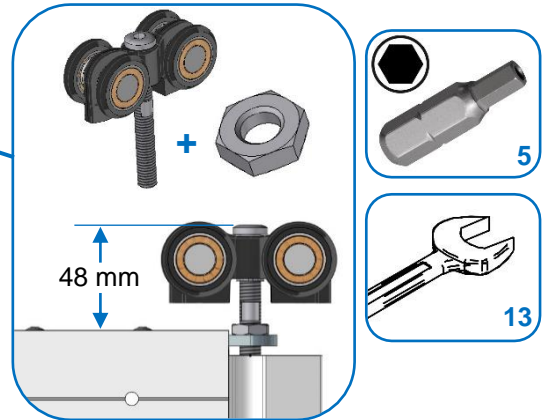

Réglage des chariots

Utiliser l'équerre de contrôle

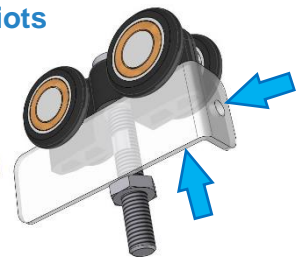
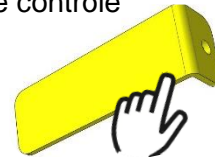

Vue intérieure



Nœud de charnière dans la rainure du panneau

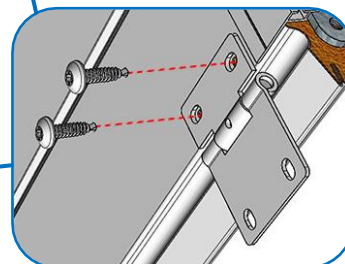

• **Monter les butées caoutchouc : $300 \leq ECR \leq 585$ mm**

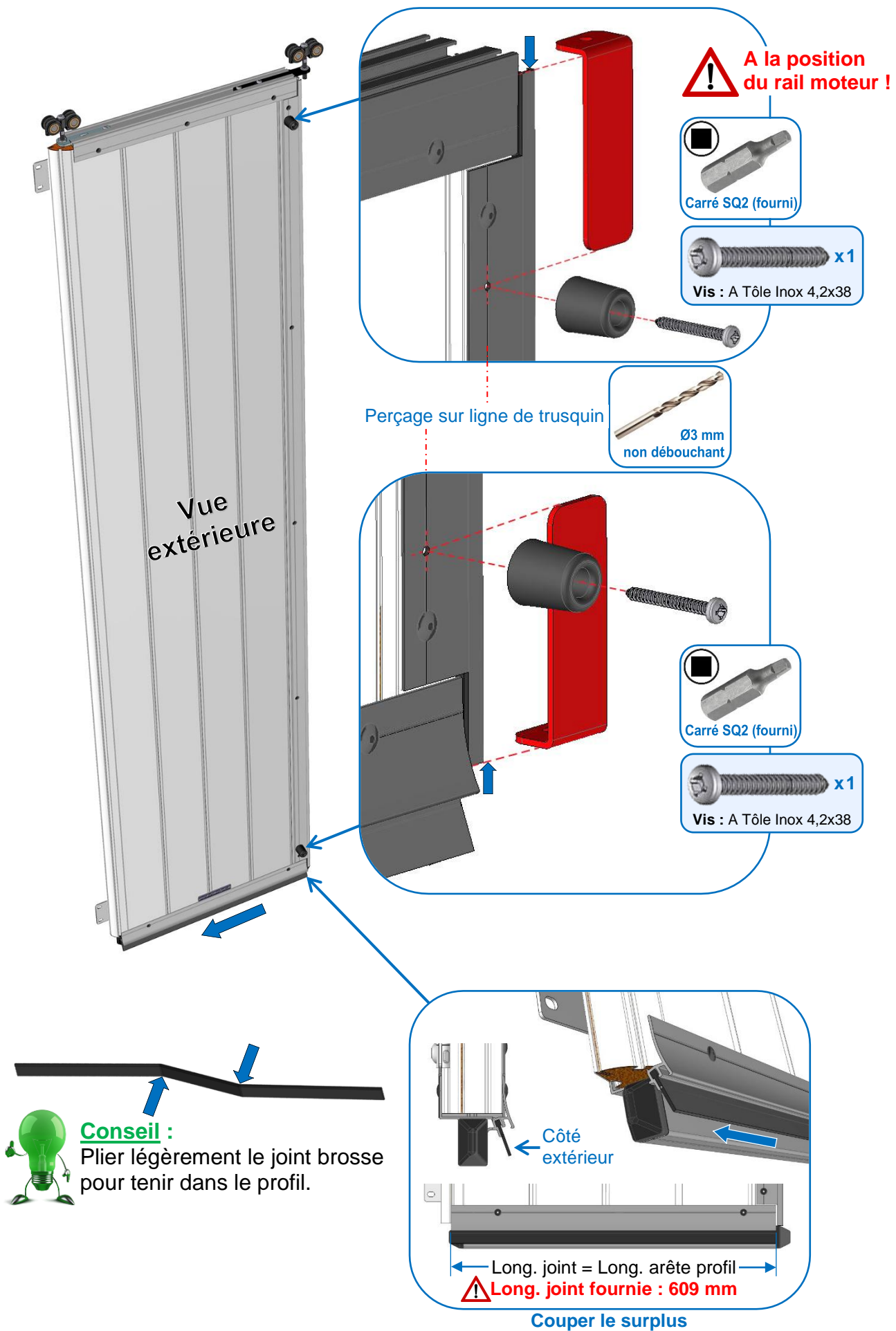

Installation des panneaux intermédiaires par 2 ou avec panneau côté refoulement

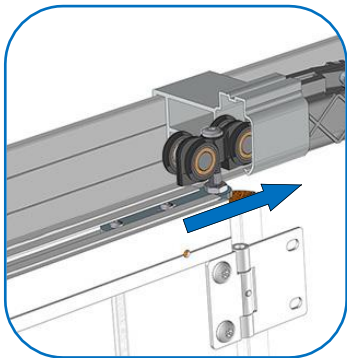

Positionner les panneaux dans la baie suivant l'ordre de montage

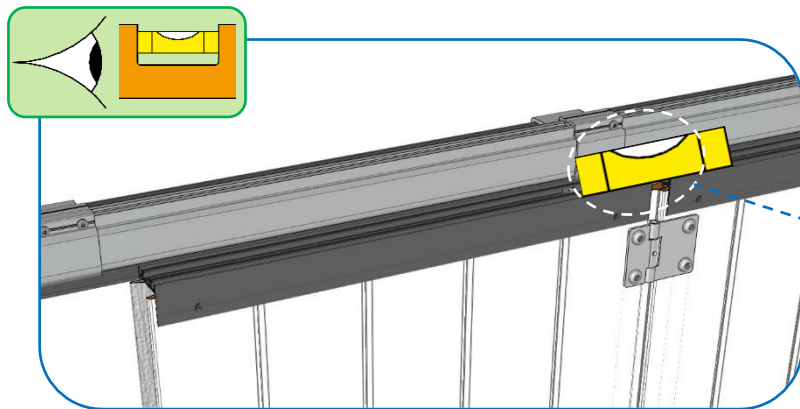
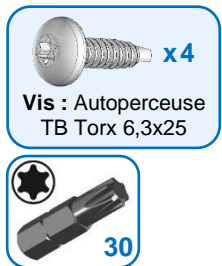
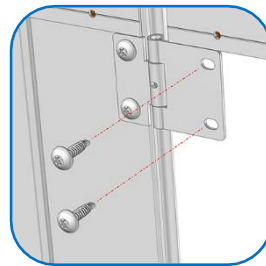
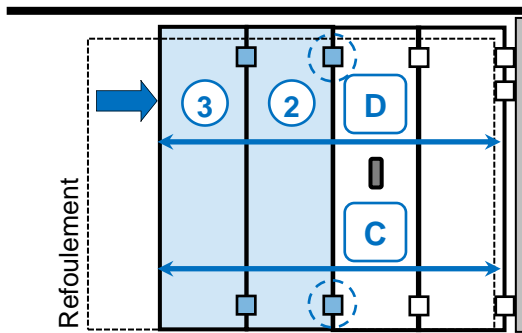

Réglage du chariot

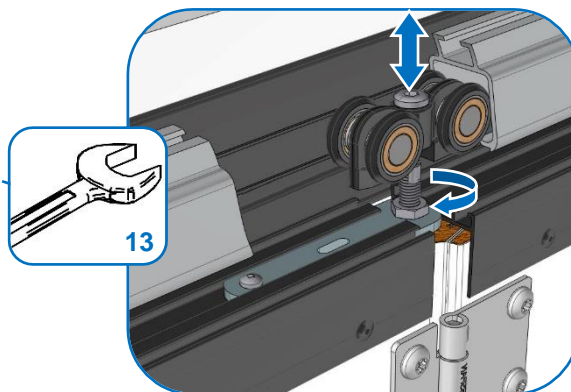

Contrôler la cote entre profil bas/seuil sur toute la longueur du seuil



Tolérance : 10 mm +3/-2
Si valeur inférieure à 8 mm, remonter le tablier d'autant.

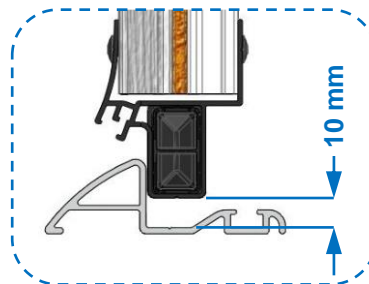

Contrôler la position du tablier

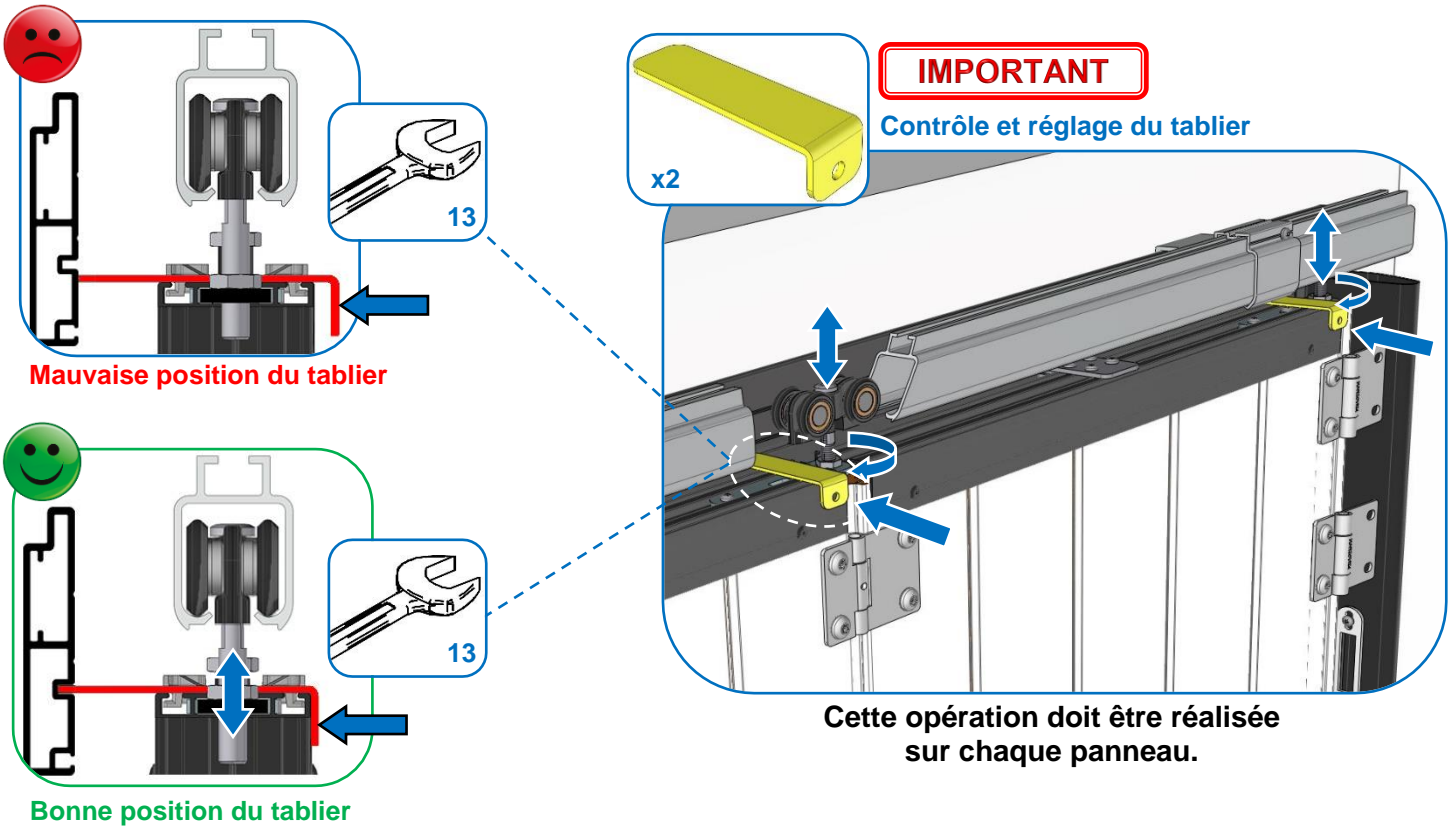

Contrôler le niveau sur tout le tablier

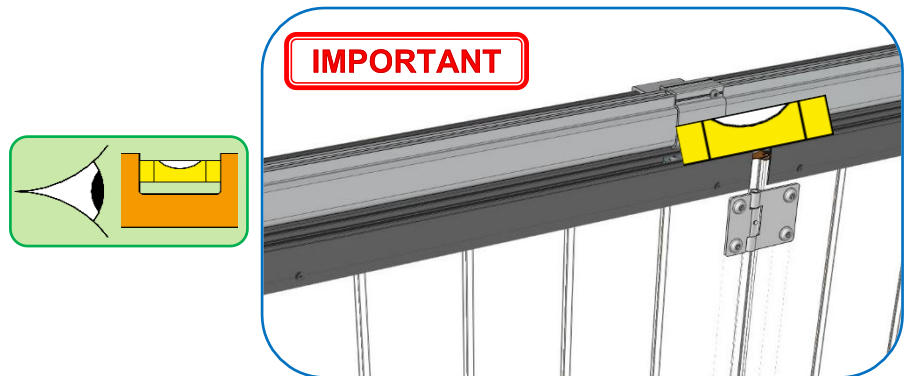

Contrôler le parallélisme

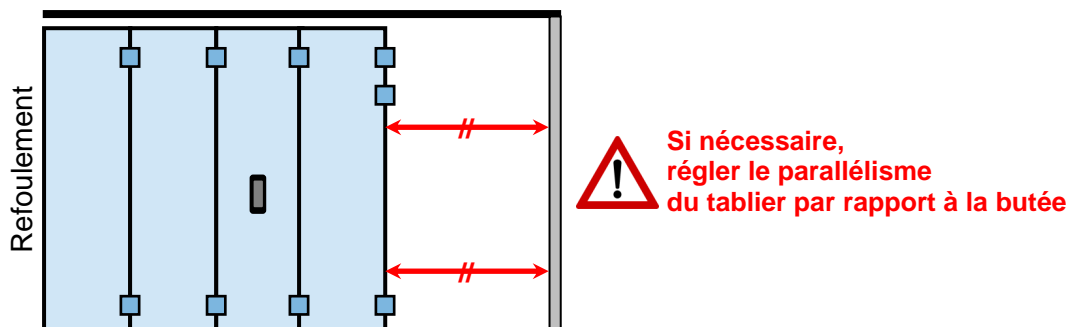

Préparation du panneau portillon

• Installation de la butée :

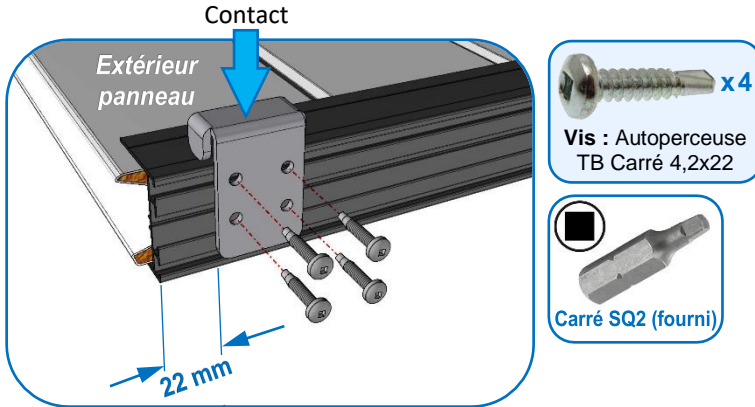

• Montage des béquilles et du canon :

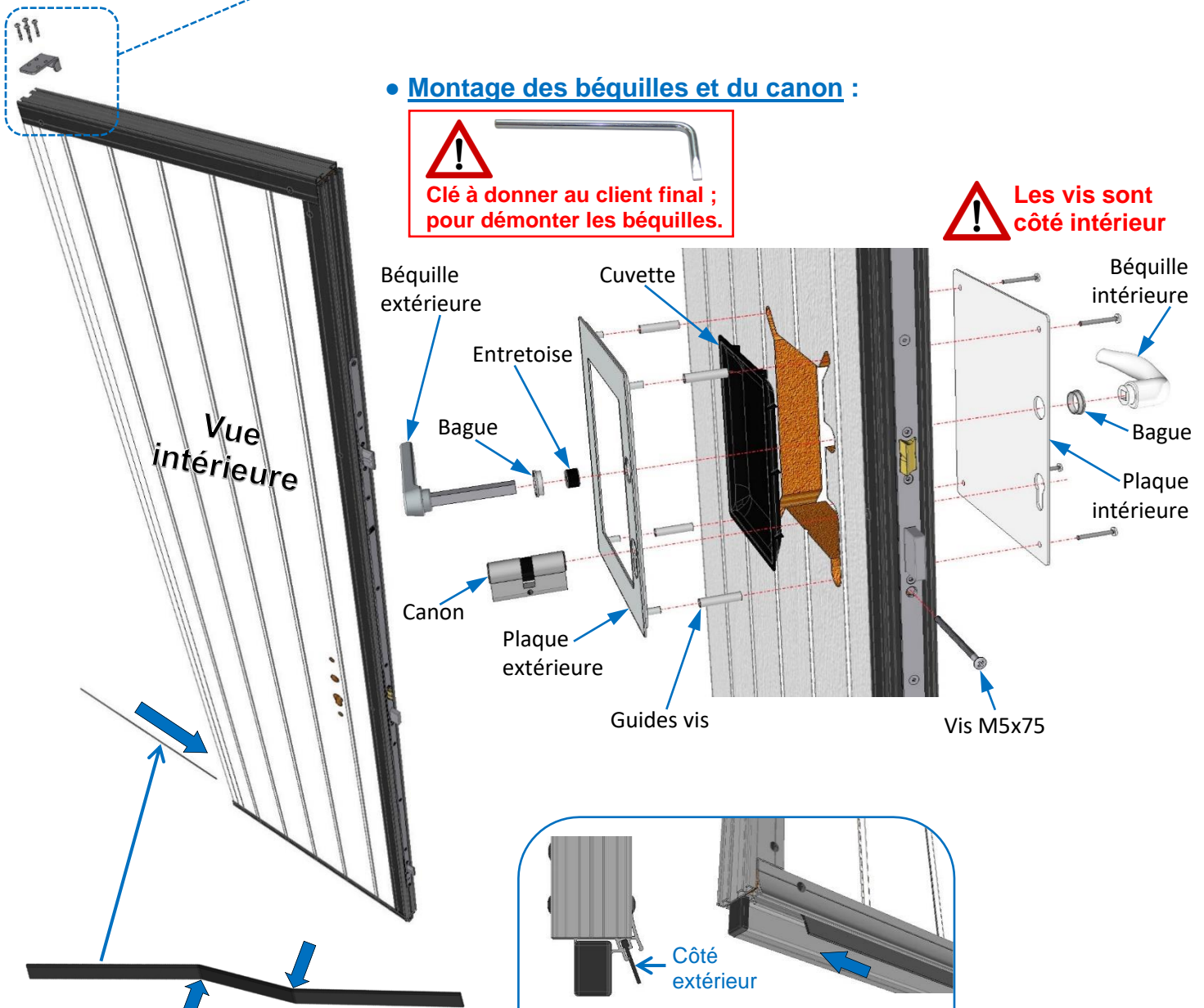
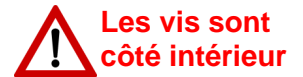

Conseil :
Plier légèrement le joint brosse pour tenir dans le profil.

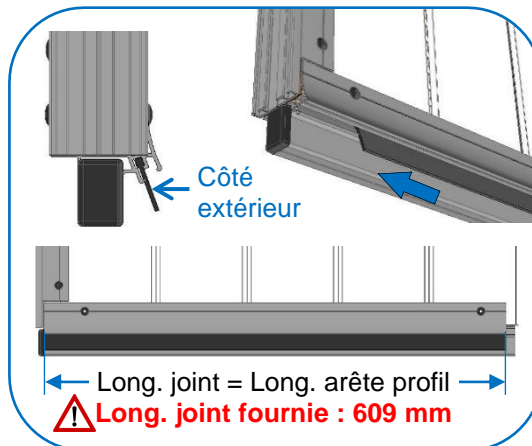

Couper le surplus

Installation du panneau portillon

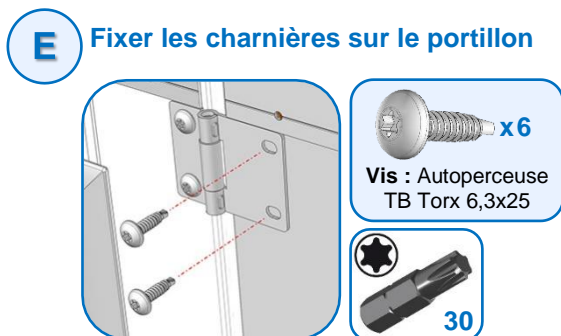
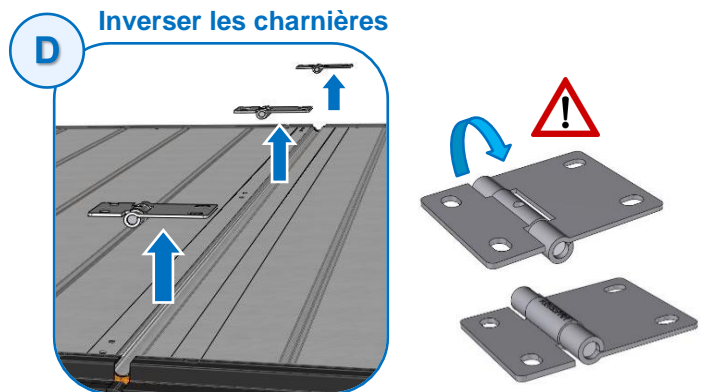
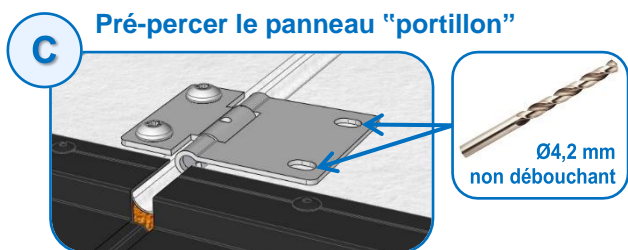
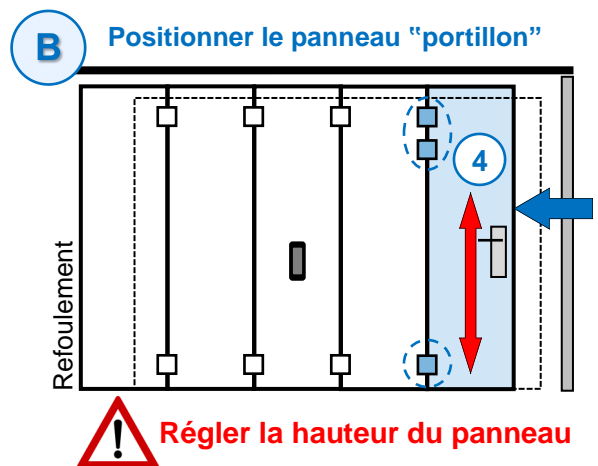
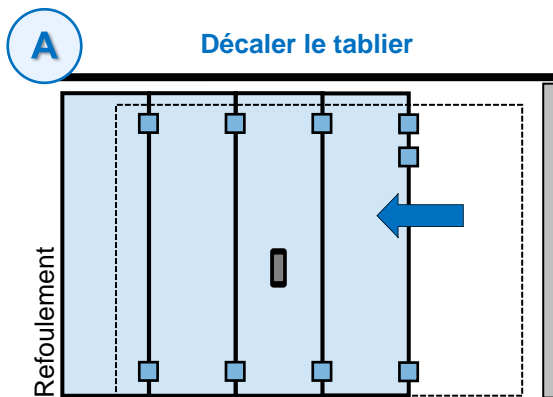
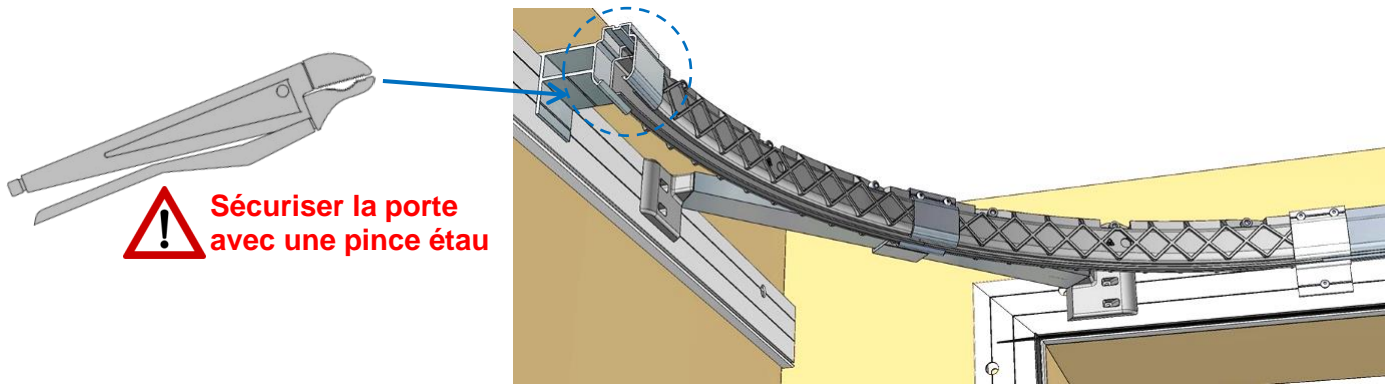

! Nœud de charnière hors de la rainure du panneau

Assemblage du "rail de guidage haut" sur le sol

• **Rail en 1 partie :**

OU

• **Rail en 2 parties :**

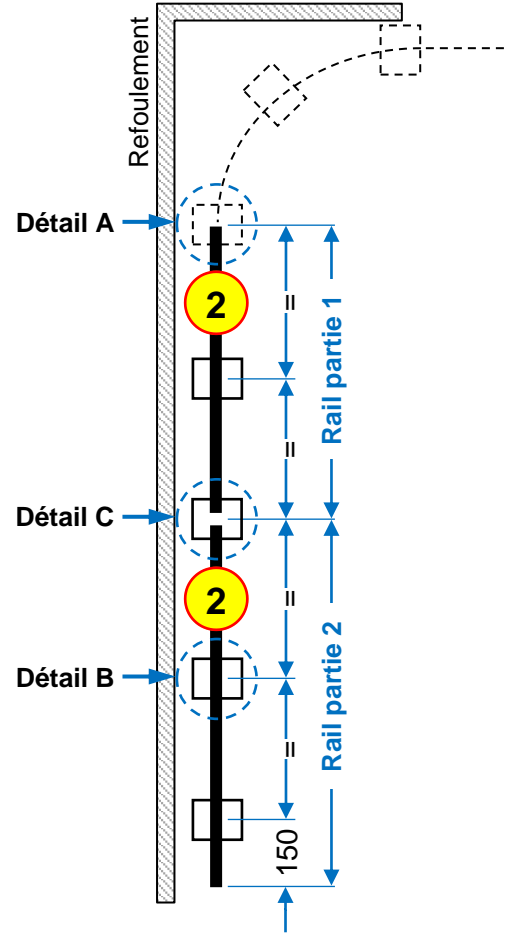
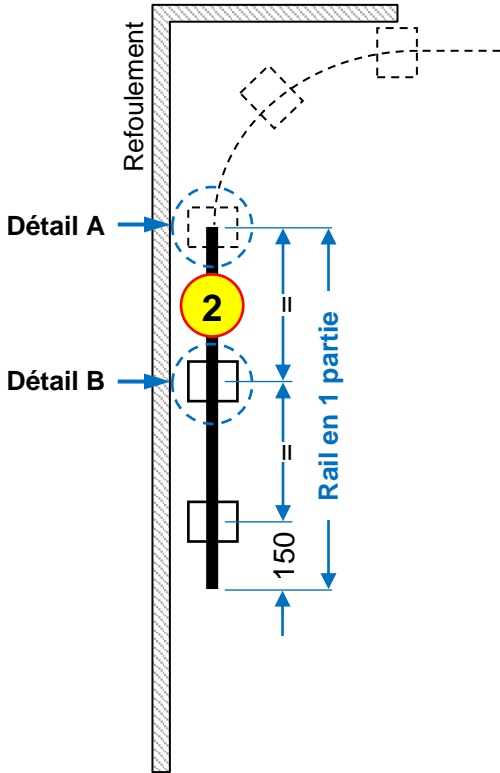

Profilé

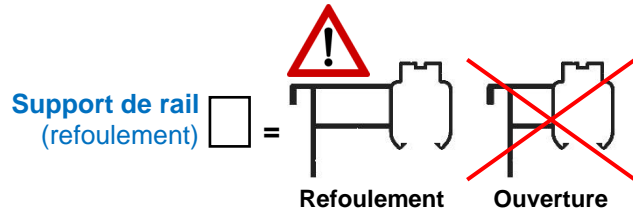
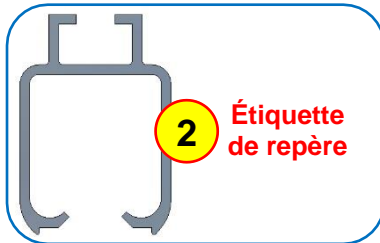

Détail A

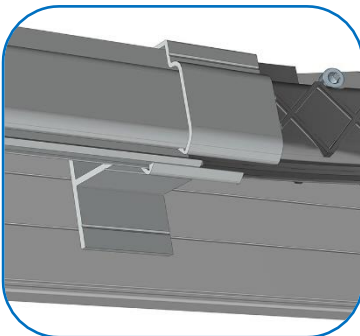

Détail B

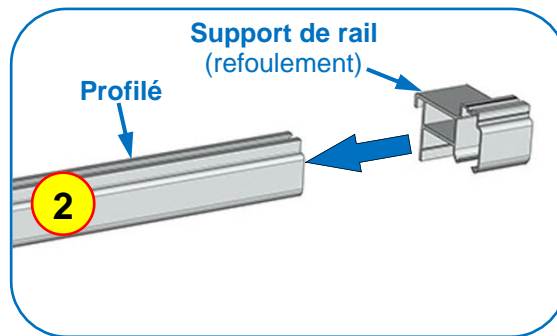

Détail C

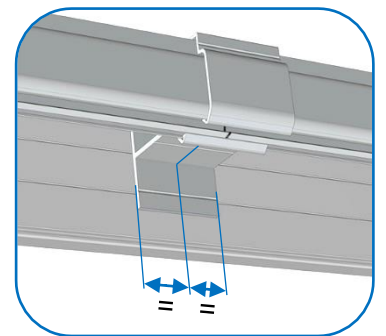

Montage du rail de guidage

• Rail en 1 ou 2 parties :

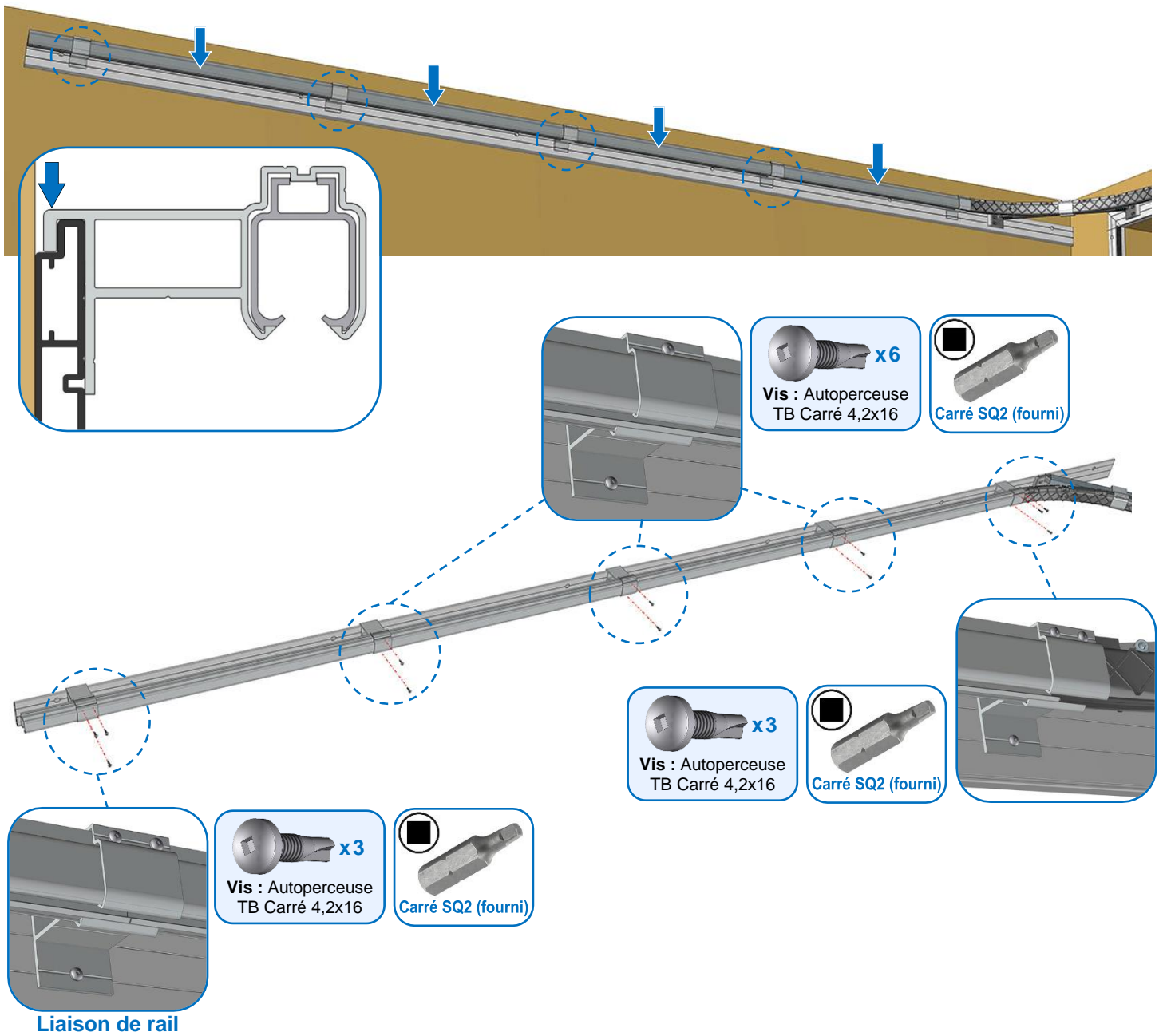

Les différents équipements côté refoulement

3 cas possibles (Refoulement à gauche représenté)

- **Bras multiposition** : $300 \text{ mm} \leq \text{ECR}^* \leq 585 \text{ mm}$ (détail du montage sur les pages suivantes).

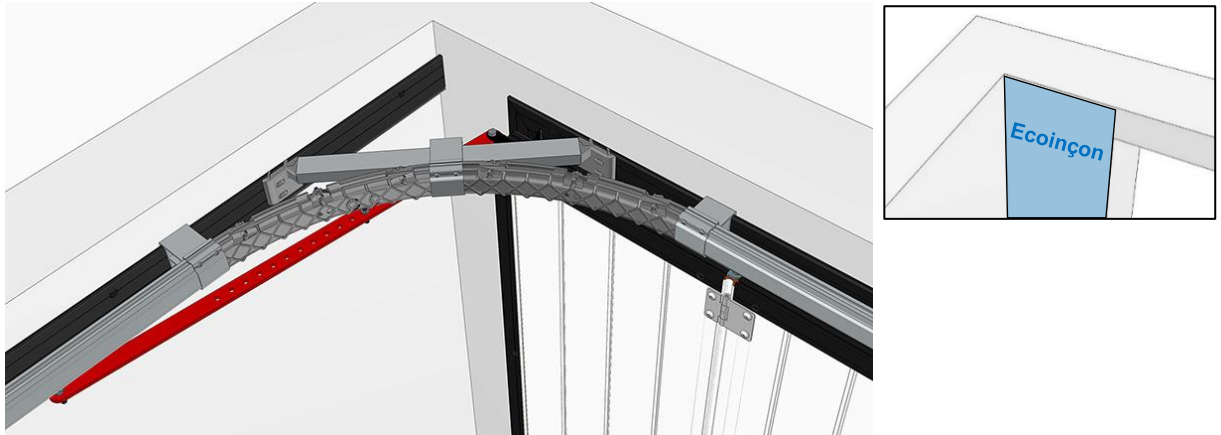

- **Rallonge** : $585 \text{ mm} < \text{ECR}^* \leq 650 \text{ mm}$ (détail du montage sur les pages suivantes).

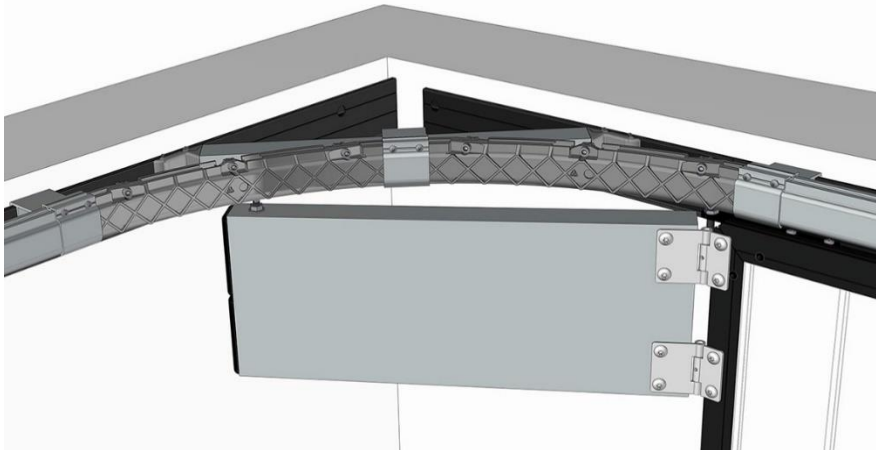

- **Pas d'équipement** : $\text{ECR}^* > 650 \text{ mm}$ (détail sur les pages suivantes).

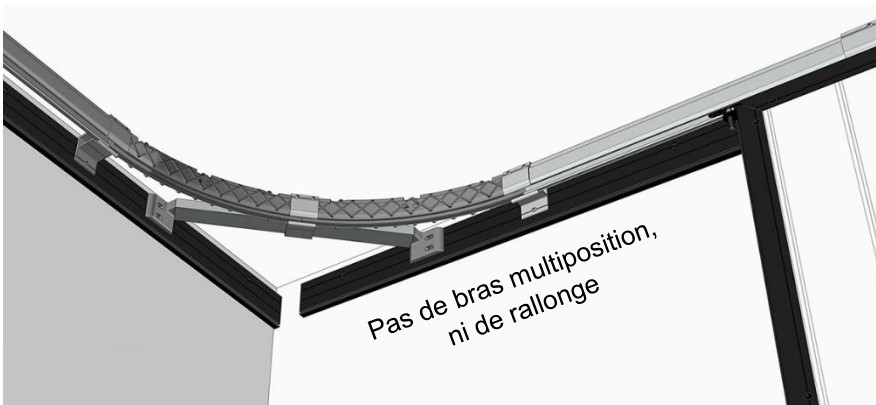

* ECR = Ecoinçon Côté Refoulement

Bras multiposition pour écoinçon : $300 \leq ECR \leq 585$ mm

Montage du bras

- Glisser les 2 chariots dans le rail de guidage :

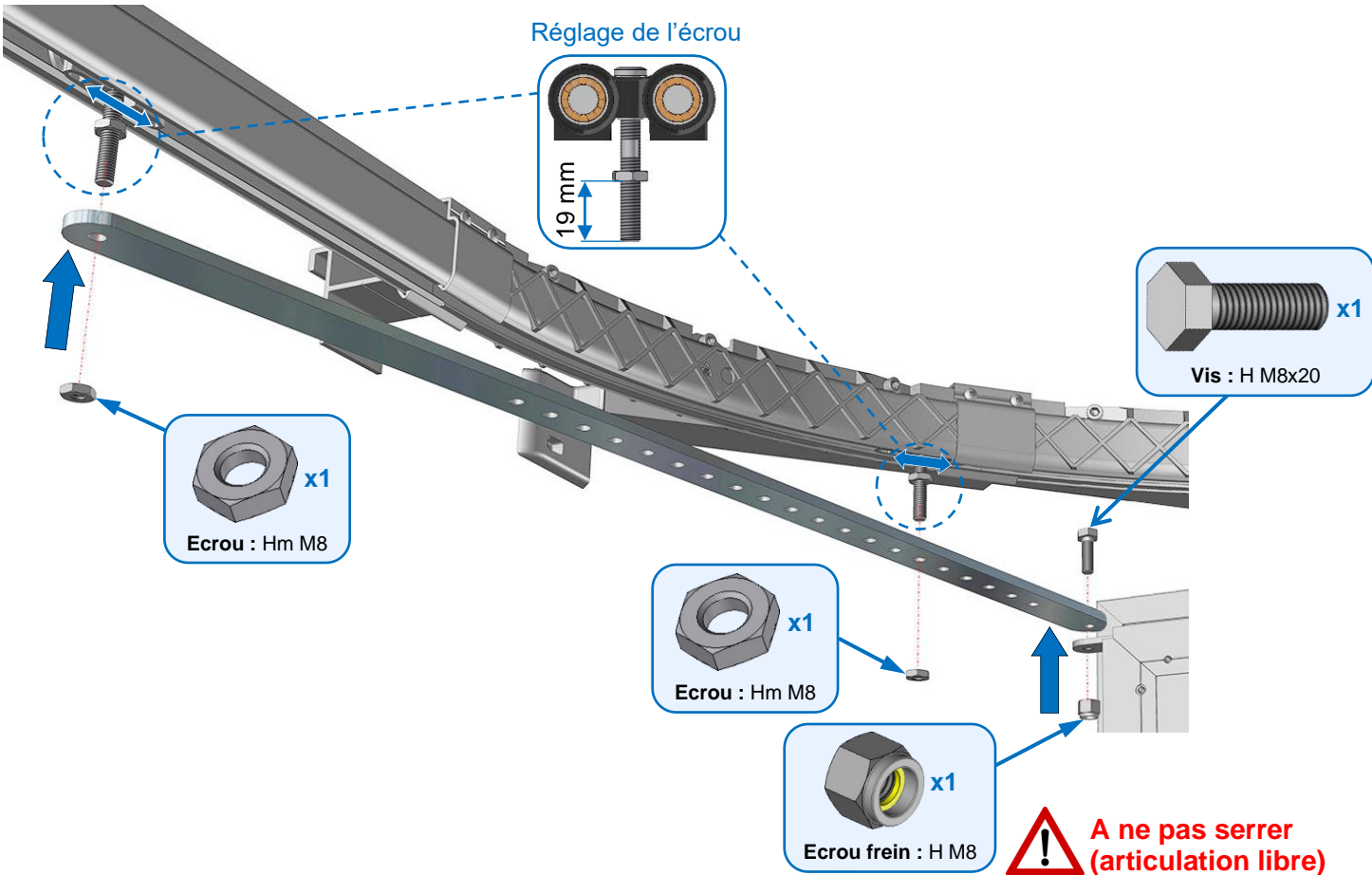
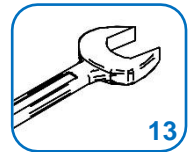

- Monter le bras en fonction de l'écoinçon (Valeur théorique : A ajuster sur chantier)

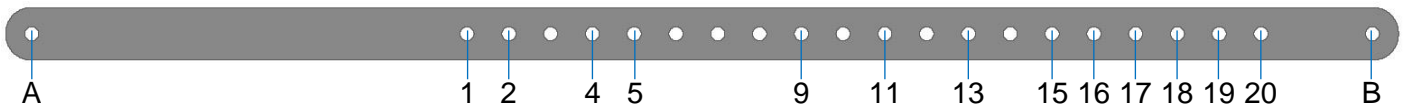

Extrémités du bras	Bras entier			Bras recoupé								
	A et B			B et 2	B et 4	B et 4	B et 1	B et 5	B et 9	B et 11	B et 13	B et 16
* N° du trou	15	17	19	19	18	19	20	20	20	20	20	20
Ecoinçon (mm)	300	350	400	415	425	450	500	515	535	550	560	585

* Dans le cas d'un écoinçon tombant entre 2 numéros de trous, prendre le numéro du trou inférieur.

Rallonge pour écoinçon : $585 < ECR \leq 650$ mm

Préparation de la rallonge

IMPORTANT : Ecrou H bas à embase M8

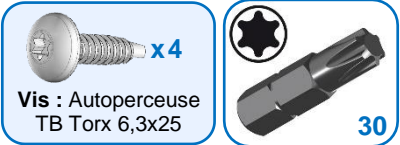
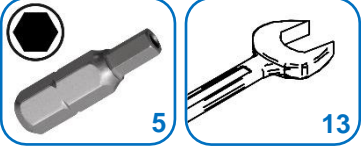

Montage de la rallonge

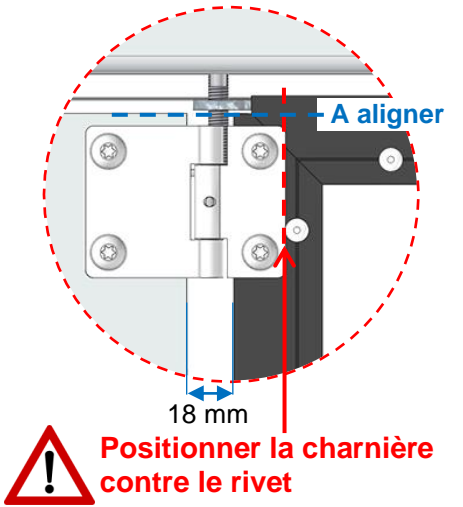
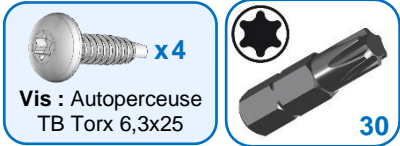
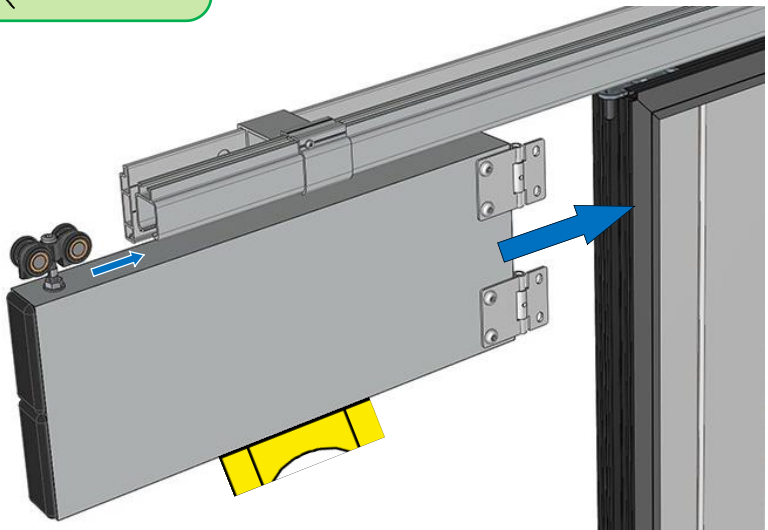
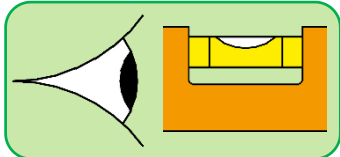

Pas d'équipement pour écoinçon : ECR > 650 mm

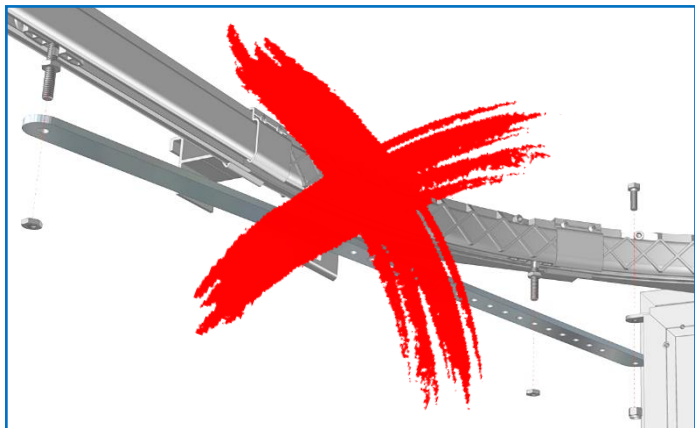

Pas de bras multiposition

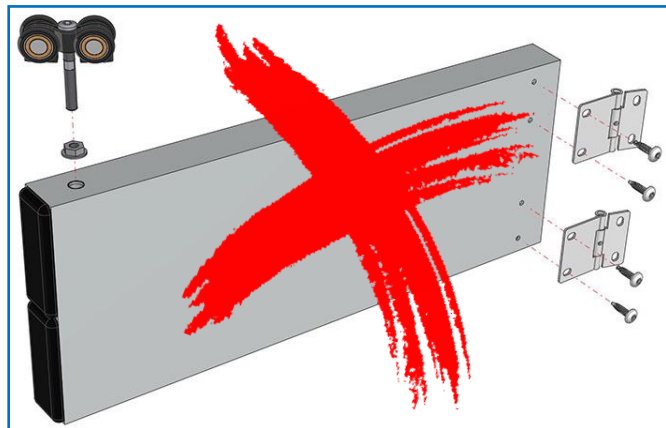

Pas de rallonge

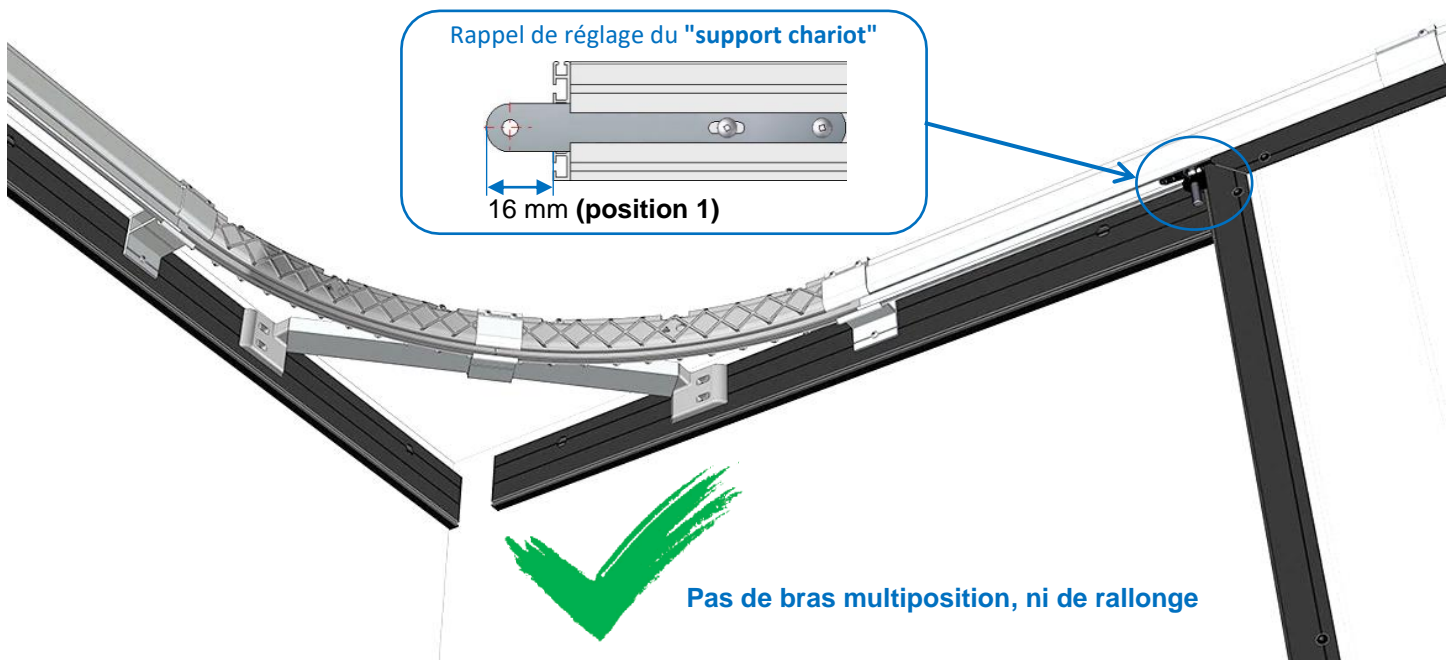

Rappel de réglage du "support chariot"

16 mm (position 1)

Pas de bras multiposition, ni de rallonge

Finitions pour tous les types d'écoinçons

Montage de la butée de fin de course

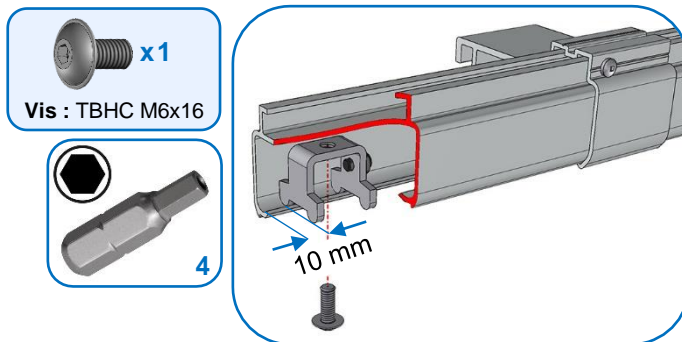

x1

Vis : TBHC M6x16



4

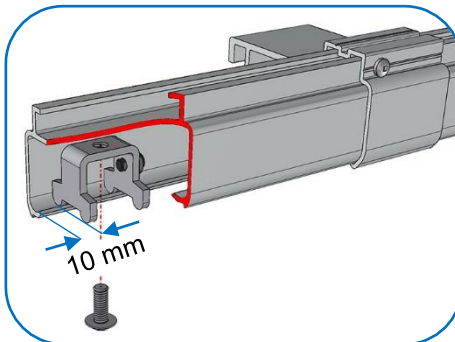

10 mm

Montage des butées fixes

• Préparation de la butée "Tablier" :

Refoulement à gauche

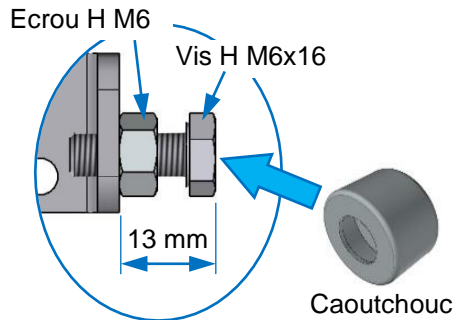
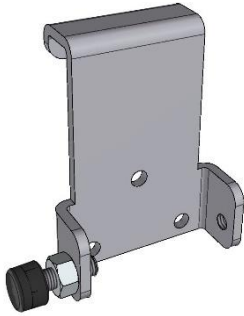

Refoulement à droite

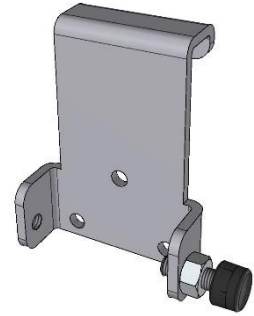

• Installation de la butée "Tablier" : Fermer le tablier en respectant le jeu théorique ci-dessous.

IMPORTANT

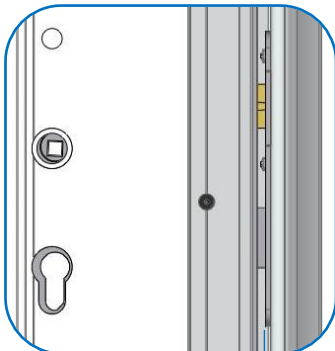

Jeu théorique = 4 mm
entre la tête et la gâche
(utiliser les cales fournies)

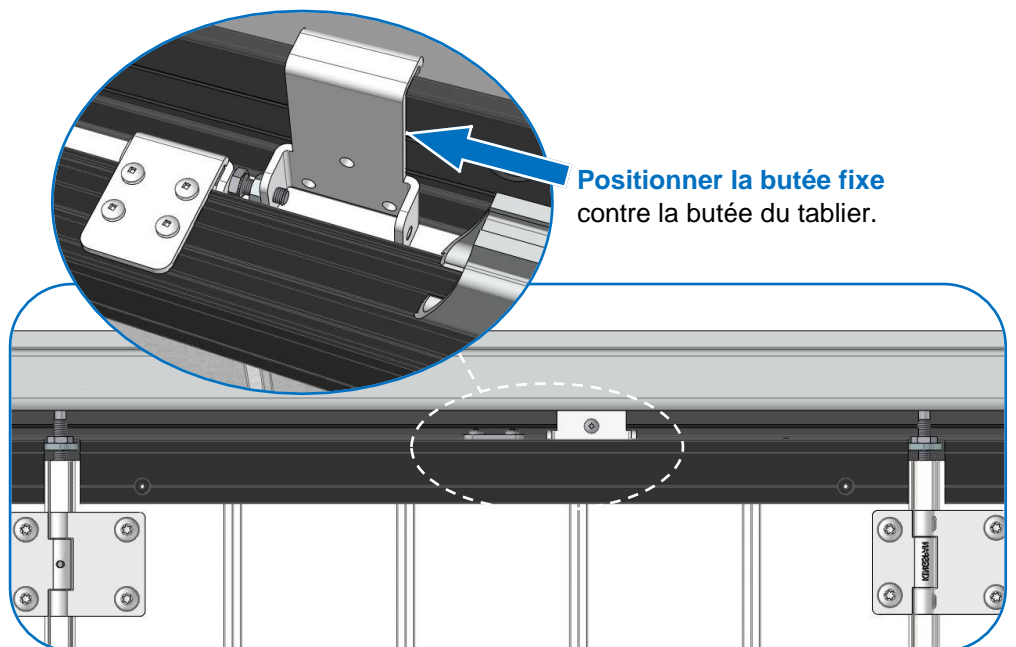
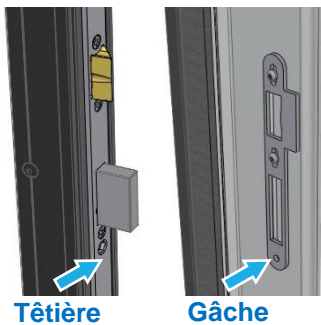

• Fixer la butée "Tablier" :

1- Fixer par 1 vis

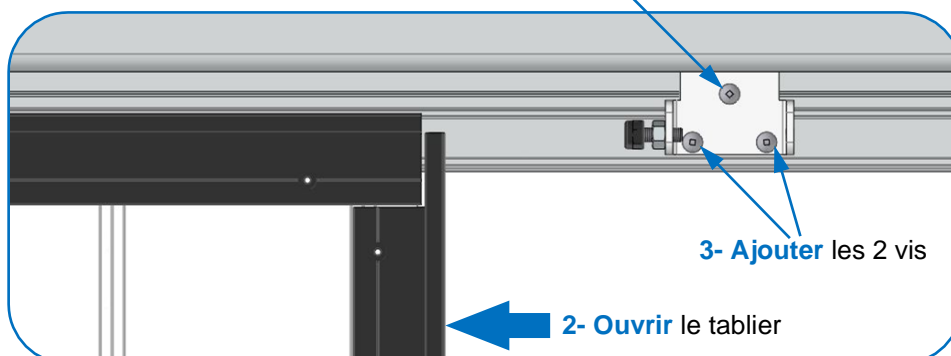

• **Vérifier le jeu "Portillon fermé" :**

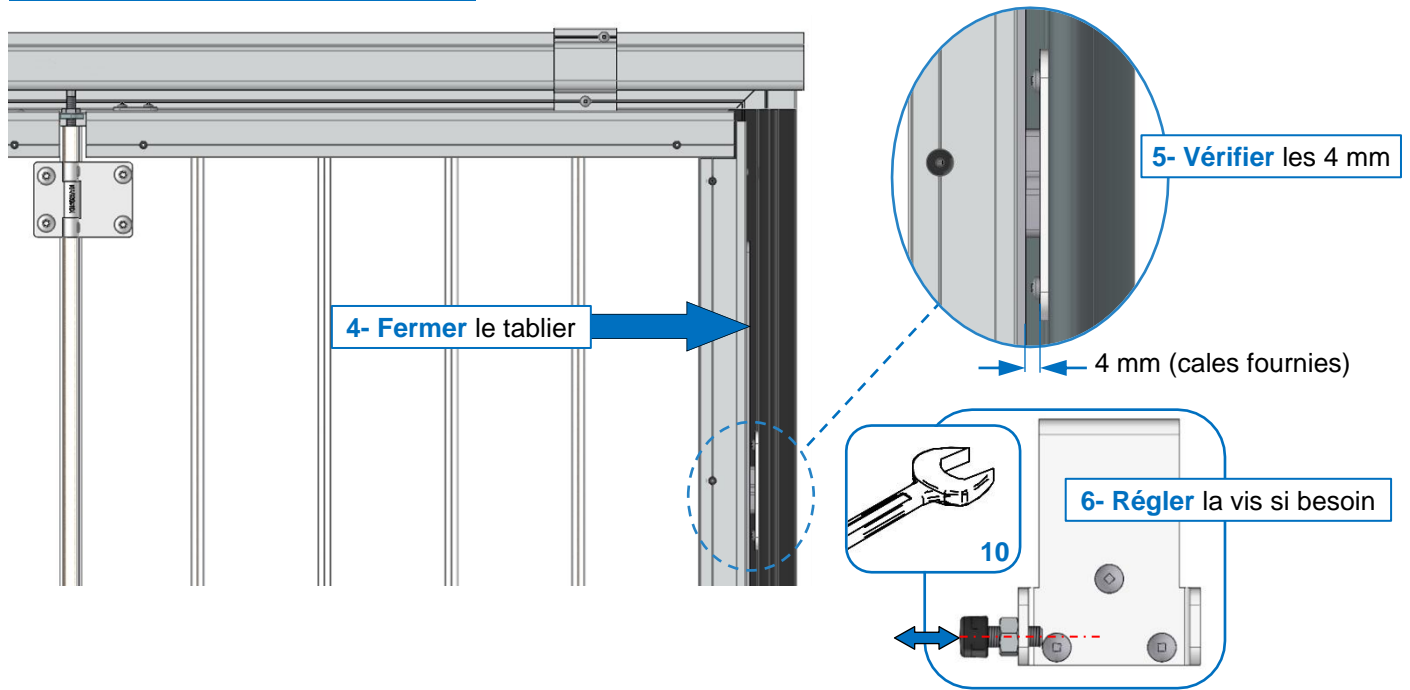

• **Préparation de la butée "Anti-retour" :**

Refoulement à gauche

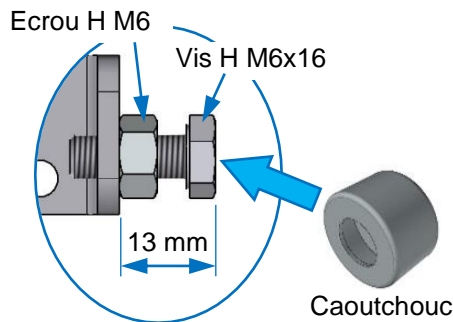
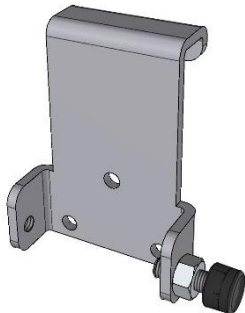

Refoulement à droite

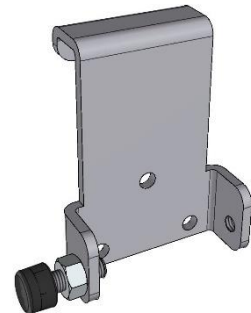

• **Installation de la butée "Anti-retour" :**

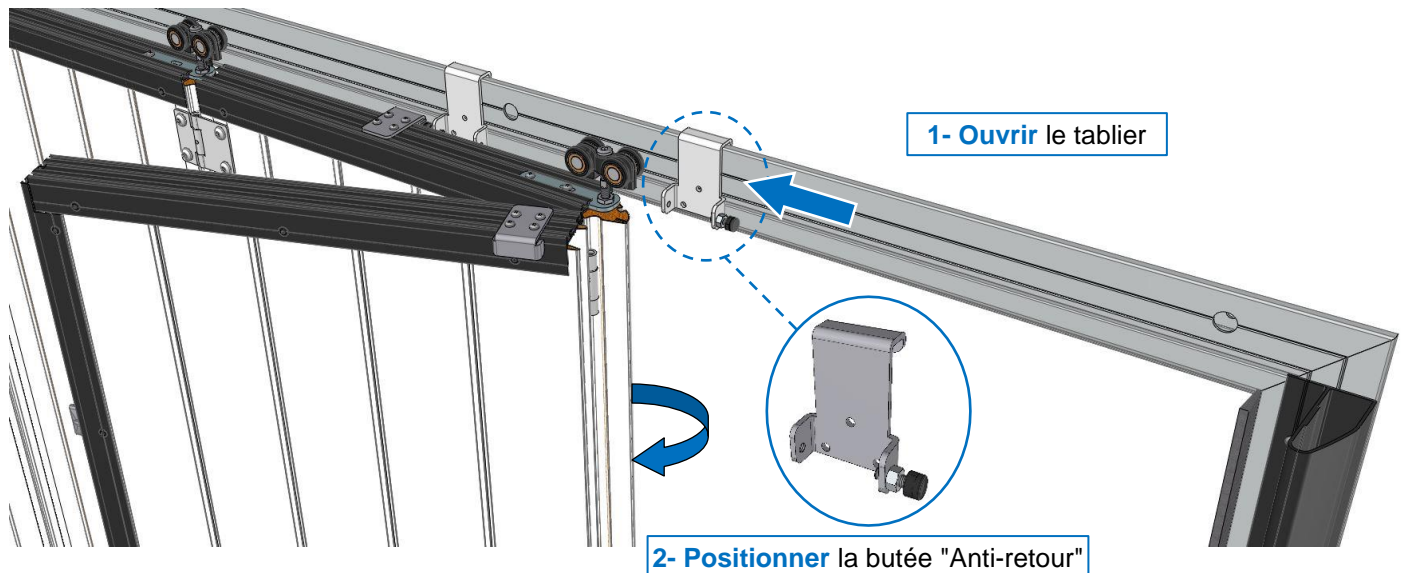

• **Fixer la butée "Anti-retour" :** 3- Fermer le portillon

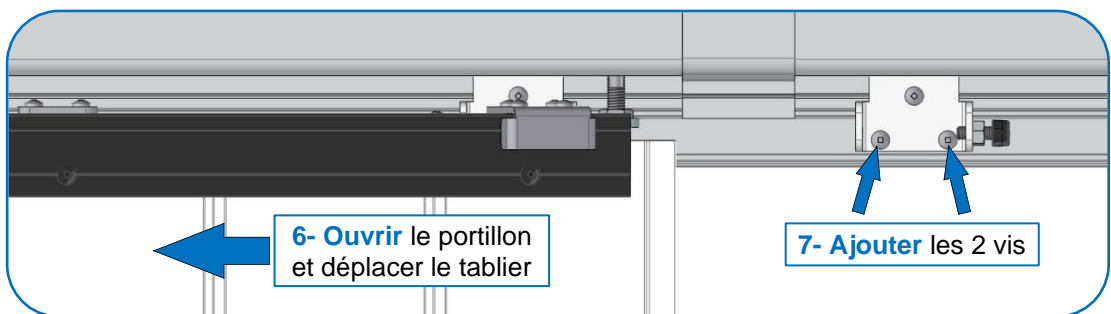
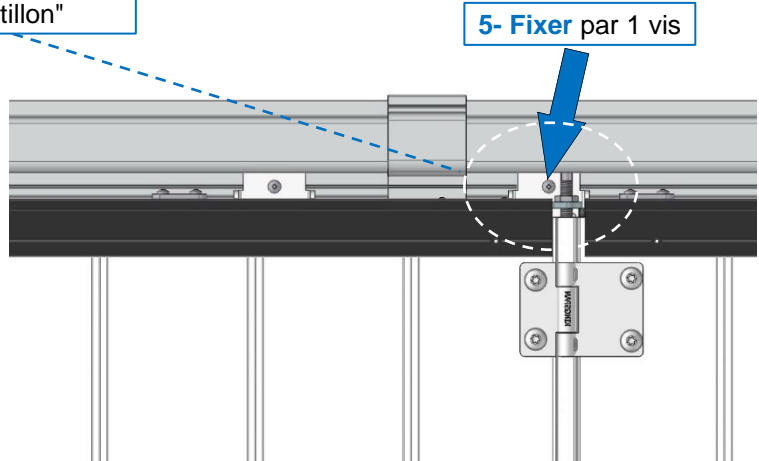
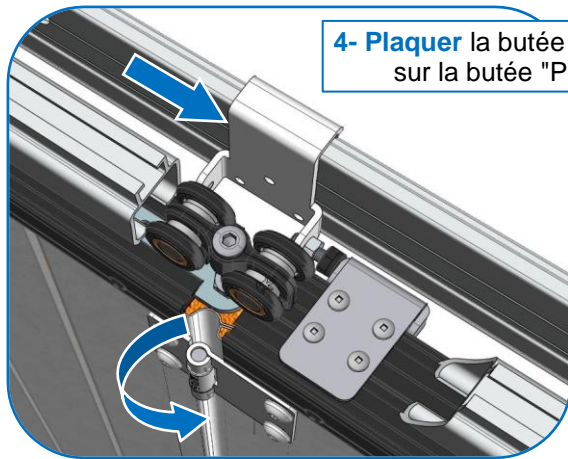

• **Régler la butée "Anti-retour" :**

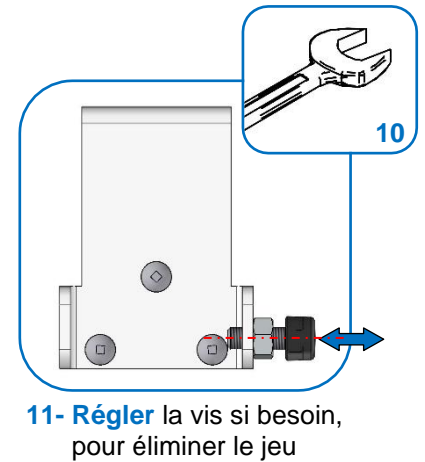
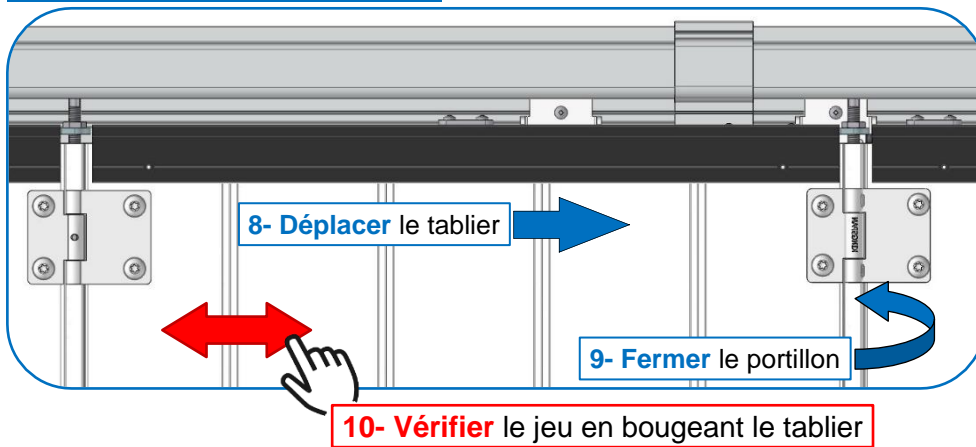

Réglage des patins



$300 \leq \text{ECR} \leq 550 \text{ mm}$

$550 < \text{ECR} \leq 1000 \text{ mm}$

$\text{ECR} > 1000 \text{ mm}$

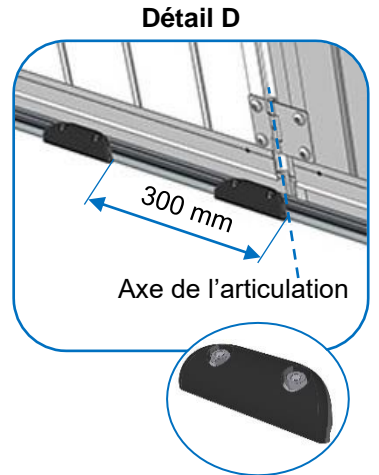
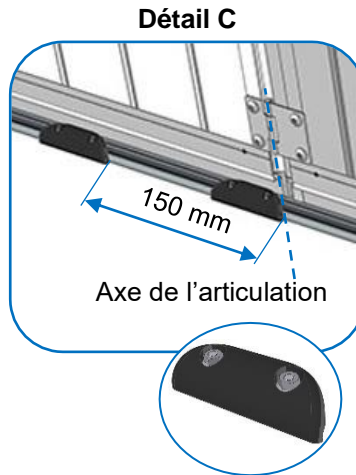
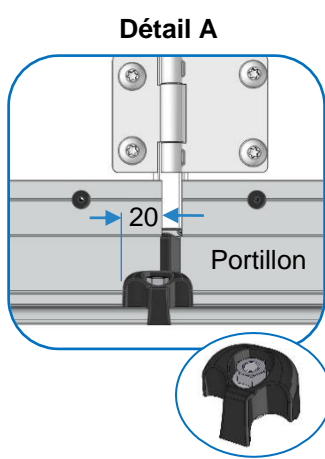
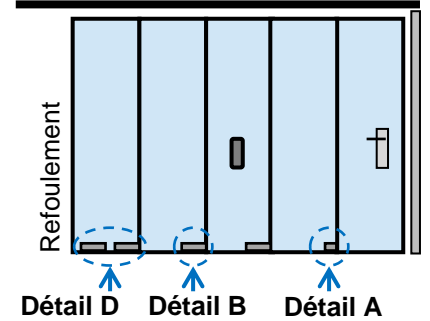
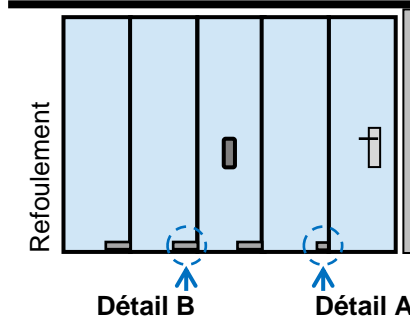
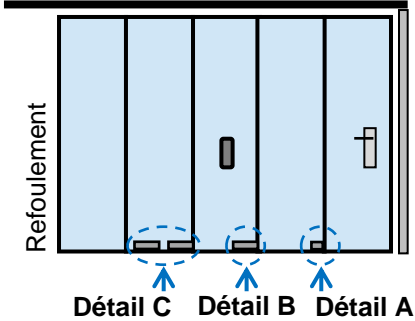

Fixer les supports de rail intermédiaires

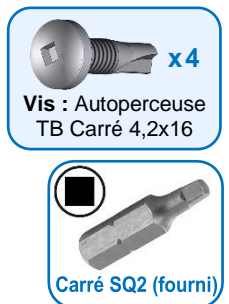
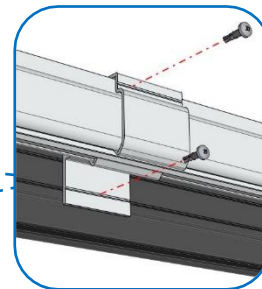
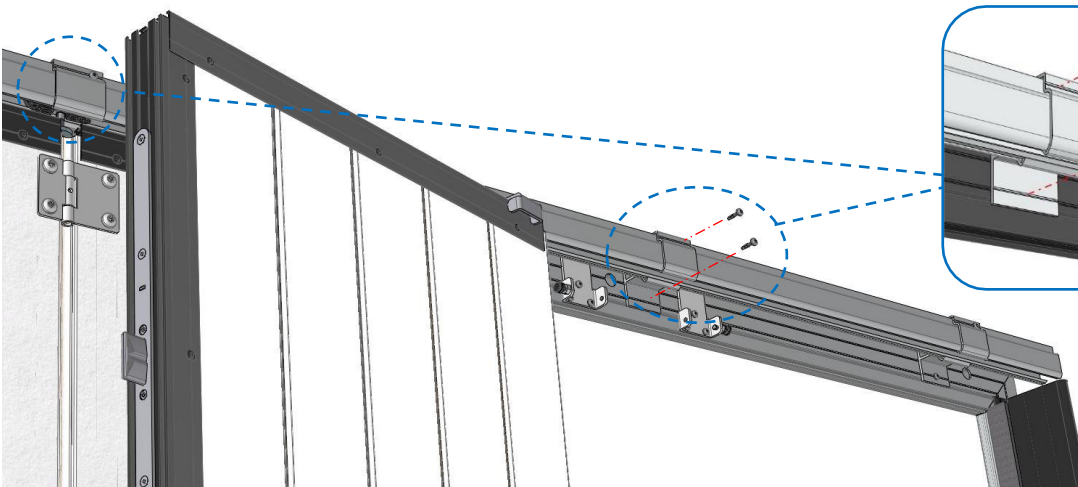

Montage du guidage

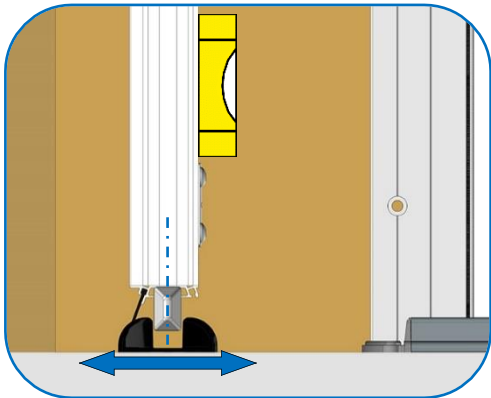
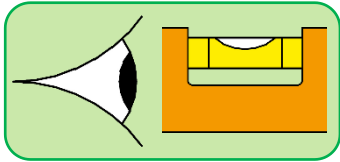

Porte en position ouverte, centrer le guide et le fixer (vis non fournies)

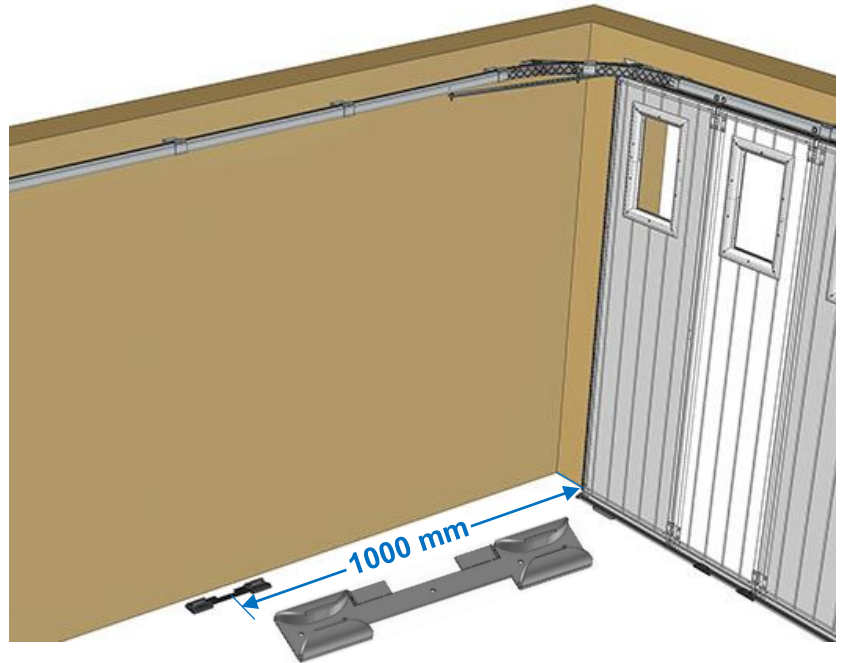

Système de placage du tablier (panneau côté refoulement)

IMPORTANT

Si $HP \leq 2500$ mm, alors 1 système de placage

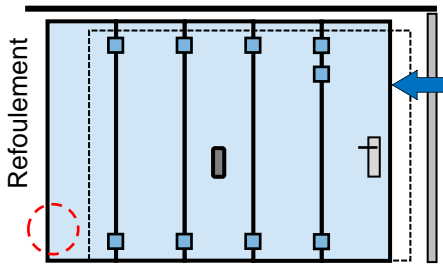

Si $HP > 2500$ mm, alors 2 systèmes de placage

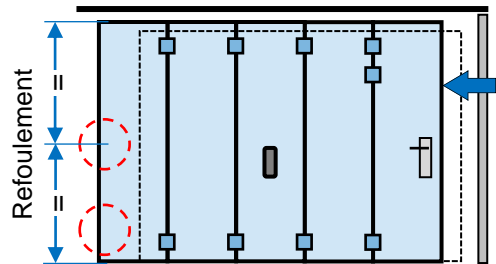

OU

• $300 \leq ECR < 600$ mm :

1 - Assembler la chape support

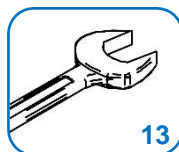
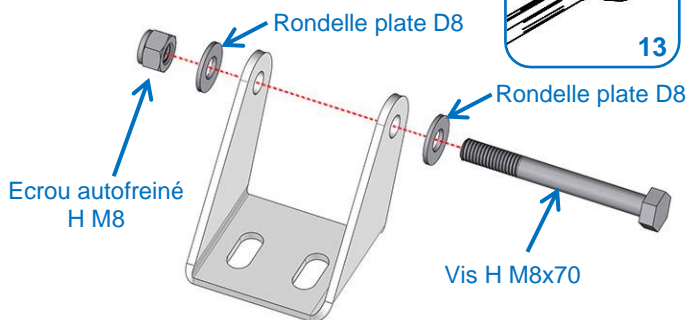

Visser sur les axes de trusquin

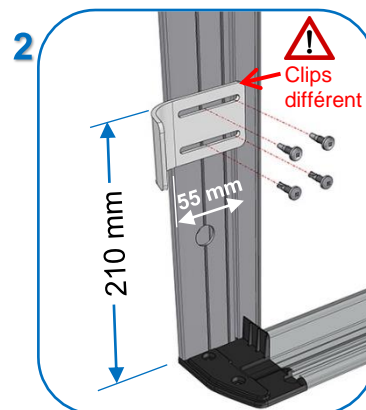

Clips différent en fonction de l'écoinçon

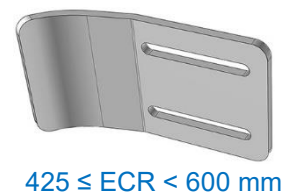
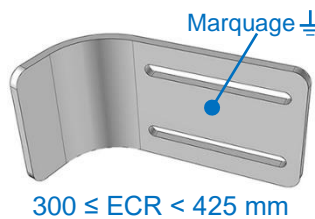

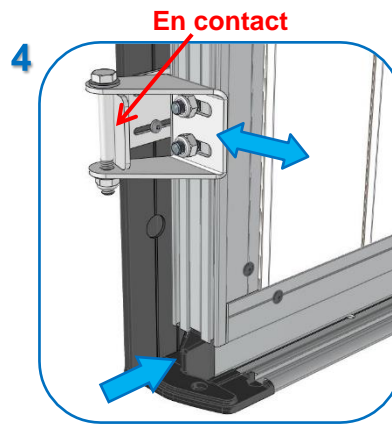
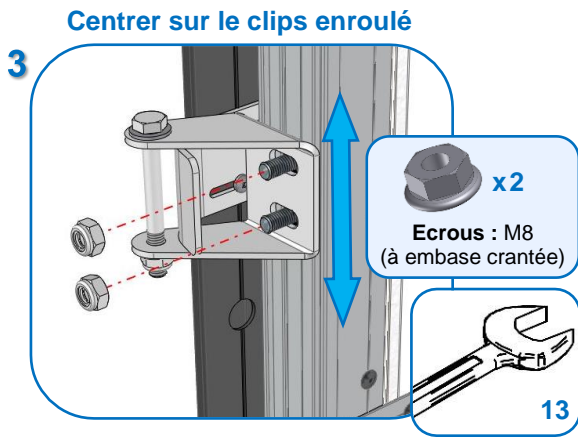

- A- Appuyer sur le bas du panneau
- B- Tirer la chape support
- C- Bloquer les écrous

• **ECR ≥ 600 mm :**

Visser sur l'axe de trusquin

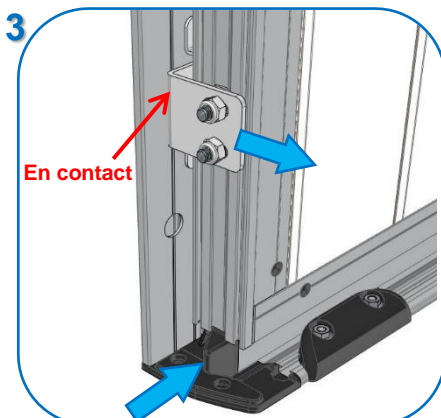
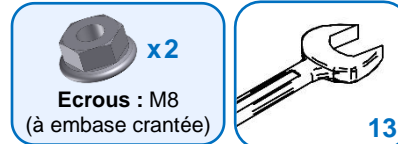
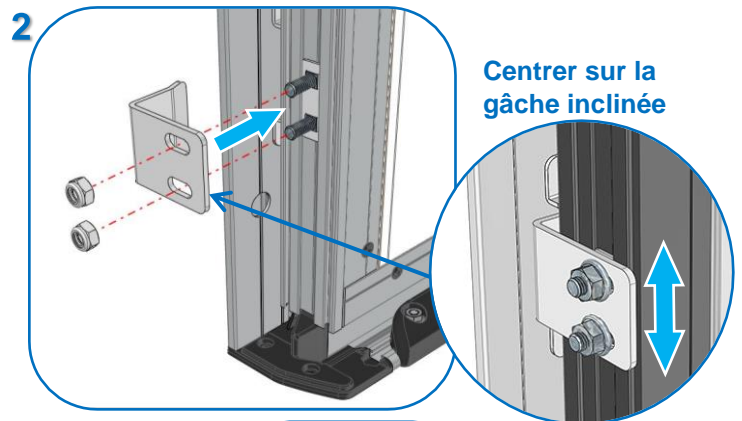
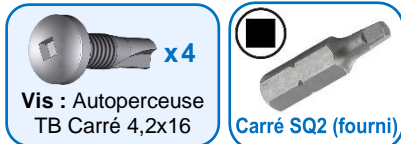
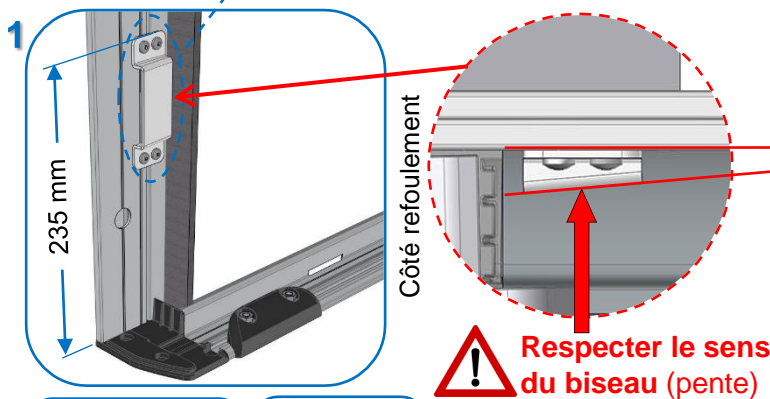

- 1- Appuyer sur le bas du panneau
- 2- Tirer le clips angulaire
- 3- Bloquer les écrous

Accessoires

Montage du verrou bas

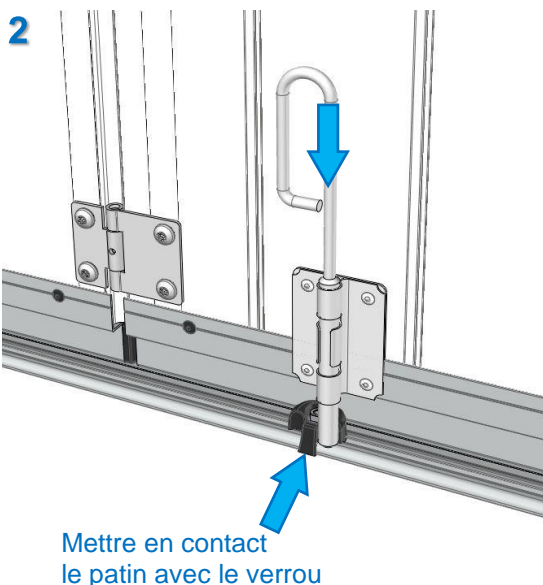
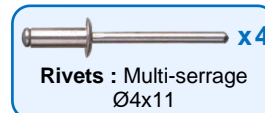
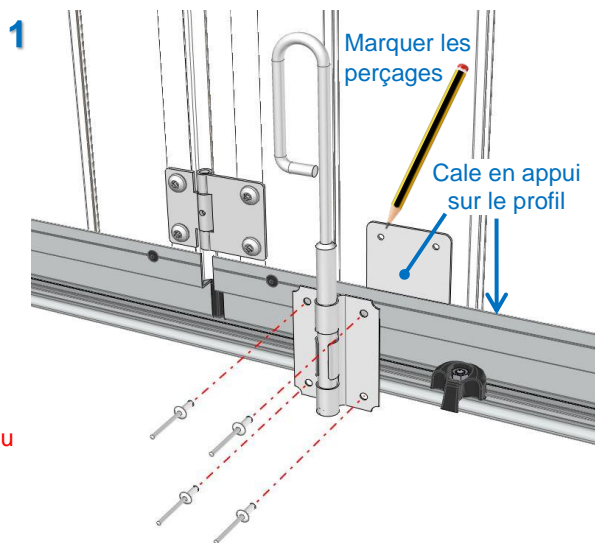
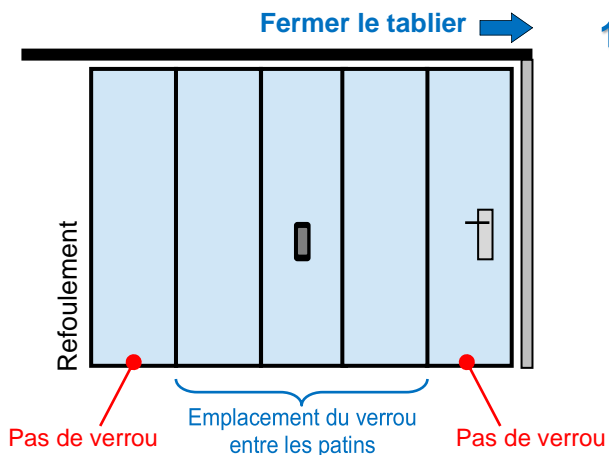

Ouvrir le verrou puis le tablier

3

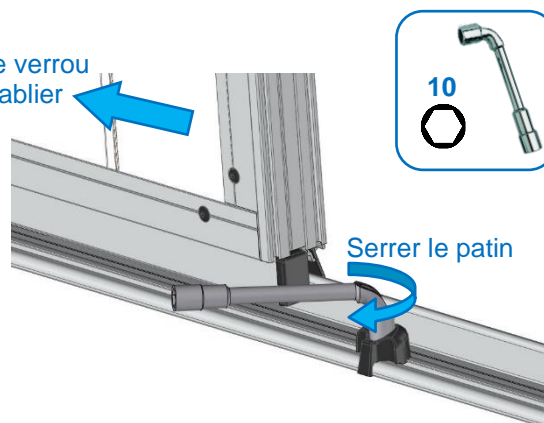

Montage de l'arrêt portillon

1 - Assembler le support



2 - Positionner l'ensemble support

Sur panneau intermédiaire de 500 mm

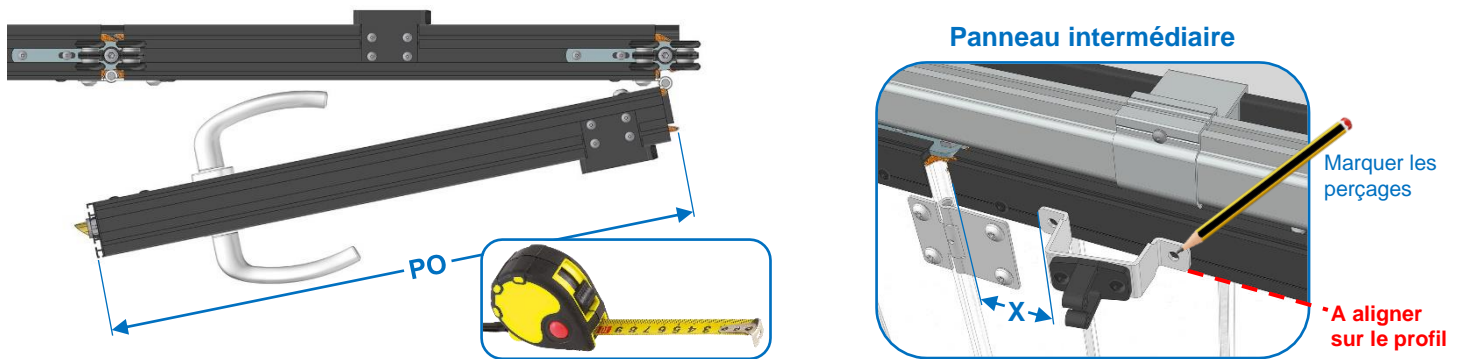

Longueur du Portillon (en mm)																							
PO	537	539	541	543	545	547	549	551	553	555	557	559	561	563	565	567	569	571	573	575	577	579	
Position de l'ensemble support (en mm)																							
X	65	64	63	62	61	60	59	58	57	56	55	54	53	52	51	50	49	48	47	46	45	44	

Sur panneau intermédiaire de 610 mm

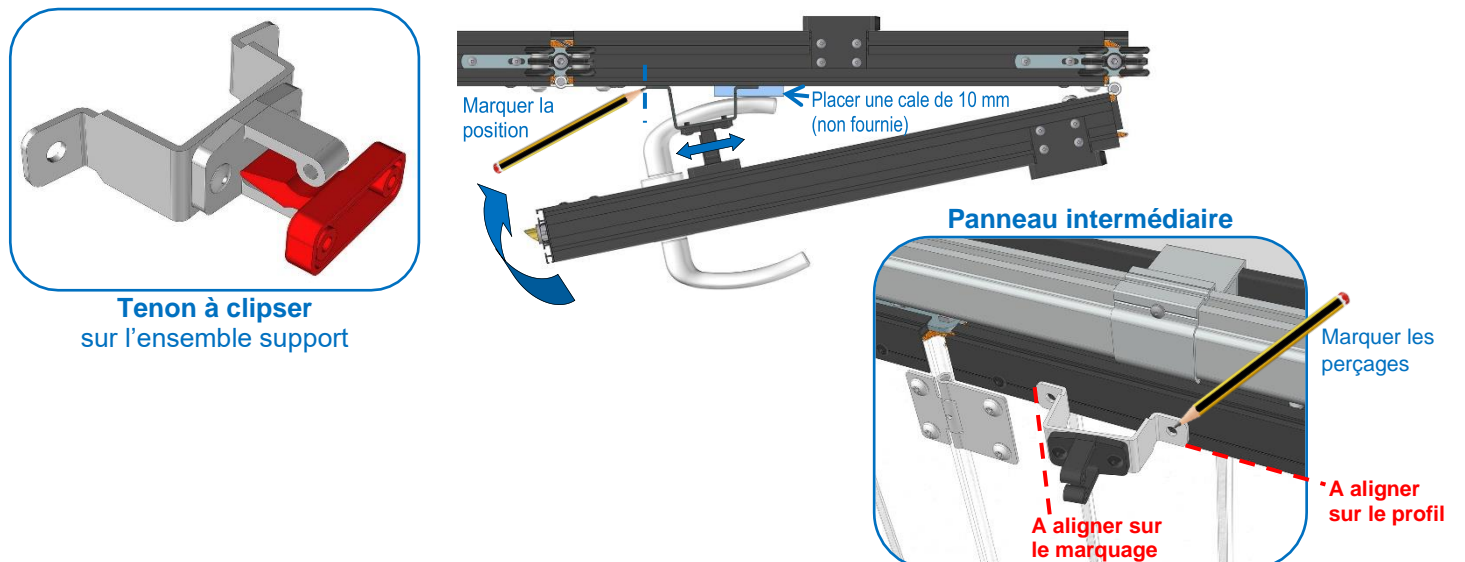

Sur panneau intermédiaire de 500 mm ou de 610 mm

3 - Fixer l'ensemble support

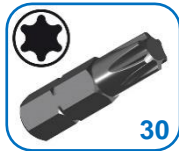
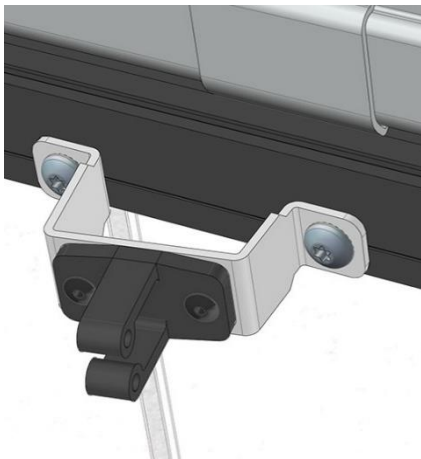

4 - Positionner le tenon

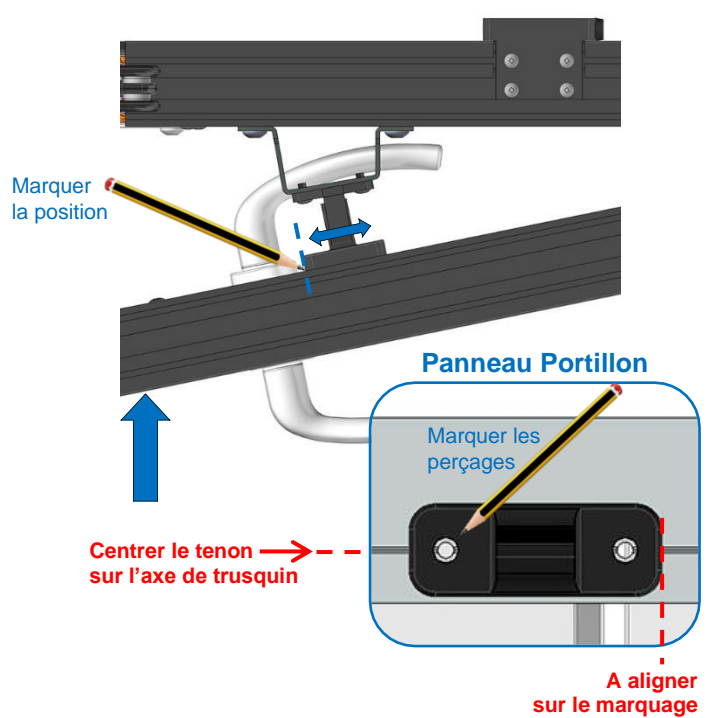

5 - Fixer le tenon

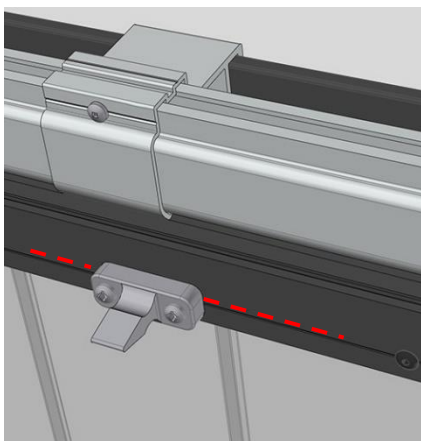

6 - Clipser le Portillon

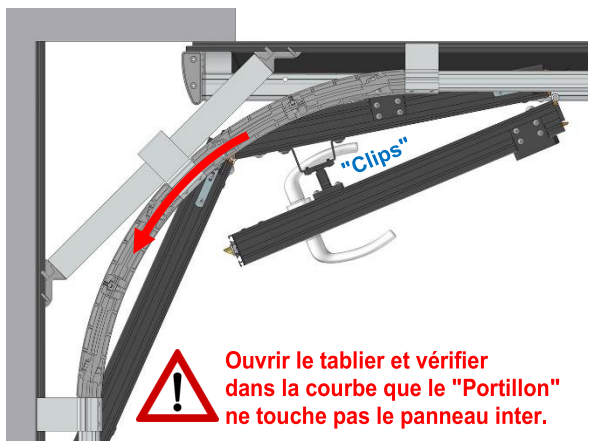

Option

Montage du verrou haut

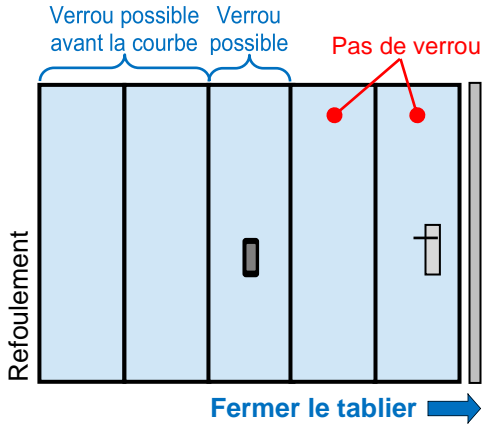

1 - Installer la cale

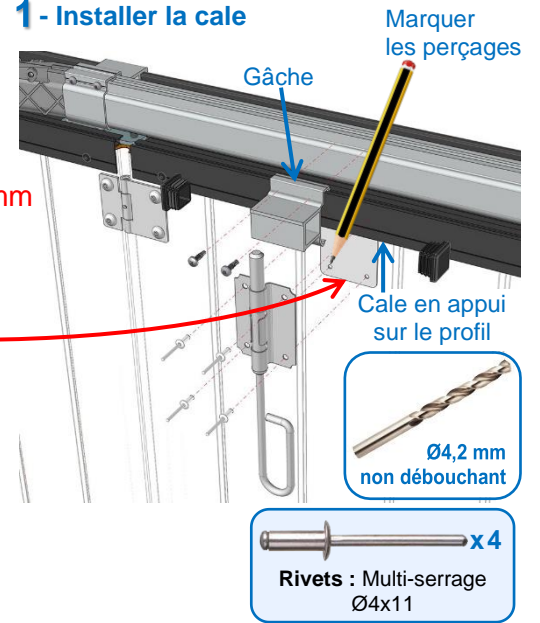

2 - Assembler la gâche et la clipser sur le rail

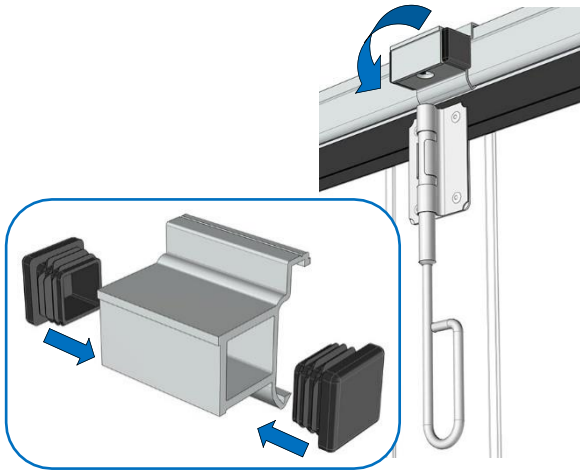

3 - Plaquer la gâche contre le verrou

